

NOTES

1. NON-IMPACT RESISTANT OPTION - .125" MINIMUM DSB GLAZING MEETS UNIFORM STATIC DESIGN PRESSURES SHOWN ON THIS DRAWING. GLAZING SHALL HAVE A MAXIMUM HEIGHT OF 6.70' AND A MAXIMUM LENGTH OF 24.00'. GLAZING IS NOT IMPACT RESISTANT AND DOES NOT MEET THE REQUIREMENTS FOR WIND-BORNE DEBRIS REGIONS.

2. IMPACT RESISTANT GLAZING OPTION - IMPACT RESISTANT GLAZING SYSTEM MAY BE INSTALLED IN INTERMEDIATE SECTIONS (WITH OR WITHOUT DECORATIVE INSERTS). GLAZING SHALL BE 1/4" POLYCARBONATE. MAXIMUM GLAZING DIMENSIONS SHALL BE 11" x 17", FASTENED WITH A MINIMUM #8 X 1" SMS; 3X ALONG THE HORIZONTAL AND 2X ALONG THE VERTICAL.

3. ALUMINUM FULL VIEW OPTION - ALUMINUM FULL VIEW SECTION MAY REPLACE ANY SECTION EXCEPT TOP AND BOTTOM PANELS. ALUMINUM FULL VIEW SECTION SHALL HAVE RAILS AND STILES OF EXTRUDED ALUMINUM ALLOY 6063-T6 AND .125" MINIMUM DSB GLAZING INSTALLED WITH ALUMINUM RETAINERS IN ORDER TO MEET UNIFORM STATIC DESIGN PRESSURES SHOWN ON THIS DRAWING. AFV PANEL SIZE IS 45.5"x21.9" (MAX). GLAZING IS NOT IMPACT RESISTANT AND DOES NOT MEET THE REQUIREMENTS FOR WIND-BORNE DEBRIS REGIONS.

4. MINIMUM OF 1" OVERLAP ON BOTH JAMBS REQUIRED TO MEET NEGATIVE DESIGN PRESSURES.

5. SLIDE LOCK OR OPERATOR REQUIRED.

6. SECTION STEEL TO HAVE THE FOLLOWING MINIMUM THICKNESS:
421, 423 - 20 GA
427, 429 - 24 GA
434, 436 - 25 GA

7. THE DESIGN OF THE SUPPORTING STRUCTURAL ELEMENTS SHALL BE THE RESPONSIBILITY OF THE PROFESSIONAL OF RECORD FOR THE BUILDING OR STRUCTURE AND IN ACCORDANCE WITH CURRENT BUILDING CODES FOR THE LOADS LISTED ON THIS DRAWING.

8. TRACK CLIPS SHALL BE LOCATED WITH CENTERLINE OF BOTTOM CLIP SPACED 10" MAX FROM BOTTOM OF TRACK AND REMAINING TRACK CLIPS SPACED AT 24" O.C. MAX. SPACING BETWEEN TOP TRACK CLIP AND SPLICE PLATE SHALL BE 30" O.C. MAX.

9. WHEN MOUNTING TO WOOD, DOOR JAMB TO BE MINIMUM 2x6 STRUCTURAL GRADE LUMBER. REFER TO JAMB CONNECTION SUPPLEMENT FOR ATTACHMENT TO SUPPORTING STRUCTURE.

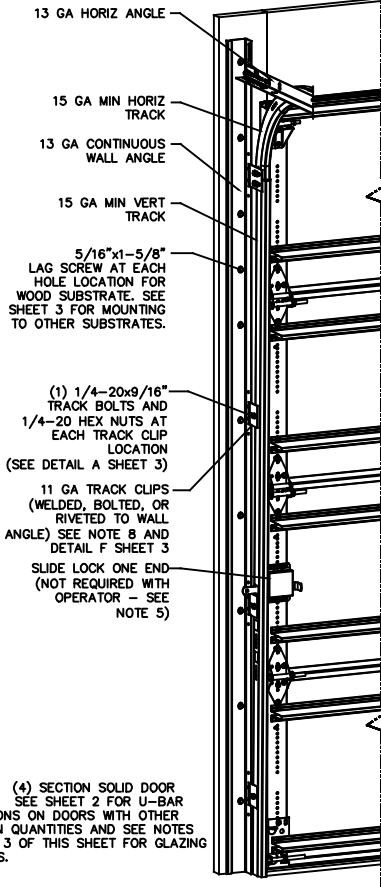

NOTE: (4) SECTION SOLID DOOR SHOWN. SEE SHEET 2 FOR U-BAR LOCATIONS ON DOORS WITH OTHER SECTION QUANTITIES AND SEE NOTES 1, 2 & 3 OF THIS SHEET FOR GLAZING OPTIONS.

SUPERIMPOSED DESIGN PRESSURE LOADS ON SUPPORTING STRUCTURE

MAX DOOR WIDTH	DOOR HEIGHT	MAX UNIFORM LOAD EACH JAMB (PLF)
9'-4"	ALL	+204.6/-231.6

STATIC PRESSURE RATINGS	APPROVED SIZES
DESIGN PRESSURE (PSF): +44.0/-49.8	MAX WIDTH: 9'-4" MAX HEIGHT: 24'-1"
IMPACT/CYCLIC RATED: YES	MAX SECTION HEIGHT: 24'

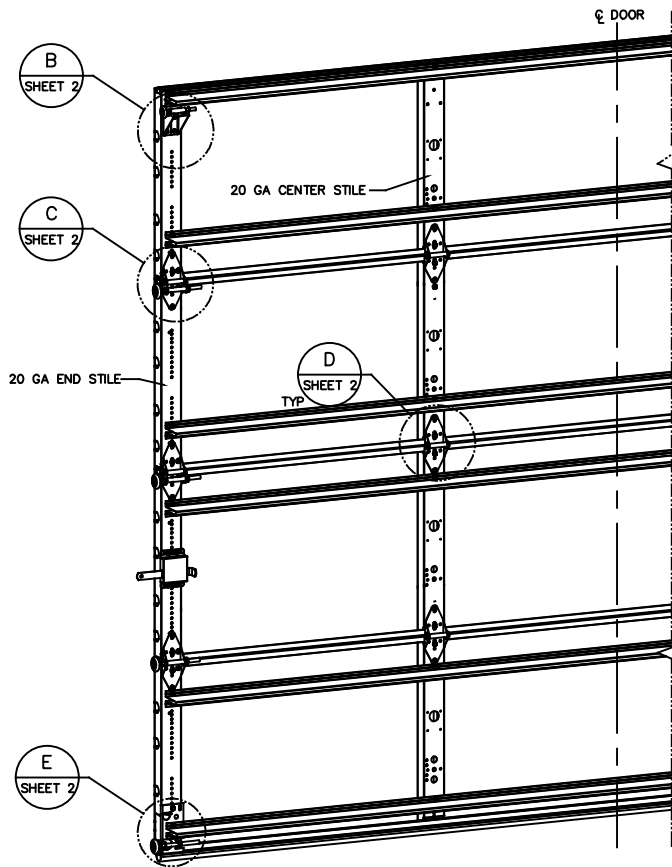
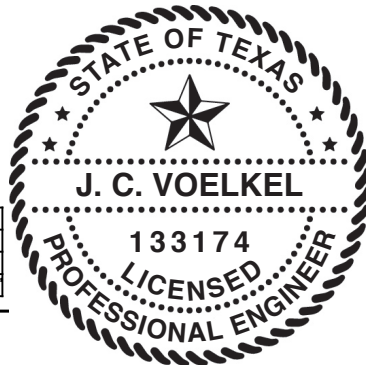

REVISIONS				
OR	REV	DESCRIPTION	DATE	APPROVAL
VL005	-	INITIAL DRAWING	1/13/2021	TLC
VL005	A	ADDED AFV PANEL SIZE	4/27/21	TLC

THE DOORS ARE DESIGNED AND MANUFACTURED TO COMPLY WITH THE 2018 IRC AND THE 2018 IBC.

THE DRAWINGS AND ALL OTHER INFORMATION CONTAINED HEREIN ARE THE CONFIDENTIAL AND PROPRIETARY PROPERTY OF OVERHEAD DOOR CORPORATION AND ITS AFFILIATED COMPANIES. THIS DRAWING AND INFORMATION, IN WHOLE OR IN PART, MAY NOT BE COPIED IN ANY MANNER OR DISCLOSED TO ANYONE WITHOUT THE PRIOR WRITTEN CONSENT OF OVERHEAD DOOR CORPORATION. NO DISCLOSURE OF ANY OF THIS DRAWING OR INFORMATION IS INTENDED TO OPERATE AS A LICENSE OR AUTHORIZATION TO USE IT FOR ANY PURPOSE WITHOUT THE SPECIFIC WRITTEN CONSENT OF OVERHEAD DOOR CORPORATION.										
REF DWG	USED ON	 WELDING SYMBOLS AND THEIR MEANINGS AS PER THE AISC STANDARD FOR STRUCTURAL STEEL CONNECTIONS AND RELATED JOINTS, 4th EDITION, 2013.	TOLERANCES UNLESS OTHERWISE SPECIFIED		FINISH N/A	The Genuine. The Original. LEVELL LEVELVILLE, TEXAS	NAME T CLARK	DATE 8/12/2020	DRAWING TITLE VINYL DOOR OPTION CODE 2066 SERIES 421/423/427/429/434/436, 44.0/-49.8 PSF, 9'-4" MAX	
			HOLE DIAMETER UNDER .251 +.004/- .003 .251 TO .500 +.006/- .003 OVER .500 +.008/- .003	WHOLE NUMBERS: ± .25 FRACTIONS: ± .010 ANGLES: ± .5°						UNIT OF MEASURE EA
			± 1/16				APPROVED BY T CLARK	DATE 4/27/21	SCALE N/A	SHEET 1 OF 3

1/4-20x9/16" TRACK BOLT AND 1/4-20 HEX NUT THROUGH THE SLOT IN THE TRACK AND TRACK CLIP



DETAIL A

12 GA COMMERCIAL TOP FRAME BRACKET WITH 13 GA ROLLER CARRIER ATTACHED WITH (4) 1/4-14x7/8" SELF DRILLING CRIMPITITE SCREWS

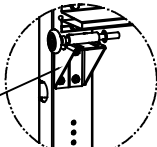

DETAIL B

ADD (2) 1/4-14x7/8" SELF DRILLING CRIMPITITE SCREWS (INSIDE OF EACH INSIDE END HINGE)

2" STEEL ROLLER WITH 5-1/8" STEM AND 7/16" PUSHNUT AT EACH ROLLER LOCATION. 1/4" MAX BETWEEN PUSHNUT AND BRACKET OR HINGE

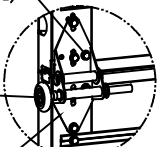

DETAIL C

14 GA WIDE BODY END HINGE TO ATTACH SECTIONS ONE AND TWO. 13 GA WIDE BODY END HINGE TO ATTACH REMAINING SECTIONS. FOR ALL, ATTACH WITH (4) 1/4-14x7/8" SELF DRILLING CRIMPITITE SCREWS

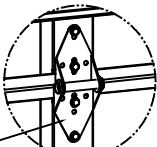

SOLID SECTION

14 GA WIDE BODY INTERMEDIATE HINGE ATTACHED WITH (4) 1/4-14x7/8" SELF DRILLING CRIMPITITE SCREWS

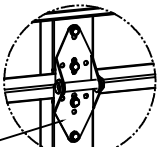

(2) 1/4-14x7/8" SELF DRILLING CRIMPITITE SCREWS
HALF HINGE
(2) 1/4 x 1/2" CARRIAGE BOLTS AND 1/4" FLANGE NUTS

AFV SECTION

12 GA BOTTOM BRACKET ATTACHED WITH (3) 1/4-14x7/8" SELF DRILLING CRIMPITITE SCREWS

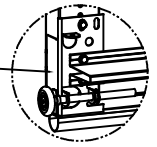

DETAIL E

DETAIL D

ATTACH U-BARS WITH (2) 1/4-14x7/8" SELF DRILLING CRIMPITITE SCREWS AT ALL STILE LOCATIONS, TYP.

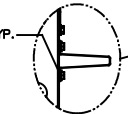

(4) SECTION DOORS WITH (6) 3" 18 GA 80 KSI U-BARS LOCATED AS SHOWN

(5) SECTION DOORS WITH (8) 3" 18 GA 80 KSI U-BARS LOCATED AS SHOWN

(6) SECTION DOORS WITH (9) 3" 18 GA 80 KSI U-BARS LOCATED AS SHOWN

(7) SECTION DOORS WITH (11) 3" 18 GA 80 KSI U-BARS LOCATED AS SHOWN

(8) SECTION DOORS WITH (12) 3" 18 GA 80 KSI U-BARS LOCATED AS SHOWN

(9) SECTION DOORS WITH (14) 3" 18 GA 80 KSI U-BARS LOCATED AS SHOWN

(10) SECTION DOORS WITH (15) 3" 18 GA 80 KSI U-BARS LOCATED AS SHOWN

(11) SECTION DOORS WITH (17) 3" 18 GA 80 KSI U-BARS LOCATED AS SHOWN

(12) SECTION DOORS WITH (18) 3" 18 GA 80 KSI U-BARS LOCATED AS SHOWN

STATIC PRESSURE RATINGS	APPROVED SIZES
DESIGN PRESSURE(PSF): +44.0/-49.8	MAX WIDTH: 9'-4" MAX HEIGHT: 24'-1"
IMPACT/CYCLIC RATED: YES	MAX SECTION HEIGHT: 24'

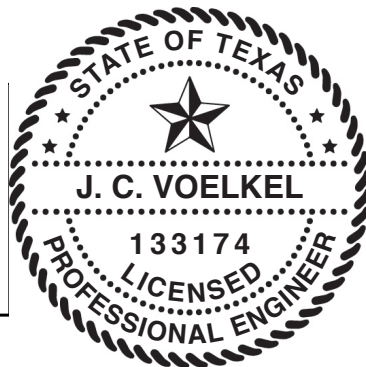

THE DRAWINGS AND ALL OTHER INFORMATION CONTAINED HEREIN ARE THE CONFIDENTIAL AND PROPRIETARY PROPERTY OF OVERHEAD DOOR CORPORATION AND ITS AFFILIATED COMPANIES. THIS DRAWING AND INFORMATION, IN WHOLE OR IN PART, MAY NOT BE COPIED IN ANY MANNER OR DISCLOSED TO ANYONE WITHOUT THE PRIOR WRITTEN CONSENT OF OVERHEAD DOOR CORPORATION. NO DISCLOSURE OF ANY OF THIS DRAWING OR INFORMATION IS INTENDED TO OPERATE AS A LICENSE OR AUTHORIZATION TO USE IT FOR ANY PURPOSE WITHOUT THE SPECIFIC WRITTEN CONSENT OF OVERHEAD DOOR CORPORATION.			
	TOLERANCES UNLESS OTHERWISE SPECIFIED HOLE DIAMETER UNDER .251 +.004/- .003 .251 TO .500 +.006/- .003 OVER .500 +.008/- .003	FINISH N/A	DATE 9/12/2020
	WHOLE NUMBERS: ± .25 .X ± .1 .XX ± .03 .XXX ± .010 ANGLES: ± .5°	UNIT OF MEASURE EA	MATERIAL N/A
REF DWG	USED ON	CHECKED BY T CLARK	DRAWING NUMBER D- 411782
		APPROVED BY T CLARK	SHEET 2 OF 3

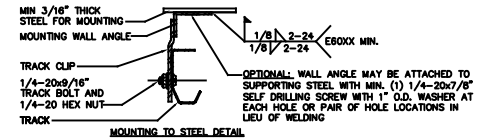
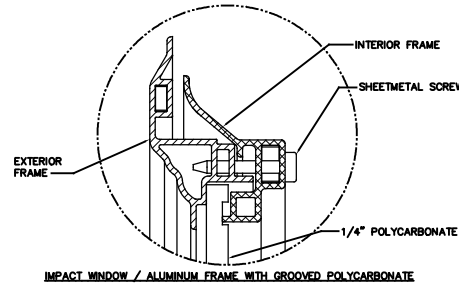
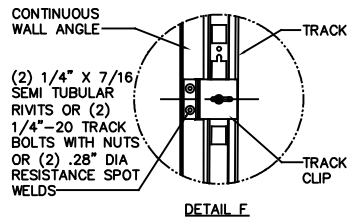
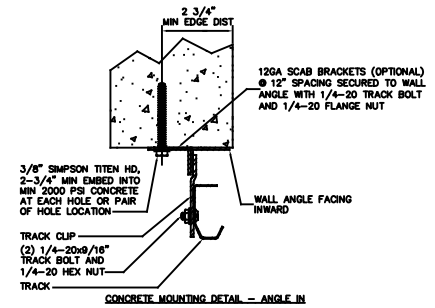
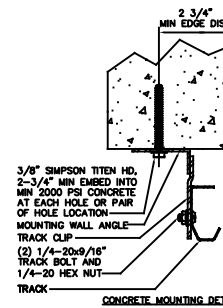
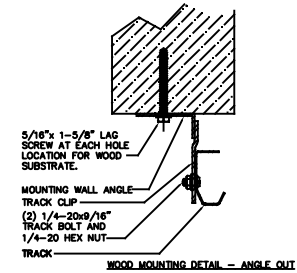
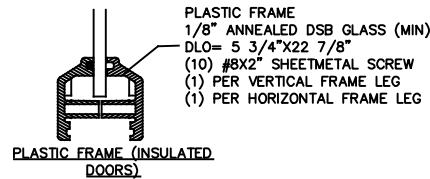
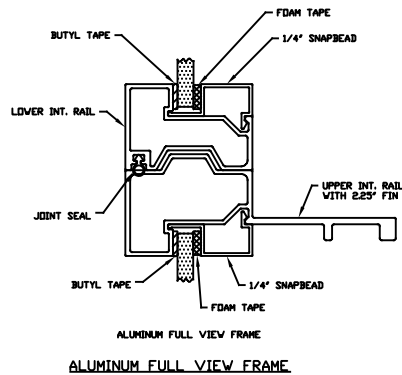
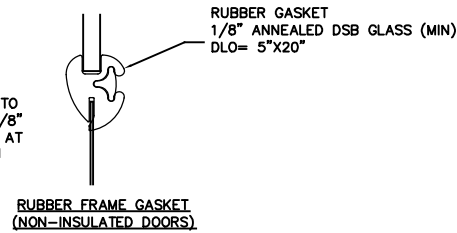
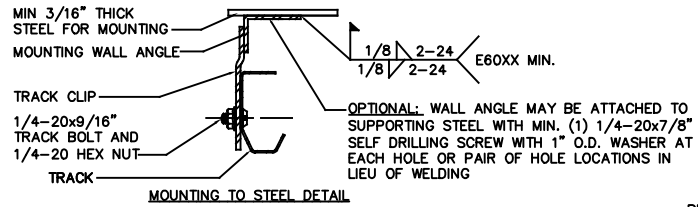

STATIC PRESSURE RATINGS	APPROVED SIZES
DESIGN PRESSURE(PSF): +44.0/-49.8	MAX WIDTH: 9'-4" MAX HEIGHT: 24'-1"
IMPACT/CYCLIC RATED: YES	MAX SECTION HEIGHT: 24'

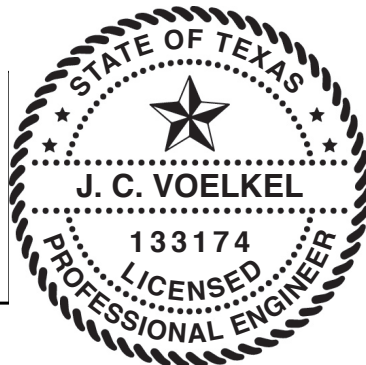

THE DRAWINGS AND ALL OTHER INFORMATION CONTAINED HEREIN ARE THE CONFIDENTIAL AND PROPRIETARY PROPERTY OF OVERHEAD DOOR CORPORATION AND ITS AFFILIATED COMPANIES. THIS DRAWING AND INFORMATION, IN WHOLE OR IN PART, MAY NOT BE COPIED IN ANY MANNER OR DISCLOSED TO ANYONE WITHOUT THE PRIOR WRITTEN CONSENT OF OVERHEAD DOOR CORPORATION. NO DISCLOSURE OF ANY OF THIS DRAWING OR INFORMATION IS INTENDED TO OPERATE AS A LICENSE OR AUTHORIZATION TO USE IT FOR ANY PURPOSE WITHOUT THE SPECIFIC WRITTEN CONSENT OF OVERHEAD DOOR CORPORATION.																																															
<table border="1"> <tr> <th>TOLERANCES UNLESS OTHERWISE SPECIFIED</th> <th>FINISH</th> </tr> <tr> <td>HOLE DIAMETER</td> <td>N/A</td> </tr> <tr> <td>UNDER .251 +.004/-003</td> <td></td> </tr> <tr> <td>.251 TO .500 +.006/-003</td> <td></td> </tr> <tr> <td>OVER .500 +.008/-003</td> <td></td> </tr> <tr> <td>FRACTIONS</td> <td></td> </tr> <tr> <td>± 1/16</td> <td></td> </tr> </table>	TOLERANCES UNLESS OTHERWISE SPECIFIED	FINISH	HOLE DIAMETER	N/A	UNDER .251 +.004/-003		.251 TO .500 +.006/-003		OVER .500 +.008/-003		FRACTIONS		± 1/16		<table border="1"> <tr> <th>WHOLE NUMBERS</th> <th>UNIT OF MEASURE</th> </tr> <tr> <td>± .25</td> <td>EA</td> </tr> <tr> <td>± .1</td> <td></td> </tr> <tr> <td>± .03</td> <td></td> </tr> <tr> <td>± .010</td> <td></td> </tr> <tr> <td>± .5°</td> <td></td> </tr> </table>	WHOLE NUMBERS	UNIT OF MEASURE	± .25	EA	± .1		± .03		± .010		± .5°		<table border="1"> <tr> <th>DATE</th> <th>BY</th> <th>CHKD BY</th> <th>APP'D BY</th> </tr> <tr> <td>9/12/2020</td> <td>T CLARK</td> <td>J QIAN</td> <td>T CLARK</td> </tr> </table>	DATE	BY	CHKD BY	APP'D BY	9/12/2020	T CLARK	J QIAN	T CLARK	<table border="1"> <tr> <th>DRAWING TITLE</th> <th>DATE</th> </tr> <tr> <td>JINDL/DAD/OPTION CODE 2066 SERIES 421/423/427/429/434/436, 44.0/-49.8 PSF, 9'-4" MAX</td> <td>1/21/21</td> </tr> <tr> <td>DRAWING NUMBER</td> <td>SHEET</td> </tr> <tr> <td>D-411782</td> <td>N/A</td> </tr> <tr> <td></td> <td>3 OF 3</td> </tr> </table>	DRAWING TITLE	DATE	JINDL/DAD/OPTION CODE 2066 SERIES 421/423/427/429/434/436, 44.0/-49.8 PSF, 9'-4" MAX	1/21/21	DRAWING NUMBER	SHEET	D-411782	N/A		3 OF 3
TOLERANCES UNLESS OTHERWISE SPECIFIED	FINISH																																														
HOLE DIAMETER	N/A																																														
UNDER .251 +.004/-003																																															
.251 TO .500 +.006/-003																																															
OVER .500 +.008/-003																																															
FRACTIONS																																															
± 1/16																																															
WHOLE NUMBERS	UNIT OF MEASURE																																														
± .25	EA																																														
± .1																																															
± .03																																															
± .010																																															
± .5°																																															
DATE	BY	CHKD BY	APP'D BY																																												
9/12/2020	T CLARK	J QIAN	T CLARK																																												
DRAWING TITLE	DATE																																														
JINDL/DAD/OPTION CODE 2066 SERIES 421/423/427/429/434/436, 44.0/-49.8 PSF, 9'-4" MAX	1/21/21																																														
DRAWING NUMBER	SHEET																																														
D-411782	N/A																																														
	3 OF 3																																														