

Door Width 16' - 2" Shown
See chart below for other door widths

NOTE: Track configuration above the door opening does not affect the wind load rating of the door.

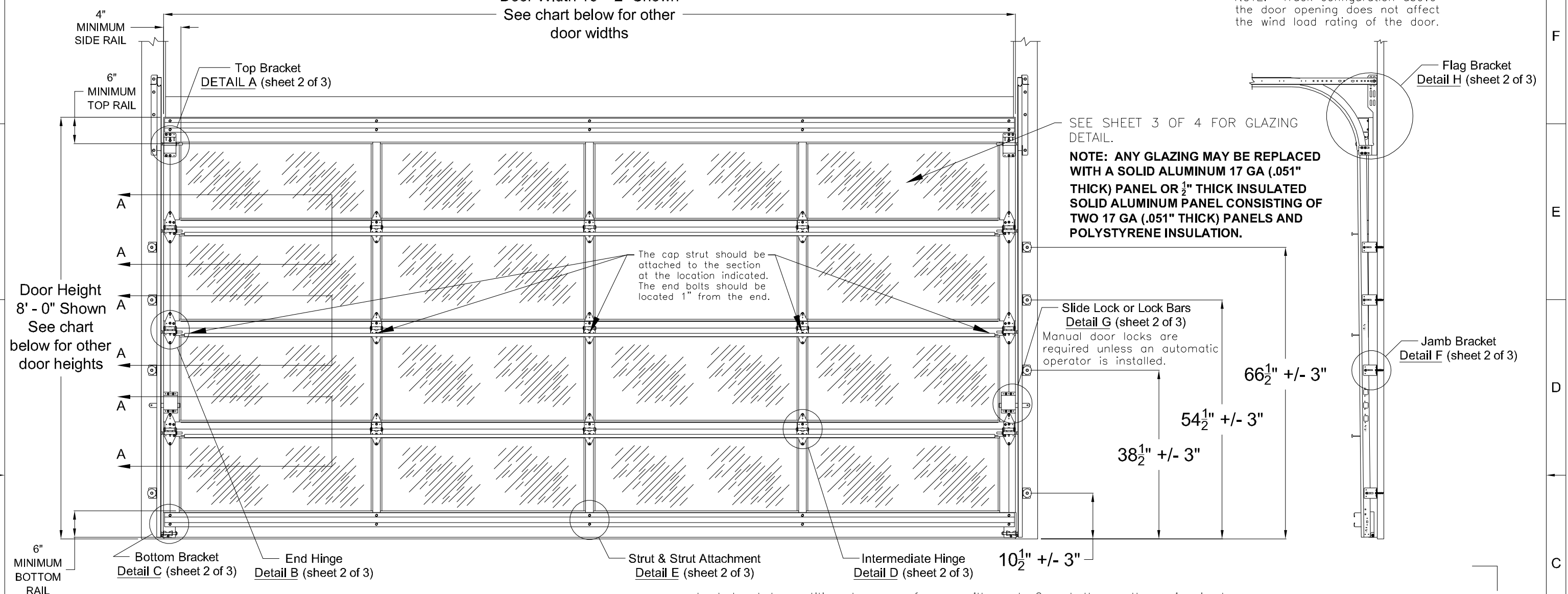

The cap strut should be attached to the section at the location indicated. The end bolts should be located 1" from the end.

SEE SHEET 3 OF 4 FOR GLAZING DETAIL.

NOTE: ANY GLAZING MAY BE REPLACED WITH A SOLID ALUMINUM 17 GA (.051" THICK) PANEL OR 1/2" THICK INSULATED SOLID ALUMINUM PANEL CONSISTING OF TWO 17 GA (.051" THICK) PANELS AND POLYSTYRENE INSULATION.

Slide Lock or Lock Bars Detail G (sheet 2 of 3)
Manual door locks are required unless an automatic operator is installed.

This product has been evaluated per ANSI/DASMA 108 for static air pressure.

Jamb bracket quantities shown are for use with grade 2 or better southern pine jambs.
Supporting structural elements are to be designed by a registered professional engineer for specific wind loads.

Door Widths Up To	Design Pressures		End Stile	Model Number			
	+ psf	- psf		RA 360 SERIES RA 360i SERIES		CA 320 SERIES CA 320i SERIES	
	Minimum Center Stiles	Minimum Center Hinges		Minimum Center Stiles	Minimum Center Hinges		
12'-2"	28.9	-32.2	Single	2	2	3	3
14'-2"	24.8	-27.7	Single	3	3	3	3
16'-2"	21.8	-24.3	Single	3	3	4	4

Door Height	Total # of Sections	Total # of Struts		Jamb Brkts per Side
		E Strut	Cap Strut	
6'-0"	3	2	2	3
6'-0"	4	2	3	3
6'-3"	4	2	3	3
6'-6"	4	2	3	4
6'-9"	4	2	3	4
7'-0"	4	2	3	4
7'-3"	4	2	3	4
7'-6"	4	2	3	4
7'-6"	5	2	4	4
7'-9"	4	2	3	4
7'-9"	5	2	4	4
8'-0"	4	2	3	4
8'-0"	5	2	4	4

NOTICE: These drawings are a supplement to the installation instructions for a standard door and only covers those procedures that vary from standard door installation. If these specific procedures are not followed, the door may not perform as designed.

This product is designed and sold by PSF. The AHJ or Engineer of Record is responsible for determining the PSF required for any given site.

NOTE: All "RA" Series have 6" End Stiles and 6" Top and Bottom Rails.

Maximum section height is 27 in.
Maximum door height is 20 ft.
All doors, even those above the tested height, are available with jamb brackets or commercial full angle. The maximum spacing of the jamb brackets/track clips should be maintained.

John E. Scates, P.E.
2560 King Arthur Blvd. Ste 124-54
Lewisville, Texas 75056
Texas P.E. 56308/F2203

COMPLIES WITH IBC/IRC 2018 Professional Engineer seal provided only for verification of wind load construction details.

 320 Sycamore Wauseon, Ohio 43567 © Copyright 2014	DESCRIPTION: 16' 2" EXTRUDED ALUMINUM SERIES WIND LOAD SECTIONAL DOOR DESIGN PRESSURE +21.8/-24.3 PSF	
	DRAWING NO.: WLT-C300-0194-08-22-24	REV. A
	DRAWN BY: MVS DATE DRAWN: 11/1/18	REV. DATE: 2/17/22
	MODEL(S): See Sheet 3	SHEET: 1 OF 4

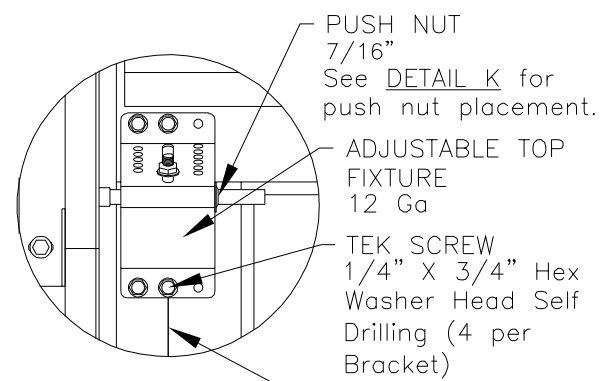

DETAIL A

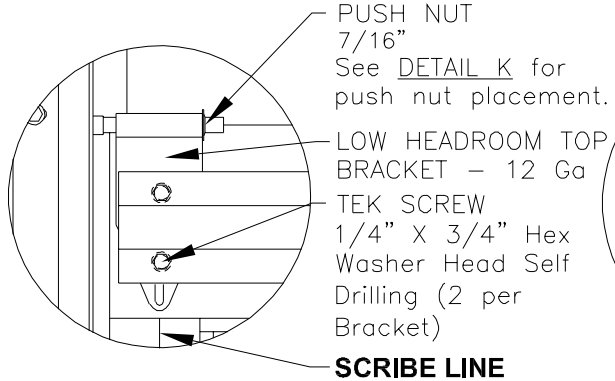

LOW HEADROOM TOP BRACKET

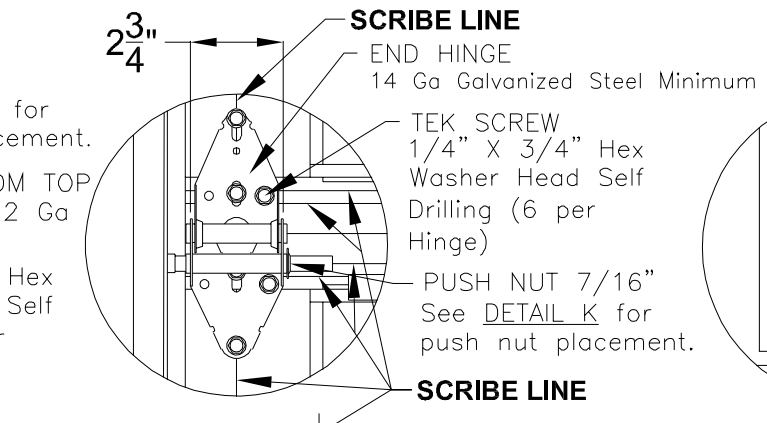

DETAIL B

Whenever possible all hardware should be attached to the sections with the Tek Screws located at the scribe line in the aluminum extrusion.

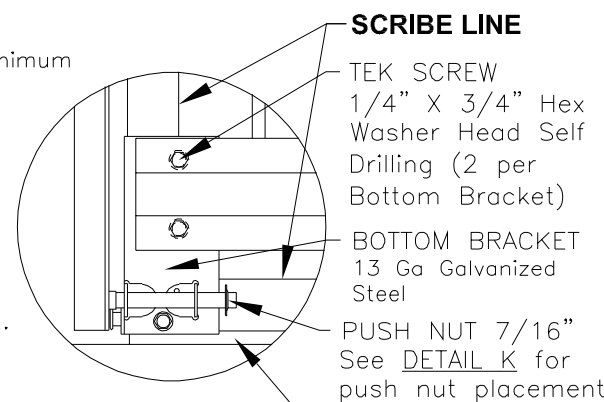

DETAIL C

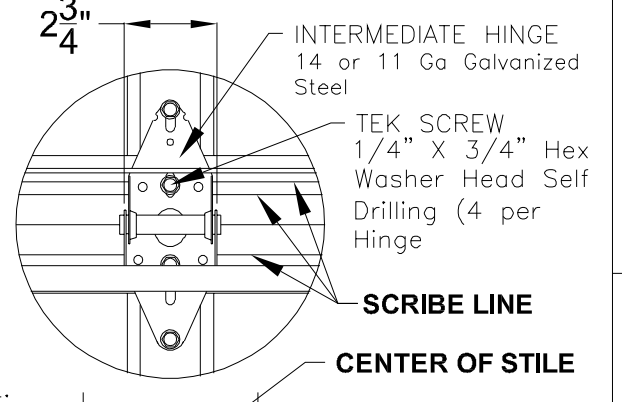

DETAIL D

When attaching hardware to the center stile make sure the Tek Screw is located in the center of the stile (No scribe line exists).

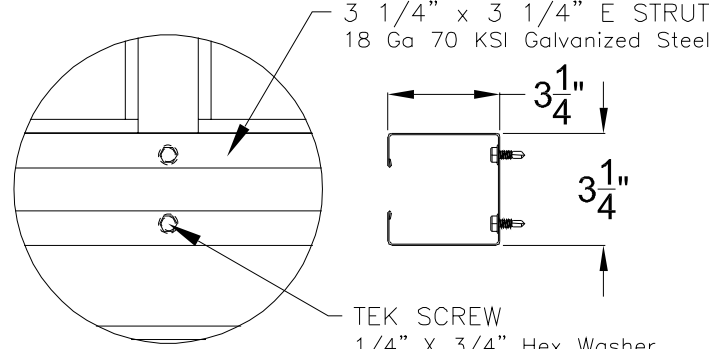

DETAIL E

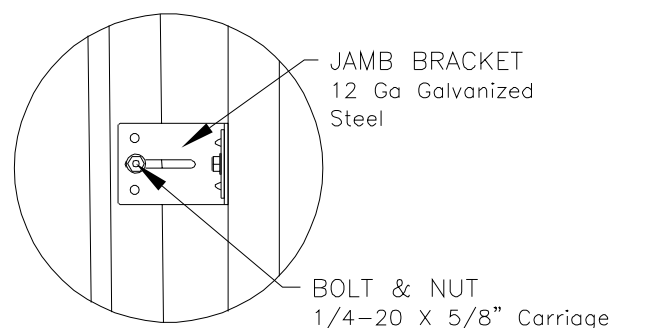

DETAIL F

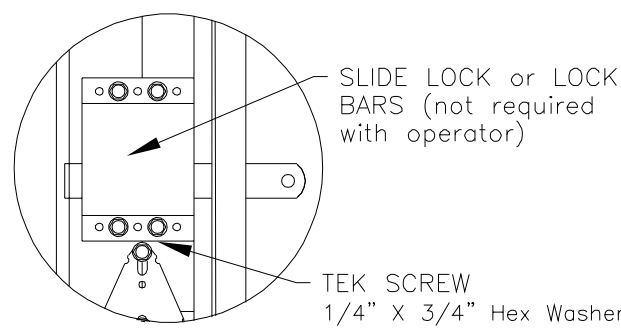

DETAIL G

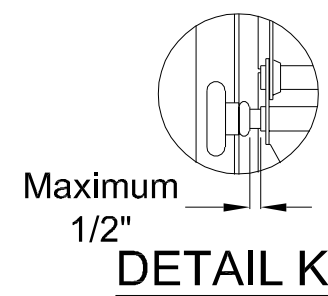

There should be a space of maximum 1/2" between the roller hub and the outside edge of the roller holder which is set by the push nut.

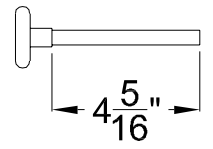

2" Diameter Nominal Eleven Ball Nylon or Ten Ball Steel with a Minimum Workable Shaft Length Shown.

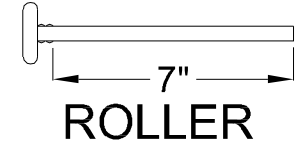

(FOR DOUBLE HARDWARE)
2" Diameter Nominal Eleven Ball Nylon or Ten Ball Steel with a Minimum Workable Shaft Length Shown.

NOTE: Details on some views omitted for clarity.
Double end stiles and double end hardware may be provided on wider or heavier doors.

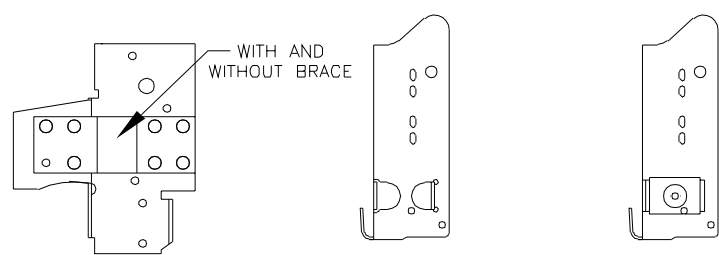

- RESIDENTIAL & LIGHT COMMERCIAL For Low Headroom With 2" Track and Single End Stiles
- COMMERCIAL For Standard, High & Vertical Lift With 2" Track and Single End Stiles
- COMMERCIAL For Standard, High & Vertical Lift With 3" Track and Single End Stiles
- COMMERCIAL HEAVY DUTY For Standard, High & Vertical Lift With 3" Track and Double End Stiles
- COMMERCIAL HEAVY DUTY For Low Headroom With 3" Track and Double End Stiles

ALTERNATE BOTTOM BRACKETS

NOTE: The bottom bracket tested (shown in DETAIL C) is the lightest bracket available.

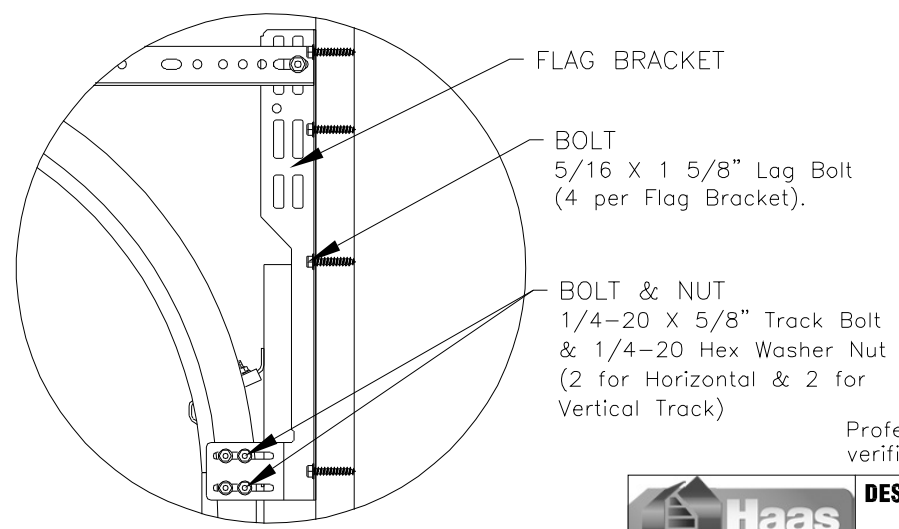

DETAIL H

John E. Scates, P.E.
2560 King Arthur Blvd. Ste 124-54
Lewisville, Texas 75056
Texas P.E. 56308/F2203

Professional Engineer seal provided only for verification of wind load construction details.

<p>320 Sycamore Wauseon, Ohio 43567 © Copyright 2014</p>	DESCRIPTION: 16' 2" EXTRUDED ALUMINUM SERIES WIND LOAD SECTIONAL DOOR DESIGN PRESSURE +21.8/-24.3 PSF	
	DRAWING NO.: WLT-C300-0194-08-22-24	REV.: A
	DRAWN BY: MVS	DATE DRAWN: 11/1/18
	MODEL(S): See Sheet 3	REV. DATE: 2/17/22
		SHEET: 2 OF 4

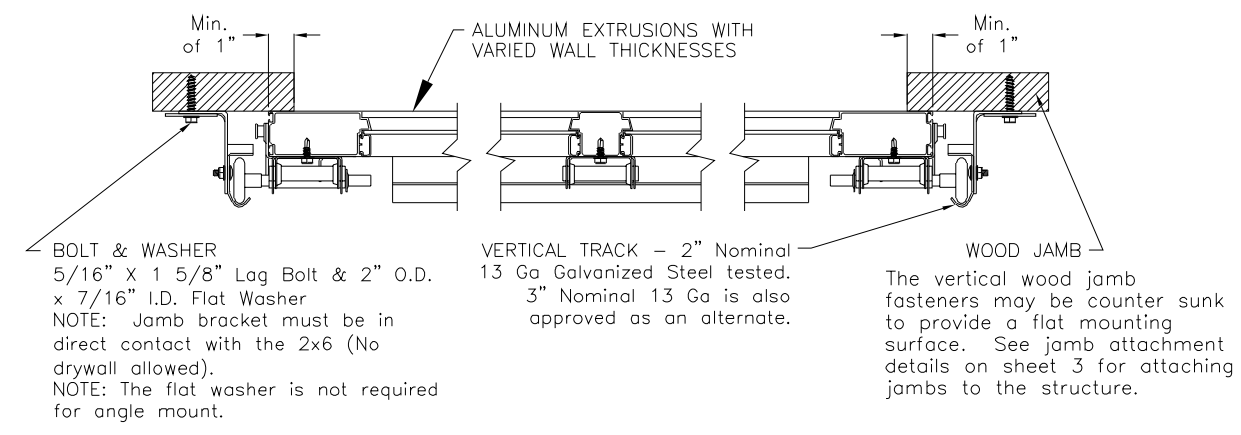
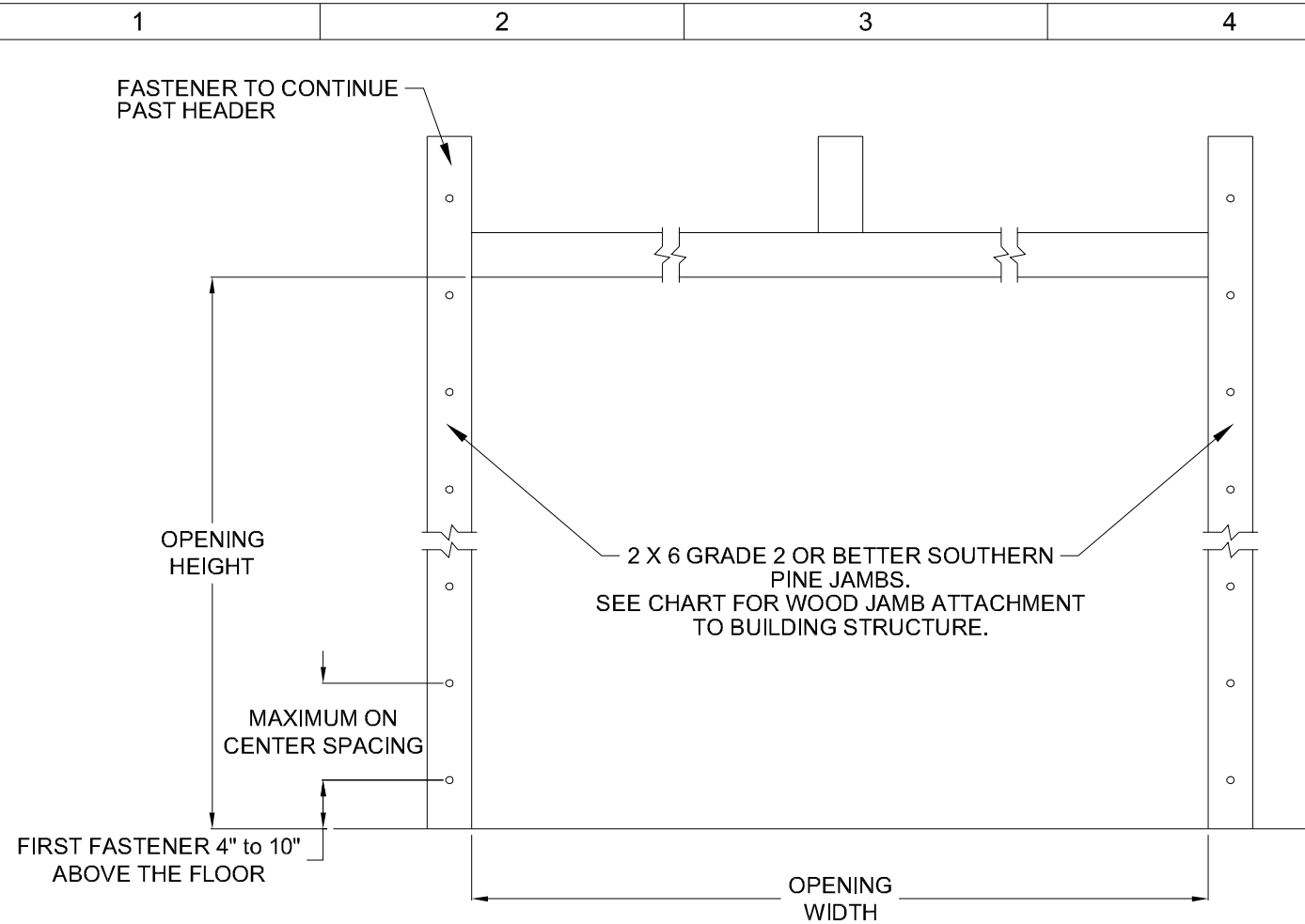

MODEL NUMBERS

MODEL NUMBERS AVAILABLE
RA 360 SERIES
CA 320 SERIES
RA 360i SERIES
CA 320i SERIES

WOOD JAMB ATTACHMENT						
Building Structure	Fastener Type	Minimum Embedment	Minimum Edge Distance	Minimum on Center Spacing	Maximum on Center Spacing	Allowable Tension Load
Min. 2500 PSI to 4000 PSI Concrete	Tapcon + (PLUS) 1/4" w/ 1" OD washer	2"	2.50"	5.00"	24"	551
Southern Pine	3/8" Lag w/ 1 1/8" OD washer	1.50"	1.50"	1.50"	24"	620
Spruce Pine Fir	3/8" Lag w/ 1 1/8" OD washer	1.50"	1.50"	1.50"	24"	482

NOTE: 2X6 mounted to the wall must be Southern Pine Grade 2 or better.

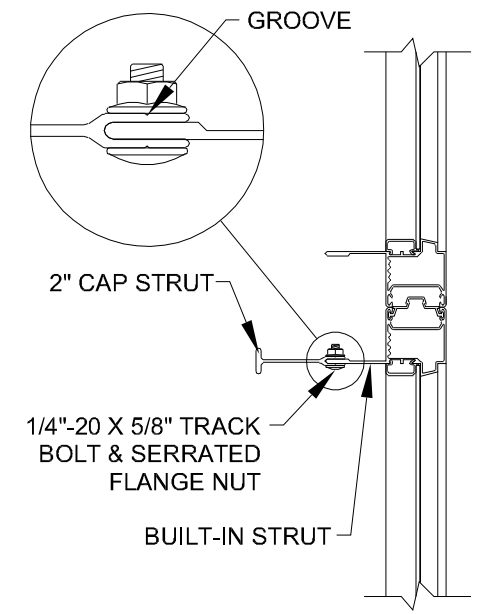

Section A-A
Scale: 4 = 1

NOTE: To install the cap strut, first center it horizontally with the built-in strut. Next tap on the flat end until it is fully engaged with the built-in strut. Fasten the two together using the provided track bolts. A bolt should be used at each hinge location and at the end of each cap strut. The end bolts should be located a minimum of 1" from the end of the cap strut. There is a groove in the cap strut that should be used as a guide for drilling the holes.

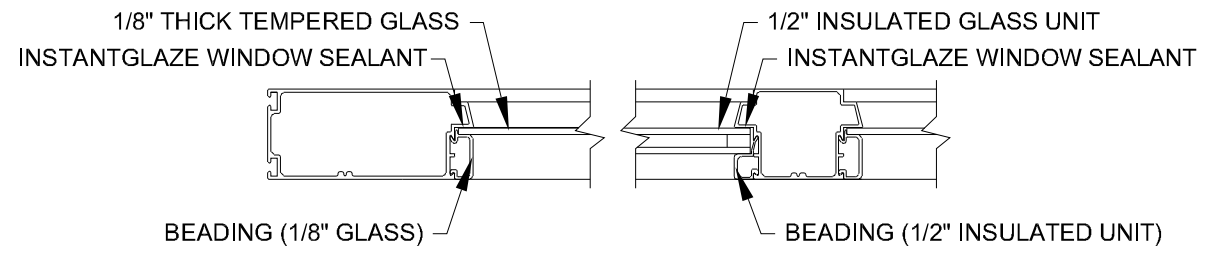

GLAZING DETAIL

NOTE: GLAZING IS AVAILABLE IN EITHER 1/8" THICK TEMPERED GLASS OR 1/2" INSULATED GLASS UNITS CONSISTING OF TWO PIECES OF 1/8" THICK TEMPERED GLASS AND A 1/4" SPACER. THE MAXIMUM GLASS SIZE IS 45 3/8" X 19 5/8" (OR DLO OF 44-1/2" X 19")

John E. Scates, P.E.
2560 King Arthur Blvd. Ste 124-54
Lewisville, Texas 75056
Texas P.E. 56308/F2203

Professional Engineer seal provided only for verification of wind load construction details.

<p>320 Sycamore Wauseon, Ohio 43567 © Copyright 2014</p>	DESCRIPTION:	
	16' 2" EXTRUDED ALUMINUM SERIES WIND LOAD SECTIONAL DOOR DESIGN PRESSURE +21.8/-24.3 PSF	
	DRAWING NO.: WLT-C300-0194-08-22-24	REV.: A
	DRAWN BY: MVS	DATE DRAWN: 11/1/18
MODEL(S): See Sheet 3	REV. DATE: 2/17/22	SHEET: 3 OF 4

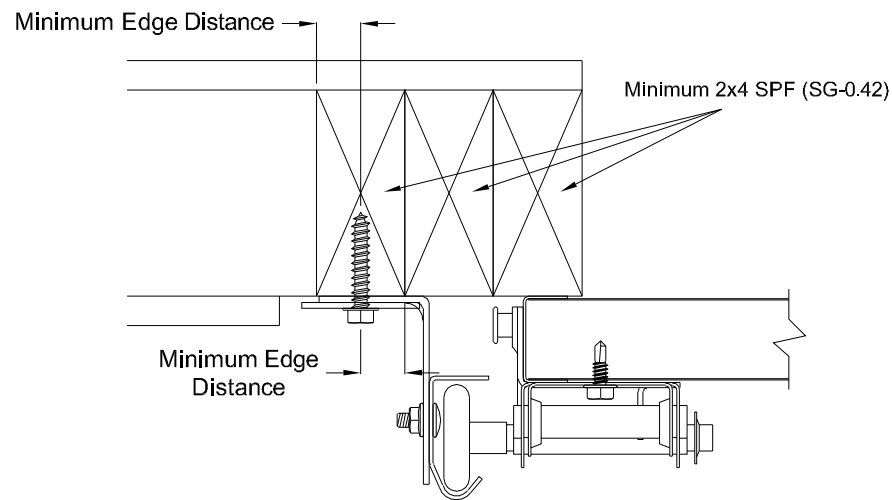

Direct Wood Mounting Detail

Bracket Mount Shown, Reverse and Continuous Angle Mount Also Approved As Alternate.

- 439 lbs. per anchor allowable load
- 5/16" Dia. Lag Screw w/1-1/8" O.D. Flat Washer (shall conform to ANSI/ASME standard B18.2.1)
- Minimum Screw Length: Spruce-Pine-Fur (SPF) - 2-1/2"
Southern Pine - 1-5/8"
- Minimum Edge Distance: 1/2"
- Maximum on Center Spacing: 24"

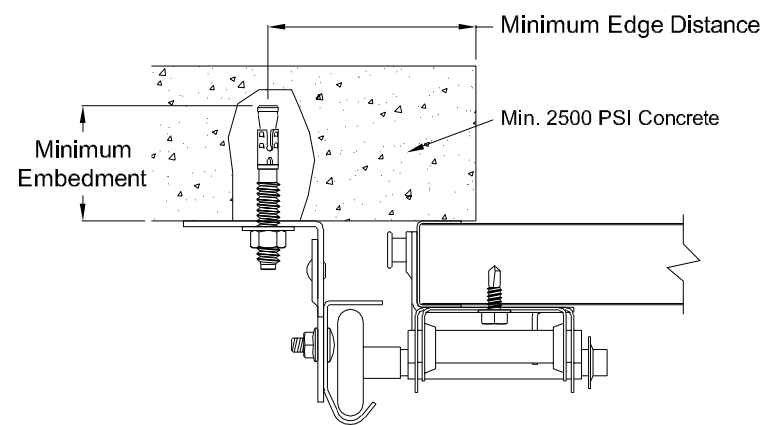

Direct Concrete Mounting Detail

Continuous Angle Clip Mount Shown, Bracket and Reverse Continuous Angle Mount Also Approved As Alternate.

- 831 lbs. per anchor allowable load
- 3/8" Dia. Ankr-Tite CCAT w/1-1/8" O.D. Flat Washer (by Wej-It Fastening Systems)
- Minimum Embedment: 2-5/8"
- Minimum Edge Distance: 2-1/2"
- Minimum on Center Spacing: 6"
- Maximum on Center Spacing: 24"

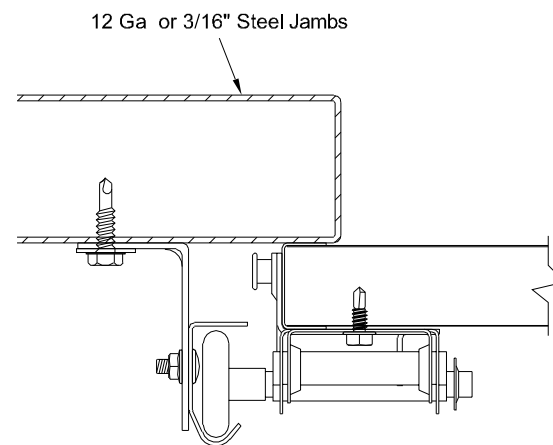

Direct Steel Mounting Detail

Bracket Mount Shown, Reverse and Continuous Angle Mount Also Approved As Alternate.

- 232 lbs. per anchor allowable load - 12 Ga Steel
- 569 lbs. per anchor allowable load - 3/16" Ga Steel
- 5/16"-12 Tek Self-Drilling Screw w/9/16" O.D. Flat Washer
- 12 Ga Maximum on Center Spacing: 16"
- 3/16" Maximum on Center Spacing: 24"

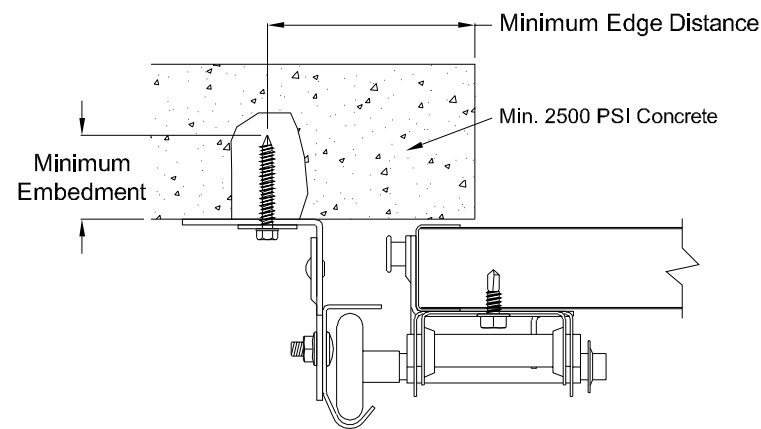

Direct Concrete Mounting Detail

Continuous Angle Clip Mount Shown, Bracket and Reverse Continuous Angle Mount Also Approved As Alternate.

- 562 lbs. per anchor allowable load
- 1/4" Dia. Concrete Self-Tapping & Wedge Anchor w/1" O.D. Flat Washer (Includes Tapcon+ (by ITW), Wedge-Bolt+ (by Powers Fasteners) & Red Head TruBolt wedge anchor (by ITW))
- Minimum Embedment: 2"
- Minimum Edge Distance: 2-1/2"
- Minimum on Center Spacing: 5"
- Maximum on Center Spacing: 24"

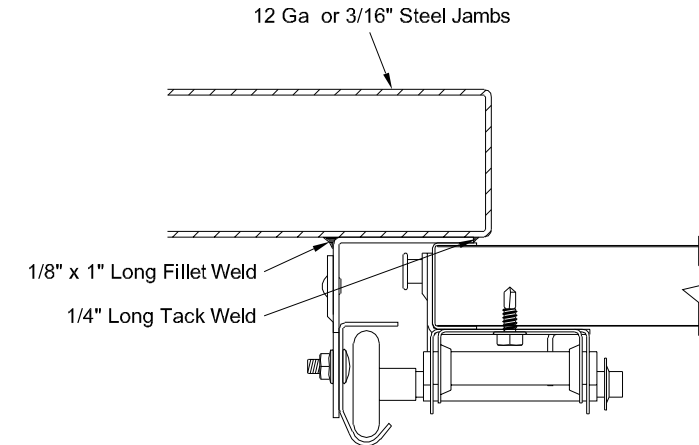

Direct Steel Mounting Detail

Reverse Continuous Angle Clip Mount Shown, Continuous Angle Mount Also Approved As Alternate.

- 1272 lbs. per anchor allowable load
- 1/8" Nom. x 1" Long Fillet and 1/4" Long Tack Weld (E60xx Electrodes Min.)
- Welds performed by a certified welder or inspected by a certified welding inspector to verify integrity of the welds.
- Maximum on Center Spacing: Apply welds at each roller location not to exceed 24"

John E. Scates, P.E.
2560 King Arthur Blvd. Ste 124-54
Lewisville, Texas 75056
Texas P.E. 56308/F2203

Professional Engineer seal provided only for verification of wind load construction details.



DESCRIPTION:
16' 2" EXTRUDED ALUMINUM SERIES
WIND LOAD SECTIONAL DOOR
DESIGN PRESSURE +21.8/-24.3 PSF

DRAWING NO.: WLT-C300-0194-08-22-24 **REV.:** A

DRAWN BY: MVS **DATE DRAWN:** 11/1/18 **REV. DATE:** 2/17/22

MODEL(S): See Sheet 3 **SHEET: 4 OF 4**

320 Sycamore
Wauseon, Ohio 43567
© Copyright 2014