

NOTES:

- VINYL OR WOOD DOOR STOP NAILED A MAXIMUM OF 6" O.C. MUST OVERLAP TOP AND BOTH ENDS OF PANELS MINIMUM 7/16" TO MEET NEGATIVE PRESSURES.
- SLIDE LOCK OR OPERATOR REQUIRED. LOW HEADROOM REQUIRES A LOCK ON THE LEFT AND RIGHT SIDE OF THE DOOR.
- THE DESIGN OF THE SUPPORTING STRUCTURAL ELEMENTS SHALL BE THE RESPONSIBILITY OF THE PROFESSIONAL OF RECORD FOR THE BUILDING OR STRUCTURE AND IN ACCORDANCE WITH CURRENT BUILDING CODES FOR THE LOADS LISTED ON THIS DRAWING.
- SECTION STEEL TO HAVE THE FOLLOWING MINIMUM THICKNESS:
EXTERIOR - 27 GA
INTERIOR - 30 GA
- DOOR JAMB TO BE MINIMUM 2x6 STRUCTURAL GRADE LUMBER AND BE SPRUCE, PINE, OR FIR. REFER TO JAMB CONNECTION SUPPLEMENT FOR ATTACHMENT TO SUPPORTING STRUCTURE.
- FOR LOW HEAD ROOM LIFT CONDITIONS, TOP BRACKET SHALL BE A LHR TOP BRACKET IN LIEU OF THE BRACKET SHOWN ON THIS DRAWING. SEE LHR, DETAIL A, SHEET 2.
- GLAZING OPTIONS - .125" MINIMUM TEMPERED GLAZING INSTALLED IN TOP SECTION (WITH OR WITHOUT DECORATIVE LITE FRAME DIVIDERS) MEETS UNIFORM STATIC WIND PRESSURES SHOWN ON THIS DRAWING. GLAZING IS NOT IMPACT RESISTANT AND DOES NOT MEET THE REQUIREMENTS FOR WIND-BORNE DEBRIS REGIONS. MAX CLEAR OPENING 49-1/4" X 19-1/4".
- 11 GA ROLLER SLIDES WITH WELDED ENDS AND 11 GA REINFORCING BRACKET REQUIRED FOR DOORS > 8' TALL

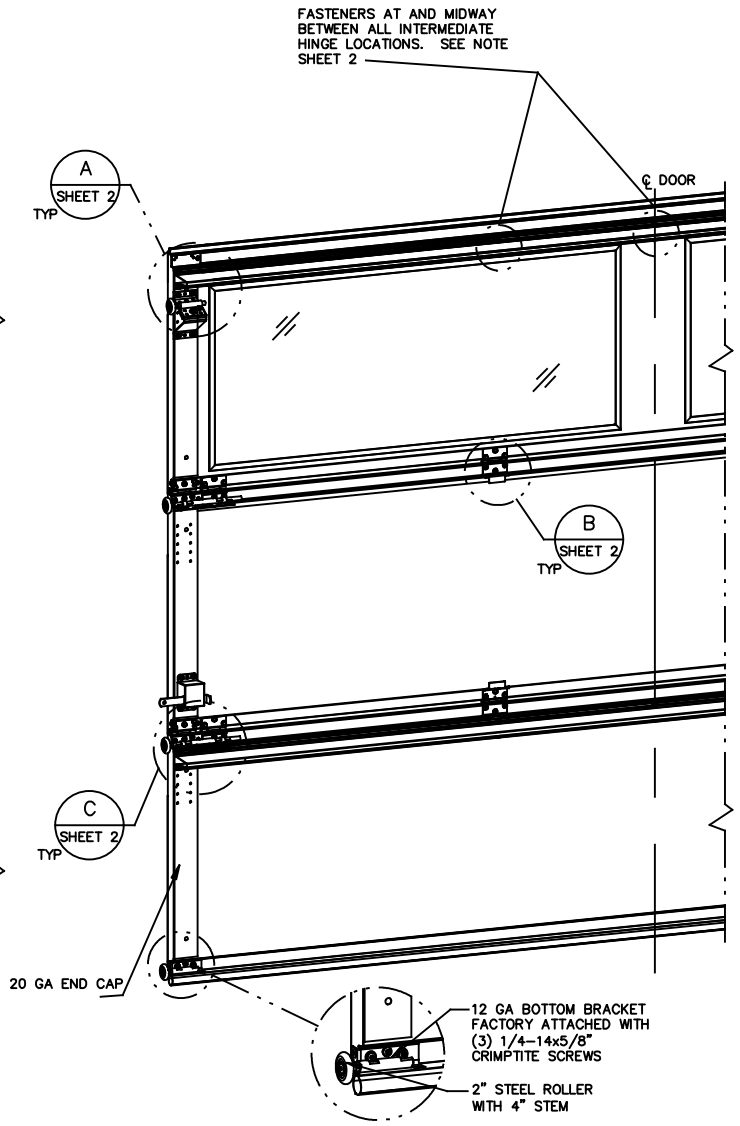
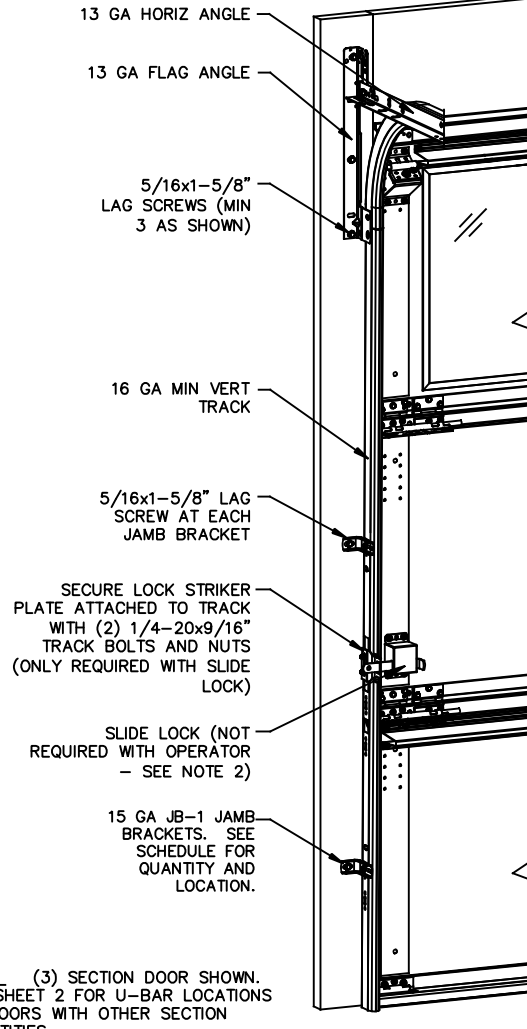

NOTE: (3) SECTION DOOR SHOWN. SEE SHEET 2 FOR U-BAR LOCATIONS ON DOORS WITH OTHER SECTION QUANTITIES.

JAMB BRACKET SCHEDULE				
DOOR HEIGHT	NO. OF SECTIONS	NO. OF JAMB BRACKETS (EACH JAMB)	TRACK TYPE	LOCATION OF CENTERLINE OF JAMB BRACKETS MEASURED FROM BOTTOM OF TRACK (ALL DIMENSIONS ± 2")
7'-0"	3	2	FAT	13" (JB), 45" (JB)
8'-0"	4	3	FAT	10" (JB), 48" (JB), 66" (JB)
> 8'-0"				SEE NOTE BELOW

NOTE: (JB) FOLLOWING DIMENSION DENOTES SLOTTED JAMB BRACKET ATTACHED TO TRACK WITH 1/4-20x9/16" TRACK BOLT AND NUT. ALL DOORS GREATER THAN 8' IN HEIGHT REQUIRE USE OF CONTINUOUS WALL ANGLE. SEE SUPPLEMENT TRACK CHART FOR DETAILS.

SUPERIMPOSED DESIGN PRESSURE LOADS ON SUPPORTING STRUCTURE		
DOOR WIDTH	DOOR HEIGHT	UNIFORM LOAD EACH JAMB (PLF)
10'-0"	ALL	+64.0/-74.0



Lewisville, TX

PROFESSIONAL ENGINEER'S SEAL PROVIDED ONLY FOR VERIFICATION OF WINDLOAD CONSTRUCTION DETAILS.

REVISIONS
P00 CREATED NEW DRAWING FOR WINDLOAD OPTIONS 8-23-16 GAC

This door has been tested per ANSI/DASMA 108

STATIC PRESSURE RATINGS		APPROVED SIZES		SCALE: N.T.S.		SIZE: A
DESIGN (PSF):	+12.80/-14.80	MAX WIDTH:	10'-0"	DATE	NAME	
IMPACT/CYCLIC RATED (YES/NO): NO		MAX HEIGHT:	14'-0"	DRAWN	8-23-16 GAC	
		MAX SECTION HEIGHT:	28"	CHECKED	8-23-16 DK	
MODELS 300-309/5800				SHEET 1 OF 2		
WINDLOAD SPECIFICATION				DRAWING PART NO.	REV.	
				411426	P00	

JOHN E. SCATES, PE
3121 FAIRGATE DR.
CARROLLTON, TX 75007
FL PE 51737 TX PE 56308/F-2203

