

NOTES:

1. REGAL SHOWN, CELEBRITY, AMERICAN 100, CS, XL, CSX OR CSL SERIES MAY BE SUBSTITUTED.
2. STRUTS ATTACHED WITH 2 SELF DRILLING SCREWS 1/4"-20 X 3/4" AT EACH STILE LOCATION
3. 4 SECTION HIGH DOOR SHOWN (7FT) TALLER DOOR CONFIGURATIONS MAY BE CONSTRUCTED UP TO A MAXIMUM OF 14FT HIGH, USING SAME PANEL CONSTRUCTION AS SHOWN (MAXIMUM SECTION HEIGHT OF 21").
4. MINIMUM STEEL THICKNESS FOR SECTION IS 25 GA. (.0185").
5. SECTIONS EMBOSSED 14.00"x20.375" ,16" X20.375", 14"x41", 16"x40" OR SECTIONS WITHOUT EMBOSSEMENT MAY ALSO BE USED. (LOCATION AND QUANTITY OF CENTER STILES MUST BE THE SAME).
6. TORSION SPRINGS OR EXTENSION SPRINGS AVAILABLE.
7. LOCK MUST BE ATTACHED AT EACH SIDE OF THE DOOR. CAM & BAR LOCKS OR AN OPENER MAY BE SUBSTITUTED.
8. WOOD MOUNT SHOWN, STEEL AND MASONRY ANGLE AND REVERSE ANGLE MOUNT AVAILABLE. NUMBER OF JAMB BRACKET ANCHOR LOCATIONS MUST BE THE SAME.
9. JAMB DETAIL IN ACCORDANCE WITH DWG. # RCWL-0001
10. THIS DOOR HAS NOT BEEN TESTED FOR WIND-BORNE DEBRIS.
11. USE THIS DRAWING IN CONJUNCTION WITH INSTALLATION INSTRUCTIONS. WHERE THE DRAWING CONFLICTS WITH OTHER INSTALLATION INSTRUCTIONS, THIS DRAWING GOVERNS.

Strut Requirements

# sections	# Struts
	3"
4	7
5	9
6	10
7	12
*8	14

*SEE NOTE 4

Track Bracket Locations

DOOR HEIGHT	"A"	"B"	"C"	"D"
6'-6" thru 7'-0"	4"	21"	42"	X
7'-6" Thru 8'-9"	4"	21"	42"	60"

For Doors over 9' high one Jamb bracket per section must be added and positioned within 3" of the roller.

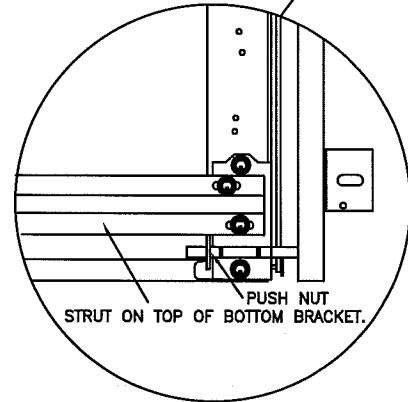
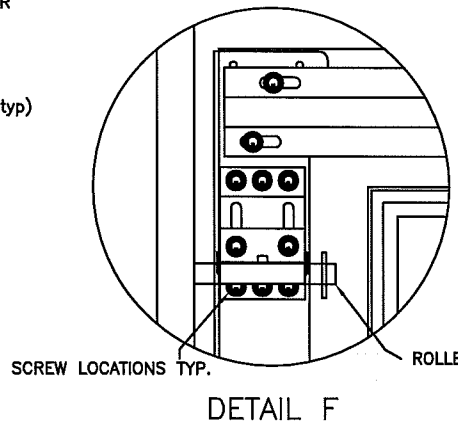
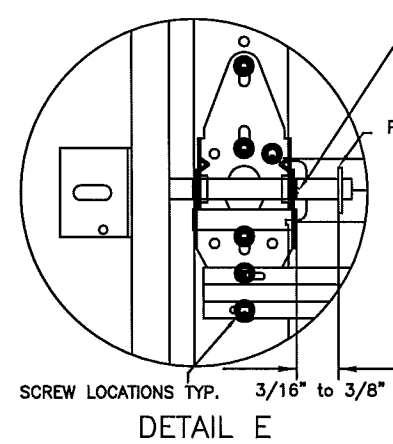
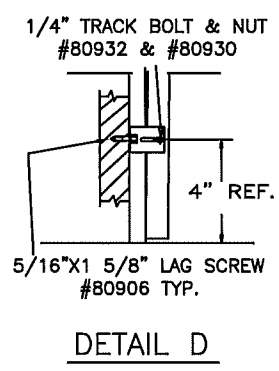
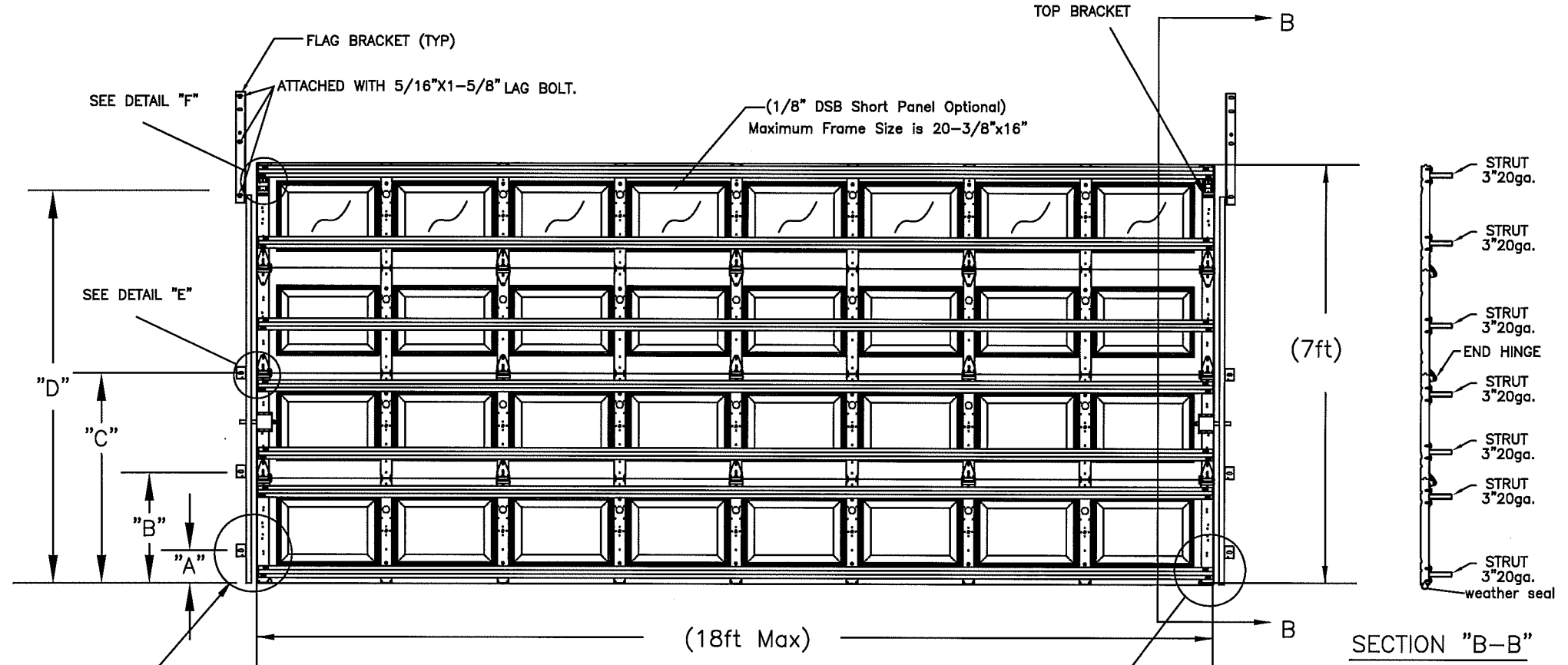

SECTION "B-B"

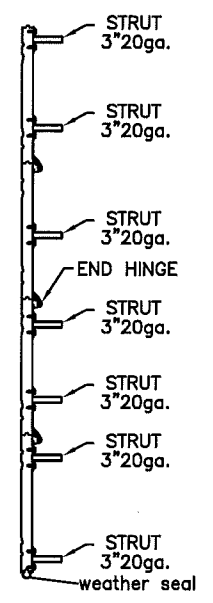

DESIGN LOAD +18.5/-20.7

PROFESSIONAL ENGINEER'S SEAL PROVIDED ONLY FOR VERIFICATION OF WINDLOAD CONSTRUCTION DETAILS

John E. Scates
8/6/12

JOHN E. SCATES, P.E.
3121 FAIRGATE
CARROLLTON, TX
FL. P.E. # 51737
TX. P.E. # 56308, F-2203

This product was tested/evaluated in accordance with ANSI/DASMA 108-05

NOTES: THIS DRAWING AND / OR TECHNICAL INFORMATION ON THIS SHEET IS THE PROPERTY OF MID-AMERICA DOOR COMPANY AND IS LOANED IN CONFIDENCE FOR ENGINEERING AND MUTUAL ASSISTANCE PURPOSES ONLY, AND MAY NOT BE REPRODUCED OR USED TO MANUFACTURE ANYTHING DISCLOSED HEREON WITHOUT THE EXPRESSED PERMISSION OF MID-AMERICA DOOR COMPANY.

Rev.	By	Date	Description	Rev.	By	Date	Description	SCALE	N.T.S.	DATE
0	BR	4/24/08	NEW DRAWING	8						
1	BR	1/12/12	UPDATED FOR 2010 FIBC	9						
2	BR	7/27/12	UPDATED NOTES	10						
3				11						
4				12						
5				13						
6				14						
7				15						

INITIAL CHK. BJR	07-22-08		DESCRIPTION	REGAL/ CELEBRITY WINDLOAD SERIES
FINAL CHK.			TITLE	WINDLOAD CONSTRUCTION DETAILS
ENGR.			DWG. NO.	RCWL3-1807
APPR. BY			SHT. OF	1 OF 2

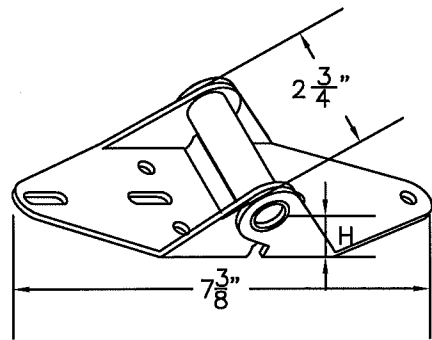

P/N 20604 (#1 HINGE)

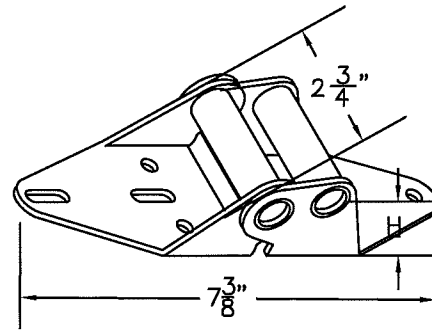

END HINGE

HINGE #	GAGE #	"H"	PART NUMBER
1	14	3/4"	20602
2	14	1"	20606
3	14	1 1/4"	20610
4	14	1 1/2"	20614
5	14	1 3/4"	20616
6	13	2"	20618

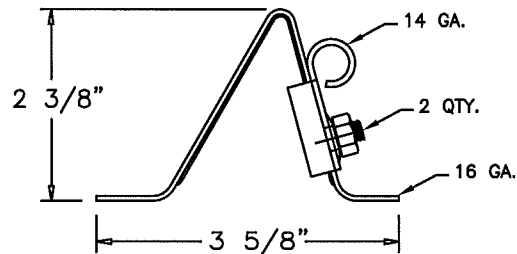
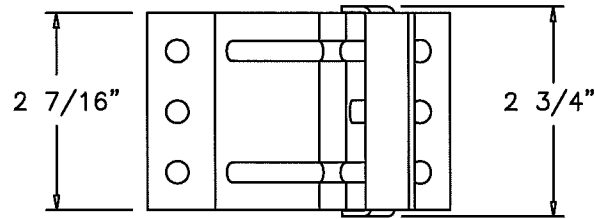

P/N 20356 TOP FIXTURE

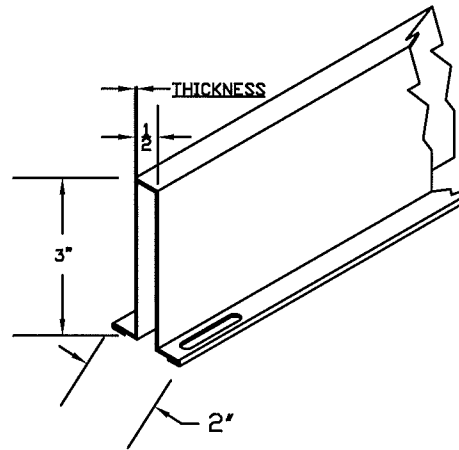

3" STRUT

THICKNESS OF STRUTS ARE AS STATED BELOW		
3" 20 GAUGE 50 KSI MINIMUM YIELD		.036" MIN.

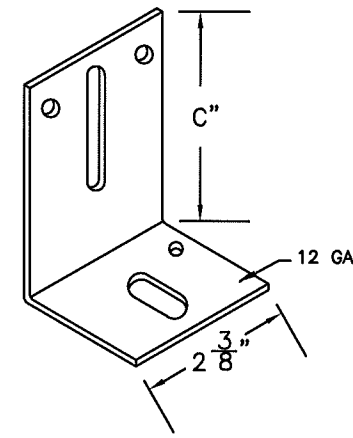

TRACK BRACKET

BRACKET #	"C"	PART NUMBER
4	3"	20368
5	3 1/4"	20370
6	3 1/2"	20372
7	3 3/4"	20374
8	4"	20376
9	4 3/4"	20378

NOTES:

1. STRUTS ARE NOT MORE THAN 1 1/2" SHORTER THAN SECTION.
2. USE IN CONJUNCTION WITH INSTALLATION INSTRUCTIONS. WHERE THE DRAWING CONFLICTS WITH OTHER INSTALLATION INSTRUCTIONS, THIS DRAWING GOVERNS.

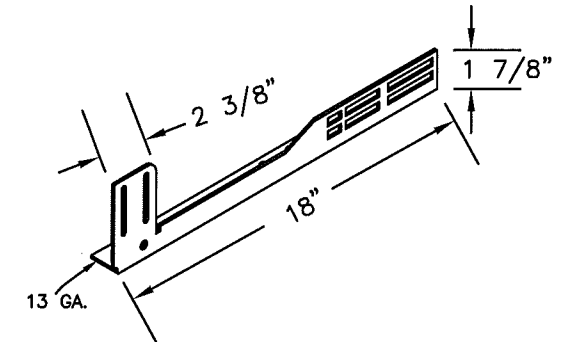

20366 & 7 FLAG BRACKET

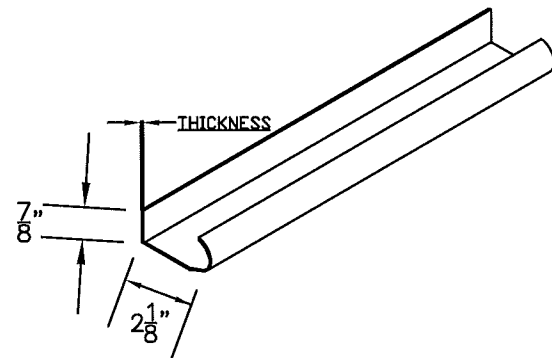

WINDLOAD TRACK

THICKNESS OF TRACK IS AS STATED BELOW		
VERTICAL TRACK IS MIN. 16 GA.		.058" MIN
HORIZONTAL TRACK IS MIN. 16 GA.		.058" MIN

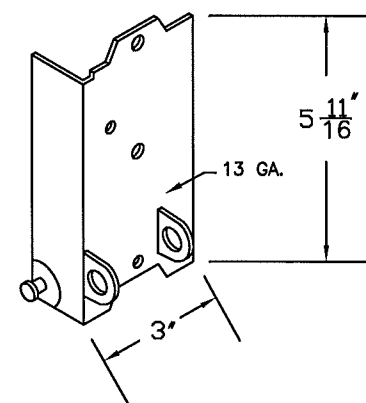

P/N 20334&5 BOTTOM BRKT.

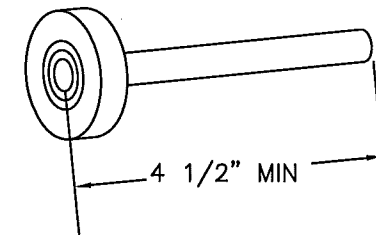

P/N 20804 SHORT STEM 10 BALL ROLLER

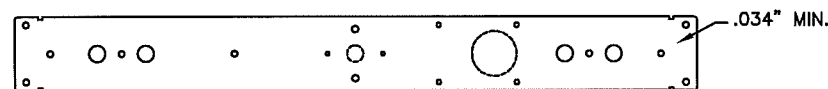

P/N 10455 & 10465 (21" & 18") CENTER STILE

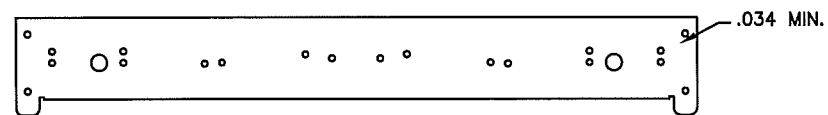

P/N 10450 & 10460 (21" & 18") END STILE

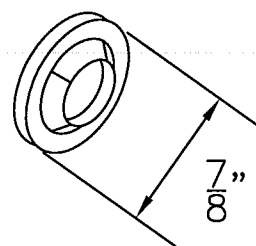

P/N 20239 PUSH NUT

Professional Engineer's Seal for John E. Scates, P.E., State of Texas, No. 56308, dated 8/6/12.

PROFESSIONAL ENGINEER'S SEAL PROVIDED ONLY FOR VERIFICATION OF WINDLOAD CONSTRUCTION DETAILS

JOHN E. SCATES, P.E.
3121 FAIRGATE
CARROLLTON, TX
FL. P.E. # 51737
TX. P.E. # 56308, F-2203

NOTES: THIS DRAWING AND / OR TECHNICAL INFORMATION ON THIS SHEET IS THE PROPERTY OF MID-AMERICA DOOR COMPANY AND IS LOANED IN CONFIDENCE FOR ENGINEERING AND MUTUAL ASSISTANCE PURPOSES ONLY, AND MAY NOT BE REPRODUCED OR USED TO MANUFACTURE ANYTHING DISCLOSED HEREON WITHOUT THE EXPRESSED PERMISSION OF MID-AMERICA DOOR COMPANY.

Rev.	By	Date	Description	Rev.	By	Date	Description	SCALE	N.T.S.	DATE
0	BJR	4/24/08	NEW DRAWING	8						
1	BJR	1/12/12	UPDATED FOR 2010 FBC	9						07-22-08
2	BJR	7/27/12	UPDATED NOTES	10						
3				11						
4				12						
5				13						
6				14						
7				15						

DRAWN BY BJR		INITIAL CHK. BJR		FINAL CHK. JAR		ENGR.		APPR. BY JAR	
DESCRIPTION: WINDLOAD SERIES HARDWARE TITLE: WINDLOAD CONSTRUCTION DETAILS DWG. NO.: RCWL3-1807 SHT. 2 OF 2 REV. 2									