

MODELS		INSULATED
STANDARD		
CLOPAY	G4S, GS4, G4L, GL4, GD4S, GD4L, GR4S, GR4L	G4SV, GS4V, G4LV, GL4V, GD4SV, GD4LV, GR4SV, GR4LV,
IDEAL	E4S, E4L, ED4S, ED4L	E4SV, E4LV, ED4SV, ED4LV
HOLMES	SS4, SL4, AR4S, AR4L	SS4V, SL4V, AR4SV, AR4LV

MIN. (1) INTERMEDIATE STILE ATTACHED W/ TOG-L-LOC (TOP & BOT) AND URETHANE ADHESIVE.

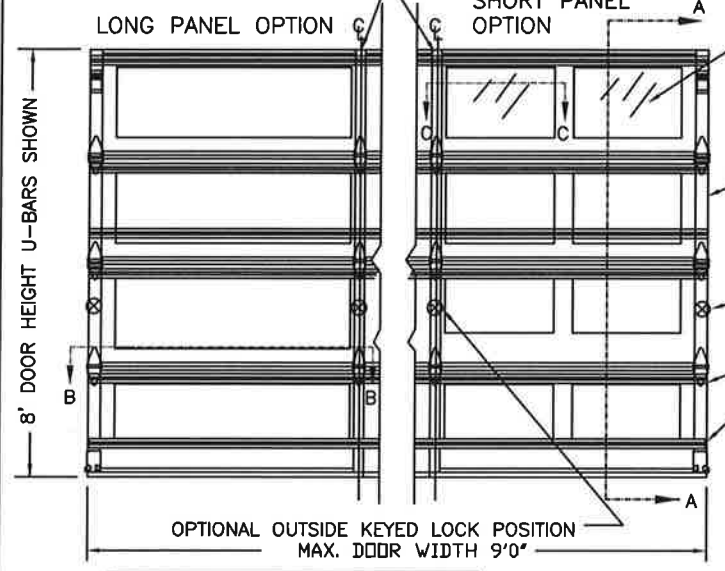

OPTIONAL WINDOW LITES DSB GLASS AVAILABLE (SEE SECTION C-C)
(MAX CUT-OUT NOT TO EXCEED 18-5/8" WIDE X 15-1/16" TALL)

20 GA. MIN. END STILES ATTACHED TO DOOR SKIN WITH PATENTED TOG-L-LOC SYSTEM (TOP, BOTTOM & CENTER).

LOCK POSITION (BOTH SIDES) TWO POINT LOCKING

SECTIONS WITH ONE U-BAR POSITION AT TOP OF SECTION AS SHOWN OVER HINGES.
SECTIONS WITH TWO U-BARS POSITION ONE AT TOP AND ONE AT BOTTOM OF SECTION ABOVE HINGE OR ABOVE BOTTOM BRACKET AS SHOWN. (SEE HEIGHT CHART FOR U-BAR ARRANGEMENT)

DOOR AVAILABLE IN SHORT OR LONG EMBOSS. DOOR MAY CONSIST OF A MIXTURE OF LONG AND SHORT PANEL SECTIONS.

DOOR HEIGHT	# OF SECTIONS
6'-0"	3
6'-3" TO 8'-0"	4
8'-3" TO 10'-0"	5
10'-3" TO 12'-0"	6
12'-3" TO 14'-0"	7
14'-3" TO 16'-0"	8
MAX SECTION HEIGHT:	24"

GALLERY 24GA W5-09		NO. OF U-BARS PER SECTION							
DOOR HEIGHT	SECTION NUMBER								
		1	2	3	4	5	6	7	8
6	1								
6	2								
6	3								
6	4								
6	5								
6	6								
6	7								
6	8								
6	9								
6	10								
6	11								
6	12								
6	13								
6	14								
6	15								
6	16								
6	17								
6	18								
6	19								
6	20								
6	21								
6	22								
6	23								
6	24								
6	25								
6	26								
6	27								
6	28								
6	29								
6	30								
6	31								
6	32								
6	33								
6	34								
6	35								
6	36								
6	37								
6	38								
6	39								
6	40								
6	41								
6	42								
6	43								
6	44								
6	45								
6	46								
6	47								
6	48								
6	49								
6	50								
6	51								
6	52								
6	53								
6	54								
6	55								
6	56								
6	57								
6	58								
6	59								
6	60								
6	61								
6	62								
6	63								
6	64								
6	65								
6	66								
6	67								
6	68								
6	69								
6	70								
6	71								
6	72								
6	73								
6	74								
6	75								
6	76								
6	77								
6	78								
6	79								
6	80								
6	81								
6	82								
6	83								
6	84								
6	85								
6	86								
6	87								
6	88								
6	89								
6	90								
6	91								
6	92								
6	93								
6	94								
6	95								
6	96								
6	97								
6	98								
6	99								
6	100								

1# DENSITY POLYSTYRENE FOAM INSULATION 1-5/16" THICK WITH VINYL HAIRCELL BACKER (INSULATED MODELS ONLY)

24 GA. MIN. STEEL SKIN COATED WITH GALV., BAKED-ON PRIMER, AND A BAKED-ON POLYESTER TOP COAT APPLIED TO BOTH SIDES OF STEEL SKIN.

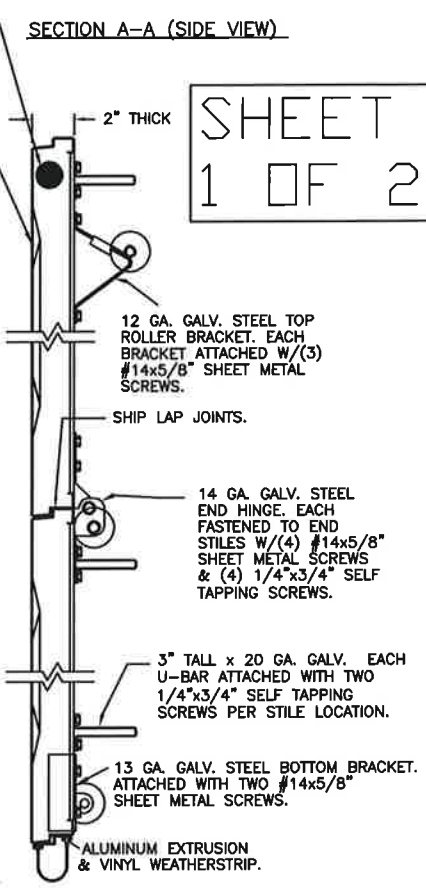

SHEET 1 OF 2

REV	DATE	DESCRIPTION
04	07/26/07	ADDED UPDATED GLAZING OPTION
05	12/05/07	ADDED LONG WINDOW LITE OPTION
06	01/31/12	REVISED WIND SPEED TABLE FOR ASCE7-10.
07	08/17/12	REVISED FOR TDI.
08	06/05/13	REMOVED ACRYLIC GLAZING. REVISED GLAZING SIZE.
09	08/2016	REMOVED WIND SPEED TABLE.
10	11/23/20	UPDATED TITLE BLOCK AND ADDED COMPLIANCE STATEMENT.

THIS PRODUCT COMPLIES WITH THE 2018 IBC/IRC.

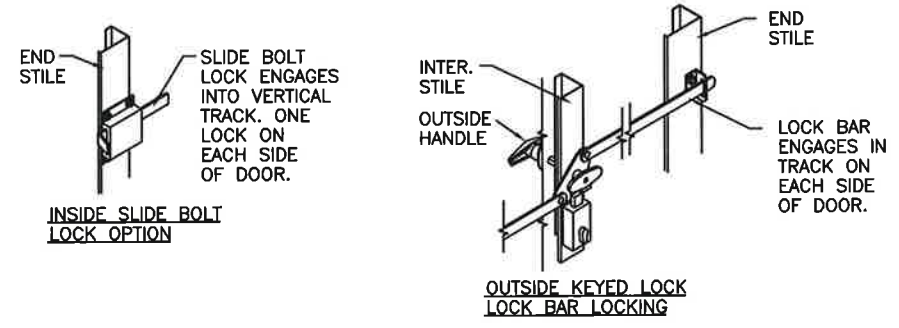
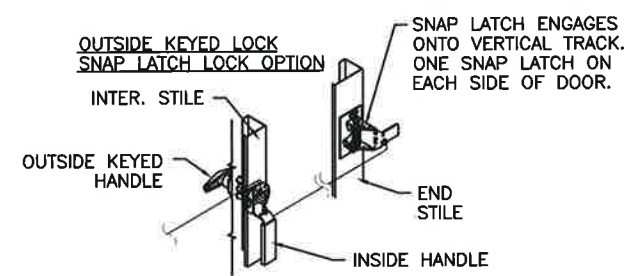
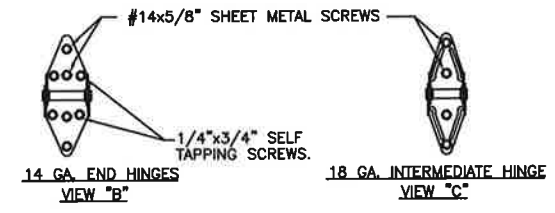

EQUIVALENT SECTION CONSTRUCTION: FOR ANY OF THE MODELS LISTED ON THIS DRAWING, THE FOLLOWING W-LEVEL DOORS USE EQUIVALENT SECTIONS (UP TO THE MAXIMUM WIDTH ALLOWED ON THIS DRAWING).

W3, W4, W5.

ANY OF THESE W-LEVELS MAY BE SHOWN ON THE OPTIONAL SHIPPING LABEL ON THE END STILE.

IN THE CASE OF GYPSUM WALLBOARD LOCATED AT OR NEAR THE DOOR OPENING LOCATION THERE ARE TWO ACCEPTABLE ALTERNATIVES:

- 1) THE WALLBOARD CAN BE CUT AWAY FROM THE DOOR OPENING AND 2X6 SOUTHERN YELLOW PINE WOOD JAMBS MOUNTED DIRECTLY TO THE SUPPORTING STRUCTURE TO CREATE THE MOUNTING SURFACE. ALTERNATIVELY, THE BRACKETS MAY BE ATTACHED DIRECTLY TO THE SUPPORTING STRUCTURE. SEE DETAIL BELOW. THE CENTER OF SCREW HOLE MUST BE AT LEAST 1/2" FROM BOTH EDGES FOR A 5/16" LAG SCREW.
- 2) IF THE WALLBOARD IS NOT CUT AWAY TO EXPOSE THE UNDERLYING STRUCTURE (WOOD FRAMING MEMBERS), A 2X6 SOUTHERN YELLOW PINE WOOD BUCK OVER SHALL BE INSTALLED THE WALLBOARD FRAMING THE OPENING USING THE JAMB ATTACHMENT FASTENERS LISTED BELOW. HOWEVER, THE JAMB ATTACHMENT FASTENERS MUST BE OF A SUFFICIENT INCREASED LENGTH TO ACCOUNT FOR THE THICKNESS OF THE WALLBOARD TO ENSURE PROPER FASTENER EMBEDMENT INTO THE STRUCTURAL FRAMING MEMBERS OF THE SUPPORTING STRUCTURE.

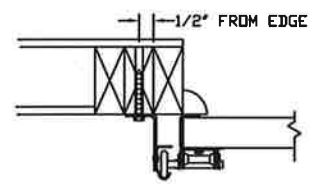

NOTE: THE DESIGN OF THE SUPPORTING STRUCTURAL ELEMENTS SHALL BE THE RESPONSIBILITY OF THE PROFESSIONAL OF RECORD FOR THE BUILDING OR STRUCTURE AND IN ACCORDANCE WITH CURRENT BUILDING CODES FOR THE LOADS LISTED ON THIS DRAWING.

PREPARATION OF JAMBS BY OTHERS.

VERTICAL JAMB ATTACHMENT (WOOD FRAME BUILDINGS): 3/8"x3" LAG SCREWS ON 24" CENTERS. 1-1/8" O.D. WASHER REQUIRED. LAG SCREWS MAY BE COUNTERSUNK (BUT NOT REQUIRED) TO PROVIDE A FLUSH MOUNTING SURFACE. HORIZONTAL JAMBS DO NOT TRANSFER LOAD.

VERTICAL JAMB ATTACHMENT (C-90 BLOCK OR 2,000 PSI MIN. CONCRETE COLUMN): 3/8"x3" SLEEVE ANCHOR BOLTS ON 24" CENTERS (2,000 PSI MIN. CONCRETE). WASHERS INCLUDED WITH SLEEVE ANCHORS.

OR 1/4"x3" TAPCON SCREWS ON 24" CENTERS (2,000 PSI MIN. CONCRETE) OR 24" CENTERS (C-90 BLOCK), 1" O.D. WASHERS REQUIRED WITH TAPCONS. ANCHORS MAY BE COUNTERSUNK (BUT NOT REQUIRED) TO PROVIDE A FLUSH MOUNTING SURFACE. HORIZONTAL JAMBS DO NOT TRANSFER LOAD.

OTHER JAMB CONFIGURATIONS: REFER TO DASMA TDS-161. A LICENSED DESIGN PROFESSIONAL MAY ALSO BE EMPLOYED TO APPROVE ALTERNATE FASTENERS AND/OR JAMB CONFIGURATIONS.

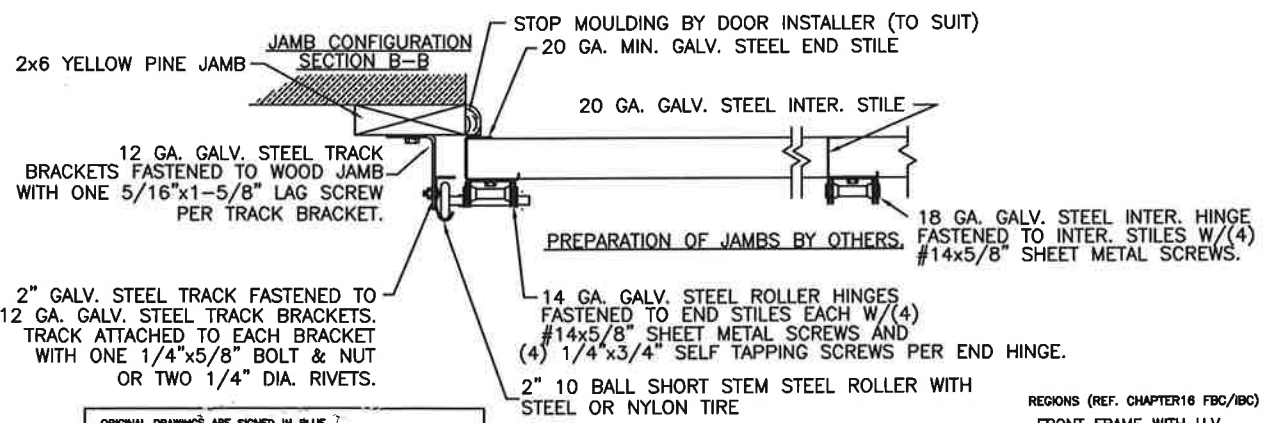

WINDOW LITE OPTION	# OF SCREWS
SHORT RECT	12
DOUBLE ARCH	14
SINGLE ARCH	15
LONG RECT	16

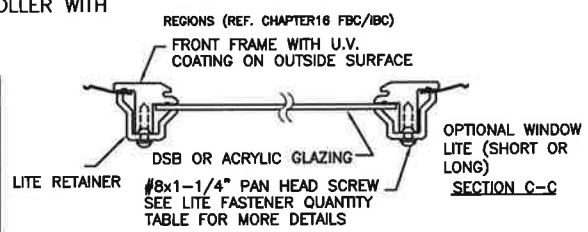

THE OPTIONAL GLAZING SHOWN ON THIS DRAWING MEETS THE WIND LOAD REQUIREMENTS OF THE FLORIDA BUILDING CODE OR INTERNATIONAL BUILDING CODE BUT DOES NOT MEET THE IMPACT RESISTANT REQUIREMENT FOR WINDBORNE DEBRIS

DESIGN LOADS: +30.0 P.S.F. & -32.0 P.S.F.
TEST LOADS: +45 P.S.F. & -48 P.S.F.

ORIGINAL DRAWINGS ARE SIGNED IN BLUE INK WITH A RAISED SEAL (EMBOSS).

Mark Westerfield
11/25/20

DESIGN ENGINEER: MARK WESTERFIELD, P.E.
FLORIDA P.E. #48495,
NC P.E. #23832,
TEXAS P.E. #91513

Clopay
CORPORATION

CLOPAY CORPORATION
8585 DUKE BLVD.
MASON, OH 45040
(513) 770-4800

Clopay Corporation All Rights Reserved.

MANUFACTURING PRODUCT CODE
PAN-2F441

DATE: 5/31/05

DRAWN BY: RJK

CHECKED BY:

WINDLOAD RATING
W5

MAX. DOOR SIZE:
9'W x 16'H

DESCRIPTION: G4S, G4SV, G4L, G4LV;
9'W +30/-32

DRAWING NUMBER:
B 103487

SHEET
2 OF 2

REV	DATE	DESCRIPTION
10	-	SEE REVISION HISTORY

NOTE: TRACK CONFIGURATION ABOVE THE DOOR OPENING DOES NOT AFFECT THE WIND LOAD RATING OF THIS DOOR.

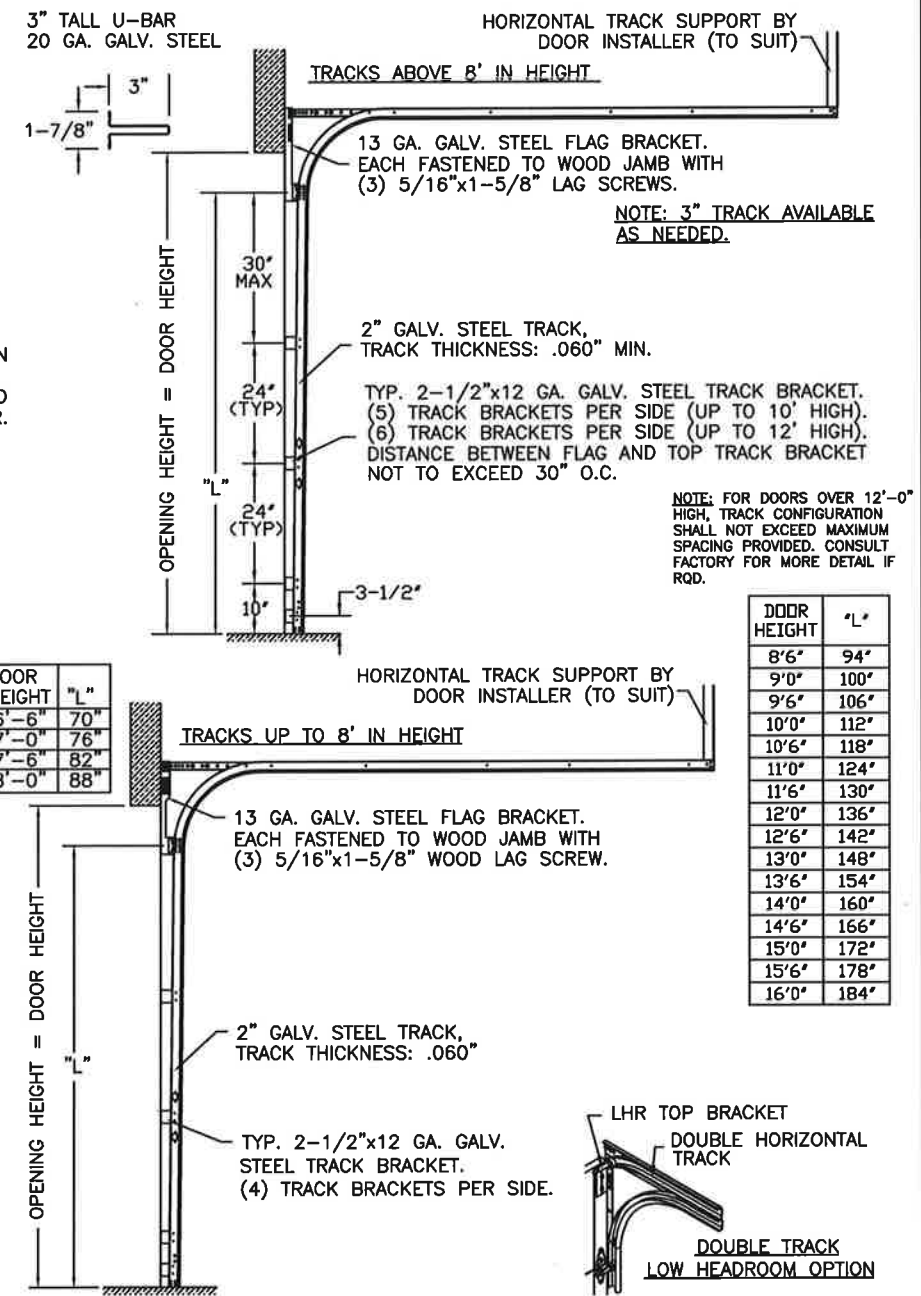

STATE OF TEXAS
11/25/20
MARK WESTERFIELD, P.E.
TEXAS P.E. No. 91513

Clopay
CORPORATION

CLOPAY CORPORATION
8585 DUKE BLVD.
MASON, OH 45040
(513) 770-4800

Clopay Corporation All Rights Reserved.

MANUFACTURING PRODUCT CODE:
PAN-2F441

DATE: 5/31/05

DRAWN BY: RJK

CHECKED BY:

WINDLOAD RATING: W5

MAX. DOOR SIZE: 9'W x 16'H

DESCRIPTION: G4S, G4SV, G4L, G4LV;
9'W +30/-32

DRAWING NUMBER: B 103487