

CLOPAY COACHMAN SERIES: CPnn, HPnn, CGnn, CXnn

HOLMES SETTLERS SERIES: SXnn

IDEAL AFFINITY SERIES: AGnn

NOTE: "nn" REPRESENTS THE ARRANGEMENT OF THE DECORATIVE OVERLAYS. THE FIRST DIGIT WILL HAVE A VALUE FROM 1 TO 3 AND THE SECOND DIGIT WILL HAVE A VALUE FROM 1 TO 5.

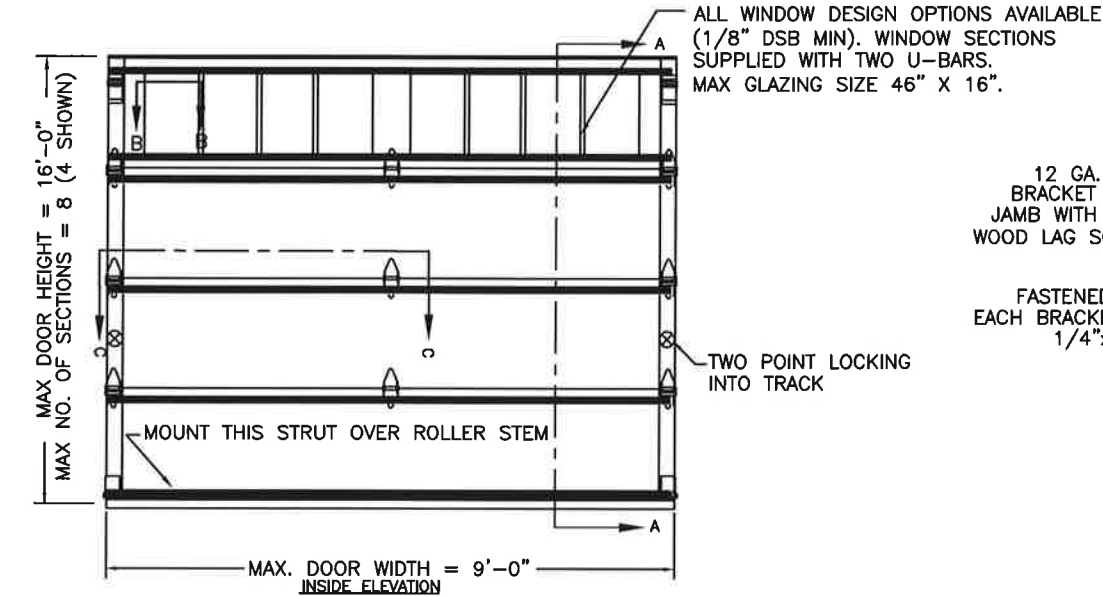

EQUIVALENT SECTION CONSTRUCTION: FOR ANY OF THE MODELS LISTED ON THIS DRAWING, THE FOLLOWING W-LEVEL DOORS USE EQUIVALENT SECTIONS (UP TO THE MAXIMUM WIDTH ALLOWED ON THIS DRAWING).

W6, W8.
 ANY OF THESE W-LEVELS MAY BE SHOWN ON THE OPTIONAL SHIPPING LABEL ON THE END STYLE.

IN THE CASE OF GYPSUM WALLBOARD LOCATED AT OR NEAR THE DOOR OPENING LOCATION THERE ARE TWO ACCEPTABLE ALTERNATIVES:

- 1) THE WALLBOARD CAN BE CUT AWAY FROM THE DOOR OPENING AND 2X6 SOUTHERN YELLOW PINE WOOD JAMBS MOUNTED DIRECTLY TO THE SUPPORTING STRUCTURE TO CREATE THE MOUNTING SURFACE. ALTERNATIVELY, THE BRACKETS MAY BE ATTACHED DIRECTLY TO THE SUPPORTING STRUCTURE. SEE DETAIL BELOW. THE CENTER OF SCREW HOLE MUST BE AT LEAST 1/2" FROM BOTH EDGES FOR A 5/16" LAG SCREW.
- 2) IF THE WALLBOARD IS NOT CUT AWAY TO EXPOSE THE UNDERLYING STRUCTURE (WOOD FRAMING MEMBERS), A 2X6 SOUTHERN YELLOW PINE WOOD BUCK OVER SHALL BE INSTALLED THE WALLBOARD FRAMING THE OPENING USING THE JAMB ATTACHMENT FASTENERS LISTED BELOW. HOWEVER, THE JAMB ATTACHMENT FASTENERS MUST BE OF A SUFFICIENT INCREASED LENGTH TO ACCOUNT FOR THE THICKNESS OF THE WALLBOARD TO ENSURE PROPER FASTENER EMBEDMENT INTO THE STRUCTURAL FRAMING MEMBERS OF THE SUPPORTING STRUCTURE.

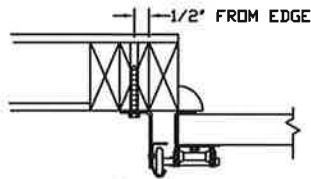

NOTE: THE DESIGN OF THE SUPPORTING STRUCTURAL ELEMENTS SHALL BE THE RESPONSIBILITY OF THE PROFESSIONAL OF RECORD FOR THE BUILDING OR STRUCTURE AND IN ACCORDANCE WITH CURRENT BUILDING CODES FOR THE LOADS LISTED ON THIS DRAWING.

PREPARATION OF JAMBS BY OTHERS.

VERTICAL JAMB ATTACHMENT (WOOD FRAME BUILDINGS):

3/8"x3" LAG SCREWS ON 24" CENTERS. 1-1/8" O.D. WASHER REQUIRED. LAG SCREWS MAY BE COUNTERSUNK (BUT NOT REQUIRED) TO PROVIDE A FLUSH MOUNTING SURFACE. HORIZONTAL JAMBS DO NOT TRANSFER LOAD.

VERTICAL JAMB ATTACHMENT (C-90 BLOCK OR 2,000 PSI MIN. CONCRETE COLUMN):

3/8"x3" SLEEVE ANCHOR BOLTS ON 22" CENTERS (2,000 PSI MIN. CONCRETE). WASHERS INCLUDED WITH SLEEVE ANCHORS.

OR
 1/4"x3" TAPCON SCREWS ON 22" CENTERS (2,000 PSI MIN. CONCRETE) OR 22" CENTERS (C-90 BLOCK), 1" O.D. WASHERS REQUIRED WITH TAPCONS. ANCHORS MAY BE COUNTERSUNK (BUT NOT REQUIRED) TO PROVIDE A FLUSH MOUNTING SURFACE. HORIZONTAL JAMBS DO NOT TRANSFER LOAD.

OTHER JAMB CONFIGURATIONS: REFER TO DASMA TDS-161. A LICENSED DESIGN PROFESSIONAL MAY ALSO BE EMPLOYED TO APPROVE ALTERNATE FASTENERS AND/OR JAMB CONFIGURATIONS.

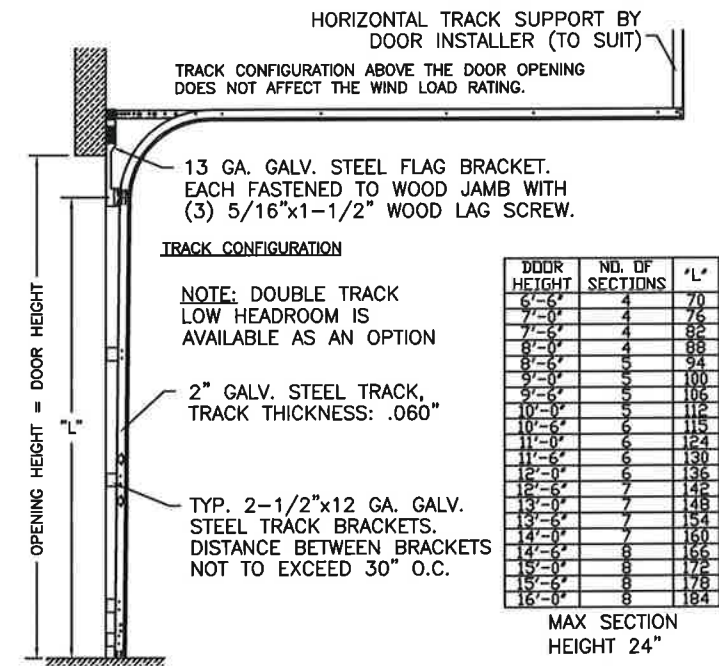
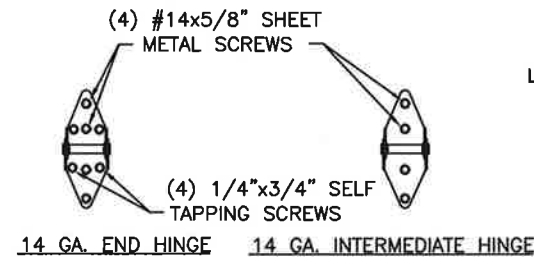
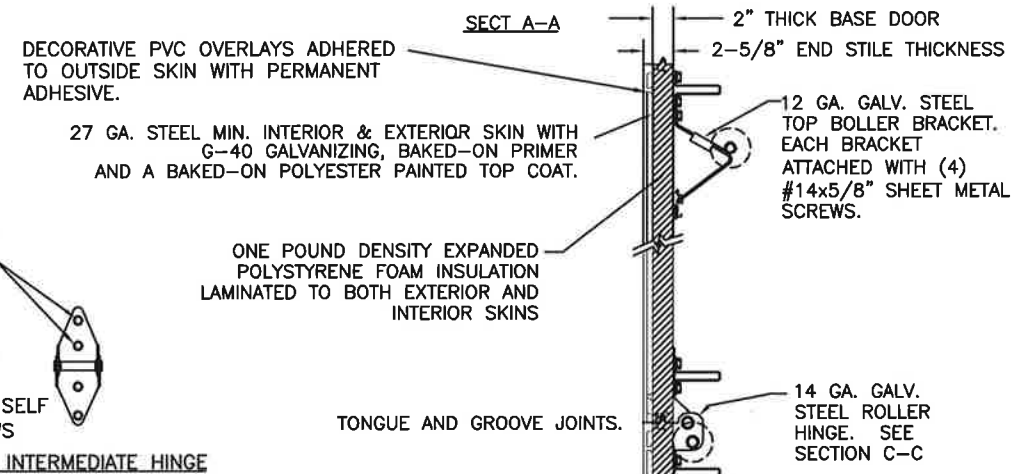
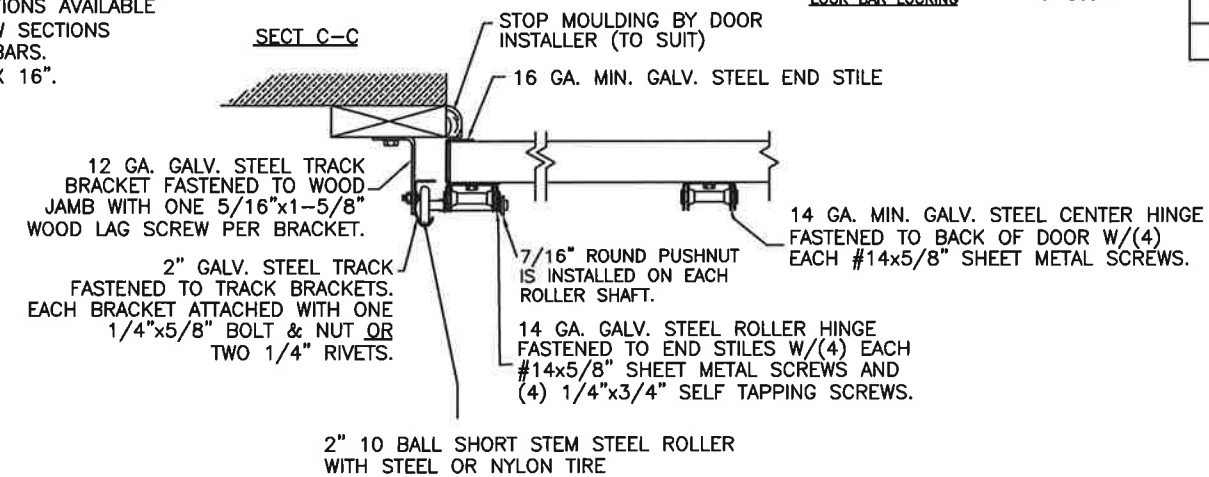
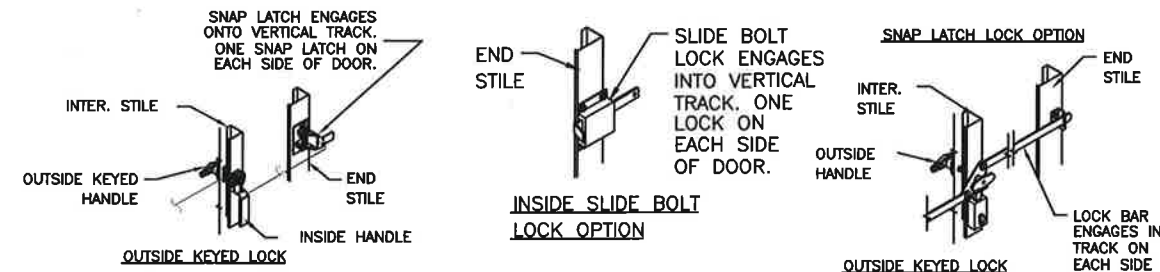

THE OPTIONAL GLAZING SHOWN ON THIS DRAWING MEETS THE WIND LOAD REQUIREMENTS OF THE FLORIDA BUILDING CODE OR INTERNATIONAL BUILDING CODE BUT DOES NOT MEET THE IMPACT RESISTANT REQUIREMENT FOR WINDBORNE DEBRIS REGIONS (REF. CHAPTER 16 FBC/IBC)

DESIGN LOADS: +38.0 P.S.F. & -42.0 P.S.F.
 TEST LOADS: +57.0 P.S.F. & -63.0 P.S.F.

ORIGINAL DRAWINGS ARE SIGNED IN BLUE INK WITH A RAISED SEAL (EMBOSS).

 DESIGN ENGINEER; MARK WESTERFIELD, P.E.
 FLORIDA P.E. #48495,
 NC P.E. #23832,
 TEXAS P.E. #91513

Clopay
 CORPORATION

CLOPAY CORPORATION
 8585 DUKE BOULEVARD
 CINCINNATI, OH 45040
 (513) 770-4800
 Clopay Corporation All Rights Reserved.

REV	DATE	DESCRIPTION
06	05/2005	UPDATED CODE REFERENCE
07	06/2005	ADDED ROLLER OPTION
08	02/2006	ADDED CG, CX, AG, SX MODELS
09	08/2008	ADDED IMPACT RESISTANT TEXT AND A/B DRAWING NUMBER
10	10/21/08	ADDED PUSHNUTS
11	02/10/12	UPDATED WINDCODE CHART
12	08/21/12	REVISED FOR TDI
13	06/05/13	ADDED MAX GLAZING SIZE.
14	08/2016	REMOVED WIND SPEED TABLE.
15	11/23/20	UPDATED TITLE BLOCK AND ADDED COMPLIANCE STATEMENT.

THIS PRODUCT COMPLIES WITH THE 2018 IBC/IRC.