

REV	DESCRIPTION OF REVISIONS	DATE	BY

MAX SIZE 9'2" x 24'

DESIGN LOADS +32.7 PSF -38.4 PSF

TEST LOADS +49.1 PSF -57.6 PSF

Thomas L. Shelmerdine, PE (TX PE #85829) Structural Solutions, PA (TX Firm #04063)

STATE OF TEXAS  
THOMAS L. SHELMERDINE  
85829  
LICENSED PROFESSIONAL ENGINEER

TX

5921-G.W. Friendly Ave., Greensboro, NC 27410

THE METHOD OF TESTING WAS IN SUBSTANTIAL CONFORMANCE WITH THE PROCEDURES DESCRIBED IN DASMA 108. THE PRESSURES SHOWN ON THE DRAWINGS WERE CALCULATED USING ASCE 7-98/02/05 WITH THE FOLLOWING PARAMETERS (5 FEET OF DOOR WIDTH IN END ZONE, ROOF SLOPE 10' OR LESS, AND I=1.0):

WIND SPEED (MPH)	151	137	130	124	119
EXPOSURE LEVEL	B	C	C	D	D
MEAN ROOF HEIGHT	30'	15'	25'	15'	25'

MODEL 2000 AMARR 2002, 2012, 2022

SIZE	DRAWN BY	RLR	DATE	1/19/17	DRAWING NUMBER
B	CHECKED BY	RLR	DATE	1/19/17	IBC-2009-150-11

ENTREMATIAC  
165 CARRIAGE COURT WINSTON-SALEM, N.C. 27105

SHEET 1 OF 4

## TRACK CONNECTION DIRECTLY TO STRUCTURE OPTIONS

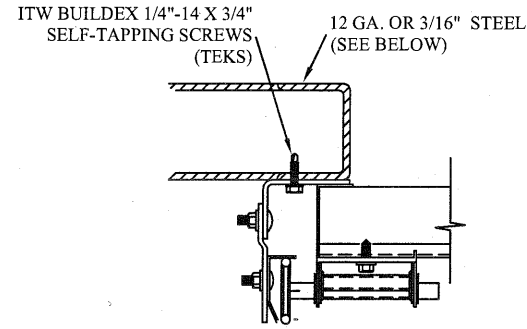

CLIP STYLE REVERSE ANGLE MOUNT SHOWN  
BRACKET, CONTINUOUS AND TAPERED ANGLE  
MOUNT AVAILABLE

12 GA. STEEL FRAMING  
232 LBS./SCREW ALLOWABLE LOAD - 6" FROM ENDS  
AND 18" O.C.  
REFER TO NOTES: 1, 2 AND 5

3/16" STEEL FRAMING  
569 LBS./SCREW ALLOWABLE LOAD - 6" FROM ENDS  
AND 24" O.C.  
REFER TO NOTES: 1, 2 AND 5

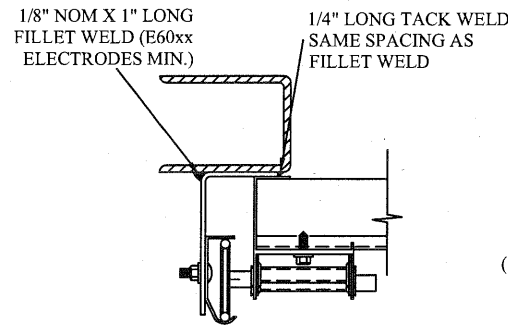

REVERSE ANGLE MOUNT SHOWN  
BRACKET, CONTINUOUS AND TAPERED  
ANGLE MOUNT AVAILABLE

STEEL FRAMING 12GA OR BETTER  
1590 LBS./IN. ALLOWABLE LOAD - 6"  
FROM ENDS AND 24" O.C.  
REFER TO NOTES: 1, 2, 5, 6, 7, 8 AND 9

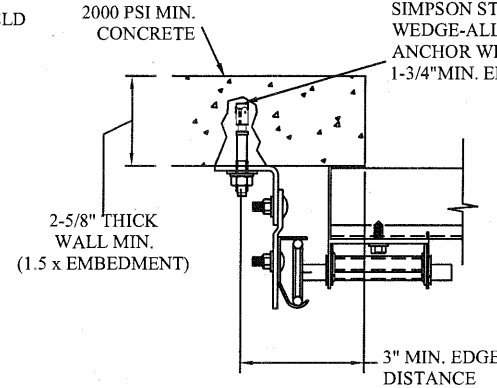

CLIP STYLE CONTINUOUS ANGLE MOUNT SHOWN  
BRACKET, REVERSE AND TAPERED ANGLE MOUNT  
AVAILABLE

2000 PSI CONCRETE OR GREATER  
351 LBS./EXPANSION ANCHOR ALLOWABLE LOAD - 6"  
FROM ENDS AND 24" O.C.  
REFER TO NOTES: 1, 2, 3, 4 AND 5

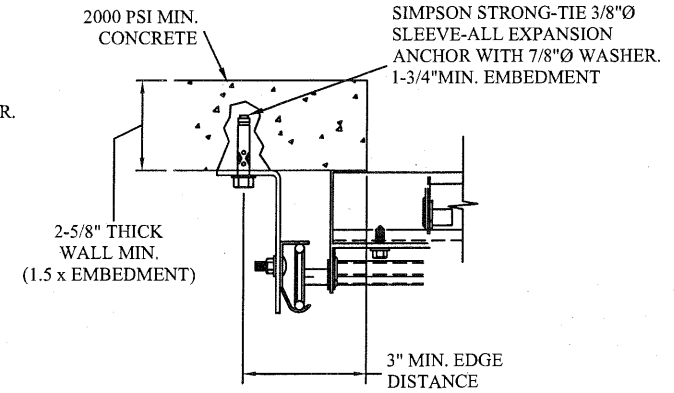

CONTINUOUS ANGLE MOUNT SHOWN  
BRACKET, CONTINUOUS AND TAPERED ANGLE  
MOUNT AVAILABLE

2000 PSI CONCRETE OR GREATER  
336 LBS./EXPANSION ANCHOR ALLOWABLE LOAD - 6"  
FROM ENDS AND 24" O.C.  
REFER TO NOTES: 1, 2, 3, 4 AND 5

### SPECIFICATIONS AND NOTES

- ALL THE LOAD FROM THE DOOR IS TRANSFERRED TO THE VERTICAL TRACK, FROM THE TRACK THE LOAD IS TRANSFERRED TO THE VERTICAL JAMBS. THE HORIZONTAL JAMB OR HEADER RECEIVES NO PORTION OF THE LOAD TRANSFERRED FROM THE DOOR.
- EACH VERTICAL JAMBS RECEIVES MAXIMUM DESIGN LOADS OF: +149.9 LBS/FT AND -176.0 LBS/FT
- DOOR AND HARDWARE WILL BE DESIGNED, MANUFACTURED AND INSTALLED WITH STANDARDS AS SET FORTH BY DASMA.
- DOOR SECTIONS SHALL BE 20 GA. (.033) MIN. EXTERIOR SKIN ROLLED FORMED, GALVANIZATION W/ BAKED ON POLYESTER FINISH
- DOORS UP TO 24' HIGH USE (1) 2" 20GA STRUT PER INTERMEDIATE SECTION AND (2) 2" 20GA STRUTS ON BOTTOM SECTION.
- SUPPORTING STRUCTURAL ELEMENTS SHALL BE DESIGNED BY A REGISTERED PROFESSIONAL ENGINEER FOR WIND LOADS INDICATED ON THIS DRAWING IN ADDITION TO OTHER LOADINGS.

## WOOD JAMB ATTACHMENT TO STRUCTURE (OPTIONAL)

2 X 6 VERTICAL JAMB ATTACHMENT TO WOOD FRAME STRUCTURE  
5/16" X 3" LAG SCREWS STARTING 6" FROM ENDS THEN 24" O.C. (1 1/2" EMBEDMENT)

2 X 6 VERTICAL JAMB ATTACHMENT TO 2,000 PSI CONCRETE  
HILTI KWIK BOLT 3/8" X 4" STARTING 6" FROM ENDS THEN 24" O.C. (2 1/2" EMBEDMENT)  
HILTI SLEEVE ANCHOR 3/8" X 2-3/4" STARTING 6" FROM ENDS THEN 24" O.C. (1 1/4" EMBEDMENT)  
ITW/RAMSET REDHEAD (TRU-BOLT) 3/8" X 4" STARTING 6" FROM ENDS THEN 24" O.C. (2 1/2" EMBEDMENT)

2 X 6 VERTICAL JAMB ATTACHMENT TO HOLLOW C-90 BLOCK  
SIMPSON 1/4" X 3" TITEN SCREWS STARTING 6" FROM ENDS, USE PAIRS OF FASTENERS (3" APART) AT 24" O.C. (1 1/2" EMBEDMENT)  
HILTI 1/4" X 2-3/4" KWIK-CON II+ SCREWS STARTING 6" FROM ENDS, USE PAIRS OF FASTENERS (3" APART) AT 24" O.C. (1 1/4" EMBEDMENT)

2 X 6 VERTICAL JAMB ATTACHMENT TO GROUTED C-90 BLOCK (2000 PSI GROUT)  
HILTI SLEEVE ANCHOR 3/8" X 2-3/4" STARTING 6" FROM ENDS THEN 24" O.C. (1 1/4" EMBEDMENT)  
(OR, USE FASTENERS FOR HOLLOW C-90 BLOCK)

\*LAGS AND BOLTS CAN BE COUNTERSUNK TO PROVIDE A FLUSH MOUNTING SURFACE.  
\*PREPARATION OF WOOD JAMBS BY OTHERS

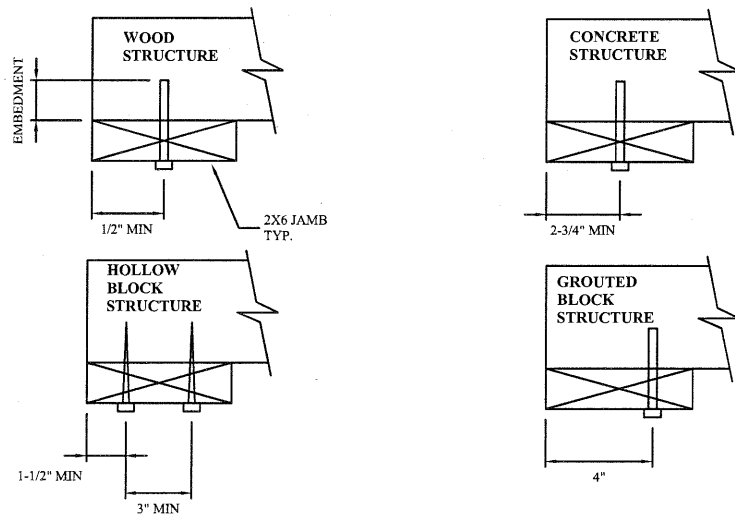

### NOTES:

- ANCHORS TO BE EVENLY SPACED BETWEEN THE HEADER AND FLOOR.
- FIRST (BOTTOM) ANCHOR STARTING AT NO MORE THAN HALF OF THE MAXIMUM ON-CENTER DISTANCE. HIGHEST ANCHOR INSTALLED AT LEAST AS HIGH AS THE DOOR OPENING.
- MIN. EDGE DISTANCE OF 3" REQUIRED.
- USE WASHERS PROVIDED BY THE ANCHOR MANUFACTURER.
- SUPPORTING STRUCTURAL ELEMENTS SHALL BE DESIGNED BY A REGISTERED PROFESSIONAL ENGINEER FOR WIND LOADS IN ADDITION TO OTHER LOADS.
- MOST GARAGE DOOR TRACK IS GALVANIZED STEEL. USE ALL NECESSARY PRECAUTIONS WHEN WELDING GALVANIZED STEEL.
- ALL WELDS SHOULD BE PERFORMED BY A CERTIFIED WELDER OR INSPECTED BY A CERTIFIED WELDING INSPECTOR TO VERIFY THE INTEGRITY OF THE WELD.
- FILLET WELDS TO HAVE A STRAIGHT OR CONVEX FACE SURFACE.
- TACK WELD TOE OF ANGLE AT SAME SPACING TO PREVENT ROTATION OF TRACK ANGLE.

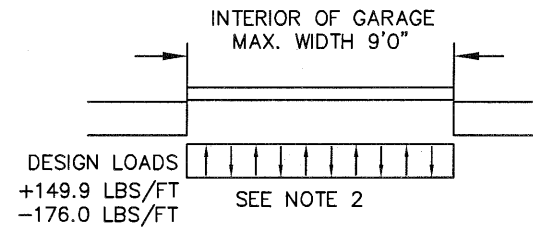

## TRACK CONNECTION TO WOOD JAMB OPTIONS

FOR LAG SCREWS & BRACKET SPACING SEE PAGE 4 FOR TRACK CONFIGURATION DETAIL

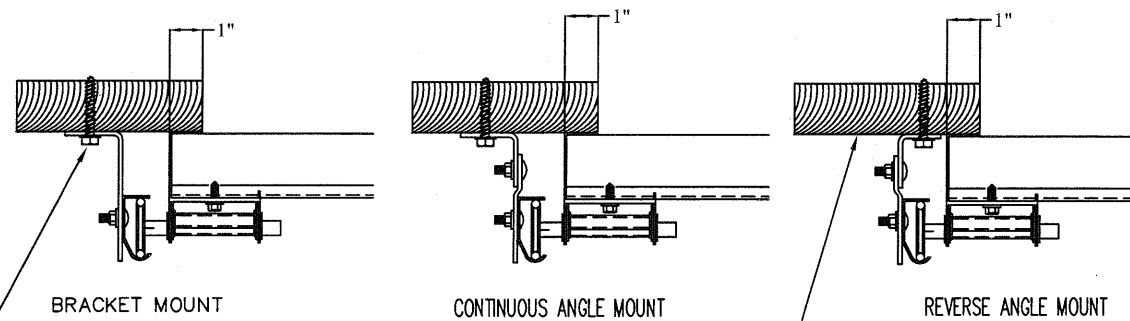

5/16" x 1 5/8" LAG SCREW (1) PER  
JAMB BRACKET (1-1/2" EMBEDMENT  
MINIMUM) (TYP.)

2x6 WOOD JAMB SYP  
(NO.2) OR BETTER (TYP.)

REV	DESCRIPTION OF REVISIONS	DATE	BY
	MAX SIZE 9'2 x 24'		
	DESIGN LOADS +32.7 PSF -38.4 PSF		
	TEST LOADS +49.1 PSF -57.6 PSF		
MODEL 2000 AMARR 2002, 2012, 2022			
SIZE	DRAWN BY RLR	DATE 1/19/17	DRAWING NUMBER
B	CHECKED BY RLR	DATE 1/19/17	IBC-2009-150-11
ENTREMATIC			SHEET 2 OF 4
165 CARRIAGE COURT WINSTON-SALEM, N.C. 27105			

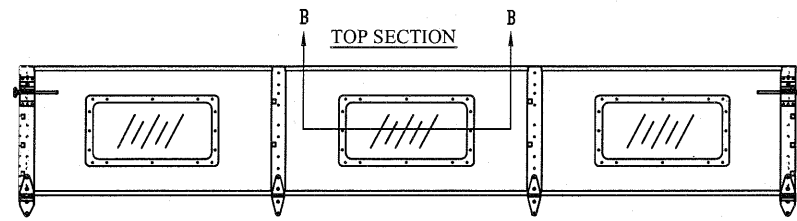

TOP SECTION

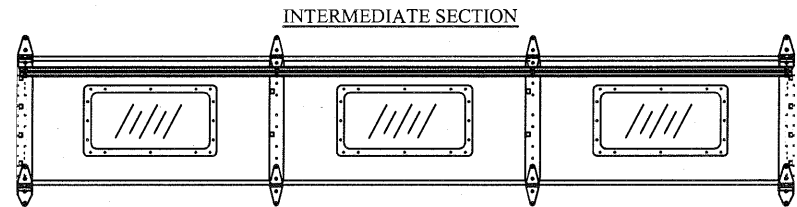

INTERMEDIATE SECTION

OPTIONAL GLAZED SECTION W/ 24" X 12" WINDOWS AND STRUT LAYOUT  
N.T.S.

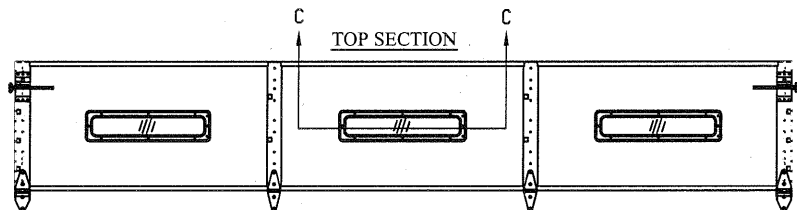

TOP SECTION

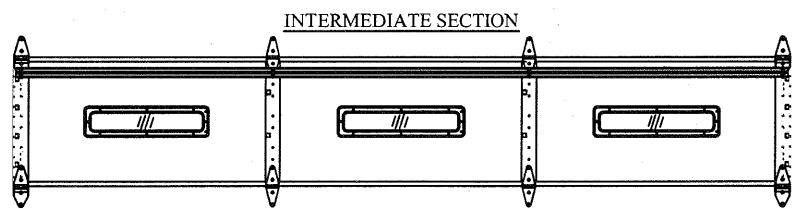

INTERMEDIATE SECTION

OPTIONAL GLAZED SECTION W/ 24" X 6" WINDOWS AND STRUT LAYOUT  
N.T.S.

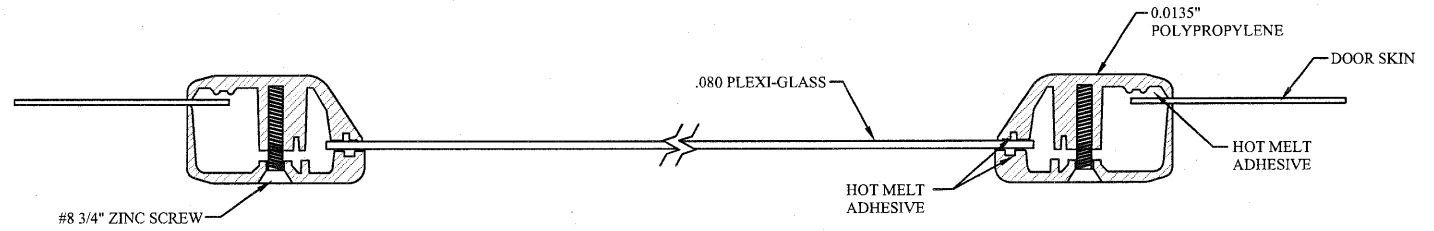

SECTION B-B 24" X 12" WINDOW DETAIL W/ .080 PLEXI-GLASS  
N.T.S.

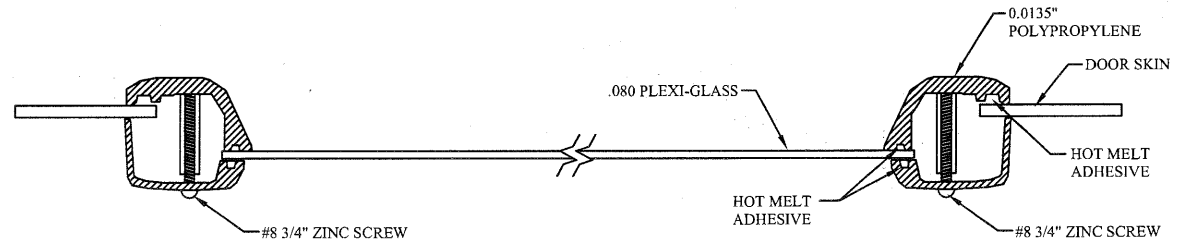

SECTION C-C 24" X 6" WINDOW DETAIL W/ .080 PLEXI-GLASS  
N.T.S. (ALSO AVAILABLE WITH 1/8" DSB GLASS)

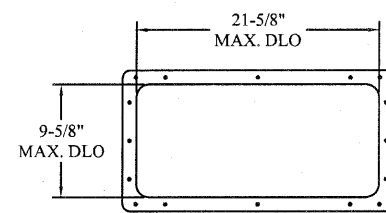

24" X 12" DAY LIGHT OPENING AND FASTENER DETAIL  
N.T.S.

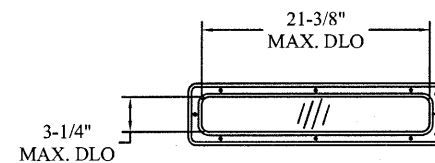

24" X 6" DAY LIGHT OPENING AND FASTENER DETAIL  
N.T.S.

REV	DESCRIPTION OF REVISIONS	DATE	BY												
	MAX SIZE 9'2" x 24'  DESIGN LOADS +32.7 PSF -38.4 PSF  TEST LOADS +49.1 PSF -57.6 PSF														
	Thomas L. Shelmerdine, PE (TX PE #85829) Structural Solutions, PA (TX Firm #004063)														
	TX 														
	MODEL 2000 AMARR 2002, 2012, 2022														
	<table border="1"> <tr> <td>SIZE</td> <td>DRAWN BY</td> <td>RLR</td> <td>DATE</td> <td>1/19/17</td> <td>DRAWING NUMBER</td> </tr> <tr> <td>B</td> <td>CHECKED BY</td> <td>RLR</td> <td>DATE</td> <td>1/19/17</td> <td>IBC-2009-150-11</td> </tr> </table>	SIZE	DRAWN BY	RLR	DATE	1/19/17	DRAWING NUMBER	B	CHECKED BY	RLR	DATE	1/19/17	IBC-2009-150-11		
SIZE	DRAWN BY	RLR	DATE	1/19/17	DRAWING NUMBER										
B	CHECKED BY	RLR	DATE	1/19/17	IBC-2009-150-11										
	ENTREMATIC 165 CARRIAGE COURT WINSTON-SALEM, N.C. 27105														
	SHEET 3 OF 4														

5921-G W. Friendly Ave., Greensboro, NC 27410

TABLE 1

Section	Center Stile Locations		Max Design Loads Allowed		
	Width (ft)	1st (in)	2nd (in)	Positive (PSF)	Negative (PSF)
6'0	36"			33.1	38.9
6'2	37"			32.2	37.8
6'4	23"	53"		45.0	52.8
6'6	24"	54"		44.2	51.9
6'8	25"	55"		43.4	50.9
6'10	26"	56"		42.6	50.0
7'0	27"	57"		41.8	49.1
7'2	28"	58"		41.1	48.3
7'4	27"	61"		39.1	45.9
7'6	28"	62"		38.5	45.2
7'8	29"	63"		37.8	44.4
7'10	30"	64"		37.2	43.8
8'0	31"	65"		36.7	43.1
8'2	32"	66"		36.1	42.4
8'4	32"	68"		35.1	41.2
8'6	33"	69"		34.5	40.6
8'8	34"	70"		34.1	40.0
8'10	35"	71"		33.6	39.4
9'0	36"	72"		33.1	38.9
9'2	37"	73"		32.7	38.4

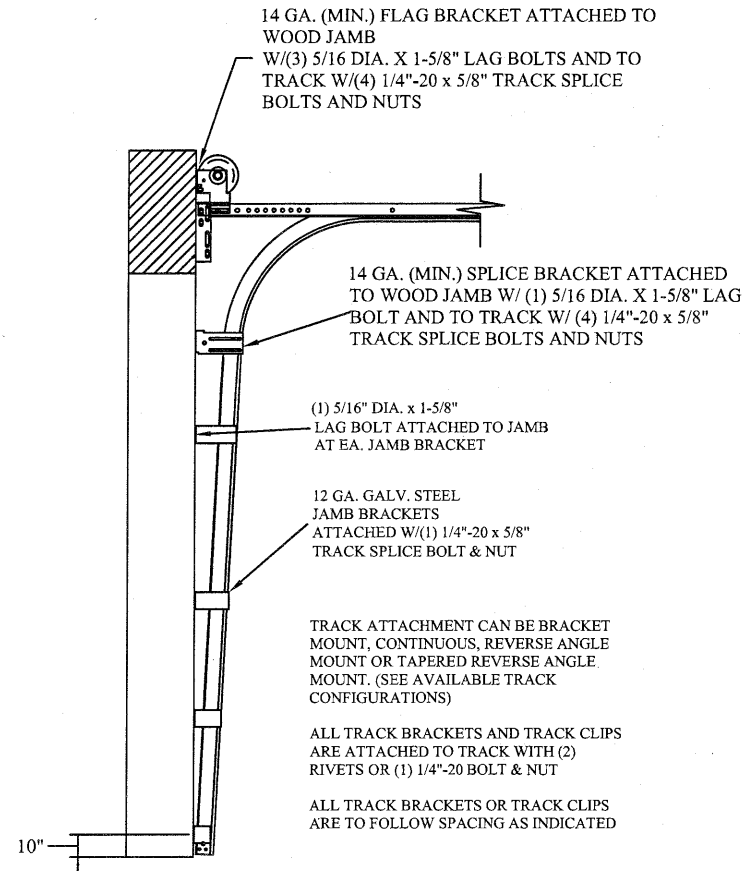

TRACK CONFIGURATION FOR UP TO 24' TALL DOORS  
SEE TABLE 2

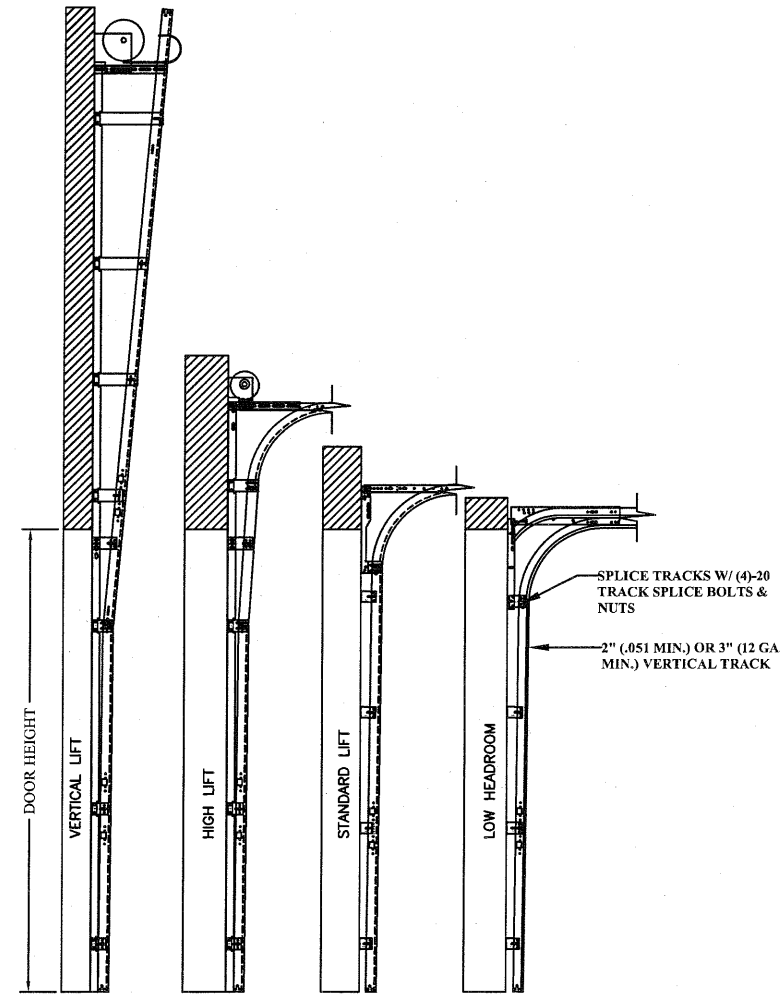

AVAILABLE TRACK CONFIGURATIONS  
N.T.S.

TABLE 2

DOOR HEIGHT	TRACK ATTACHMENT																					TYPICAL SPLICE			
	A	B	C	D	E	F	G	H	I	J	K	L	M	N	O	P	Q	R	S	T	U		V	W	
7' 0"	10"	22"	34"	46"	58"																			76"	
7' 6"	10"	22"	34"	46"	58"																				82"
8' 0"	10"	22"	34"	46"	58"	70"																			88"
8' 6"	10"	22"	34"	46"	58"	70"	82"																		94"
9' 0"	10"	22"	34"	46"	58"	70"	82"																		100"
9' 6"	10"	22"	34"	46"	58"	70"	82"	94"																	106"
10' 0"	10"	22"	34"	46"	58"	70"	82"	94"	106"																112"
11' 0"	10"	22"	34"	46"	58"	70"	82"	94"	106"	118"															124"
12' 0"	10"	22"	34"	46"	58"	70"	82"	94"	106"	118"	130"														136"
13' 0"	10"	22"	34"	46"	58"	70"	82"	94"	106"	118"	130"	142"													148"
14' 0"	10"	22"	34"	46"	58"	70"	82"	94"	106"	118"	130"	142"	154"												160"
15' 0"	10"	22"	34"	46"	58"	70"	82"	94"	106"	118"	130"	142"	154"	166"											172"
16' 0"	10"	22"	34"	46"	58"	70"	82"	94"	106"	118"	130"	142"	154"	166"	178"										184"
17' 0"	10"	22"	34"	46"	58"	70"	82"	94"	106"	118"	130"	142"	154"	166"	178"	190"									196"
18' 0"	10"	22"	34"	46"	58"	70"	82"	94"	106"	118"	130"	142"	154"	166"	178"	190"	202"								208"
19' 0"	10"	22"	34"	46"	58"	70"	82"	94"	106"	118"	130"	142"	154"	166"	178"	190"	202"	214"							220"
20' 0"	10"	22"	34"	46"	58"	70"	82"	94"	106"	118"	130"	142"	154"	166"	178"	190"	202"	214"	226"						232"
21' 0"	10"	22"	34"	46"	58"	70"	82"	94"	106"	118"	130"	142"	154"	166"	178"	190"	202"	214"	226"	238"					244"
22' 0"	10"	22"	34"	46"	58"	70"	82"	94"	106"	118"	130"	142"	154"	166"	178"	190"	202"	214"	226"	238"	250"				256"
23' 0"	10"	22"	34"	46"	58"	70"	82"	94"	106"	118"	130"	142"	154"	166"	178"	190"	202"	214"	226"	238"	250"	262"			268"
24' 0"	10"	22"	34"	46"	58"	70"	82"	94"	106"	118"	130"	142"	154"	166"	178"	190"	202"	214"	226"	238"	250"	262"	274"		280"

ALL TRACK ATTACHMENTS +/- 2" ALLOWED USING SYP OR SPF NO.2 OR BETTER ONLY.

REV	DESCRIPTION OF REVISIONS	DATE	BY

MAX SIZE  
9'2" x 24'

DESIGN LOADS  
+32.7 PSF  
-38.4 PSF

TEST LOADS  
+49.1 PSF  
-57.6 PSF

TX

**Amarr**  
ENTREMATIC

5921-G W. Friendly Ave., Greensboro, NC 27410

MODEL 2000 AMARR 2002, 2012, 2022

SIZE	DRAWN BY RLR	DATE 1/19/17	DRAWING NUMBER
B	CHECKED BY RLR	DATE 1/19/17	IBC-2009-150-11
ENTREMATIC 165 CARRIAGE COURT WINSTON-SALEM, N.C. 27105			SHEET 4 OF 4