

NOTE: Track configuration above the door opening does not affect the wind load rating of the door.

Door Height 8'-0" Shown
See chart below for other door heights

Door Width 10'-2" Shown
See chart below for other door widths

SEE SHEET 3 OF 4 FOR GLAZING DETAIL AND LITE OPTIONS.

Slide Lock or Lock Bars Detail G (sheet 2 of 4)
Manual door locks are required unless an automatic operator is installed.

Top Bracket Detail A (sheet 2 of 4)

Strut & Strut Attachment Detail J (sheet 2 of 4)

Flag Bracket Detail H (sheet 2 of 4)

Bottom Bracket Detail C (sheet 2 of 4) End Hinge Detail B (sheet 2 of 4)

Strut & Strut Attachment Detail E (sheet 2 of 4) Intermediate Hinge Detail D (sheet 2 of 4)

Jamb Bracket Detail F (sheet 2 of 4)

This product has been evaluated per ANSI/DASMA 108 for static air pressure.

Jamb bracket quantities shown are for use with grade 2 or better southern pine jambs. Supporting structural elements are to be designed by a registered professional engineer for specific wind loads.

Door Widths Up To	Design Pressures		End Stile	Model Number						
	+ psf	- psf		Minimum Center Stiles		Minimum Center Hinges		Minimum Center Stiles		
8'-2"	26.5	-30.0	Single	1	1	1	1	1	1	1
9'-2"	23.6	-26.7	Single	1	1	1	1	1	1	1
10'-2"	21.3	-24.1	Single	2	2	1	1	2	2	2

This product is designed and sold by PSF. The AHJ or Engineer of Record is responsible for determining the PSF required for any given site.

Door Height	Total No. of Sections	Total # of Struts (When lite section is the top section. If not see the notice at the right)	Jamb Brkts/Side
6'-0"	3	3	2
6'-0"	4	4	2
6'-3"	4	4	2
6'-6"	4	4	3
6'-9"	4	4	3
7'-0"	4	4	3
7'-3"	4	4	3
7'-6"	4	4	3
7'-6"	5	5	3
7'-9"	4	4	3
7'-9"	5	5	3
8'-0"	4	4	3
8'-0"	5	5	3

NOTICE:

These drawings are a supplement to the installation instructions for a standard door and only covers those procedures that vary from standard door installation. If these specific procedures are not followed, the door may not perform as designed.

NOTICE:

The lite section of this door may be replaced with a section with another lite style or a solid section. In either case the strut and stile configuration should remain the same.

NOTICE:

Only one lite section per door is permitted. The lite section can be used anywhere except for the bottom section. If the lite section is not the top section then the struts must be located as shown in the STRUT CONFIGURATION on sheet 3 of 4.

John E. Scates, P.E.
2560 King Arthur Blvd. Ste 124-54
Lewisville, Texas 75056
Texas P.E. 56308/F2203

COMPLIES WITH IBC/IRC 2018 Professional Engineer seal provided only for verification of wind load construction details.

Maximum section height is 24 in.

Maximum door height is 20 ft.

All doors, even those above the tested height, are available with jamb brackets or commercial full angle. The maximum spacing of the jamb brackets/track clips should be maintained.

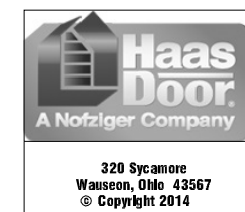

DESCRIPTION: 10' 2" PAN 2000 SERIES W/LITES WIND LOAD SECTIONAL DOOR DESIGN PRESSURE +21.3/-24.1 PSF			
DRAWING NO.: WLT-2000-0122-08-21-24L	REV.: A		
DRAWN BY: MVS	DATE DRAWN: 11/6/18	REV. DATE: 3/8/22	
MODEL(S): See Sheet 3	SHEET: 1 OF 4		

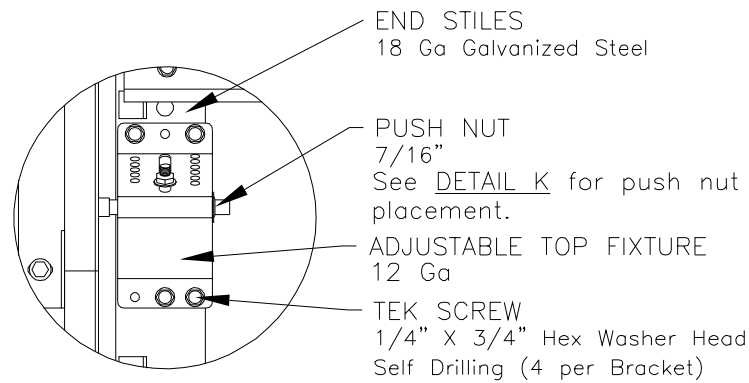

DETAIL A

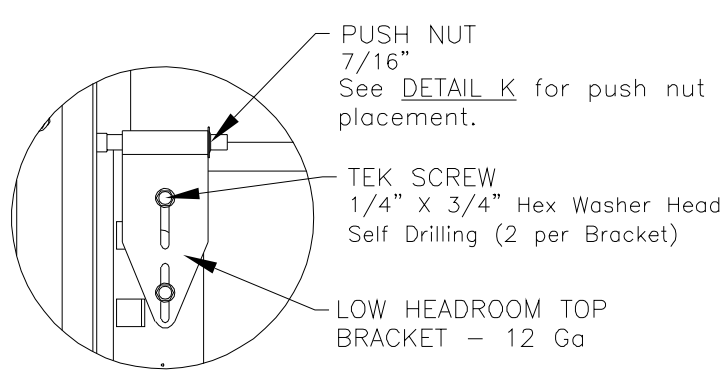

LOW HEADROOM TOP BRACKET

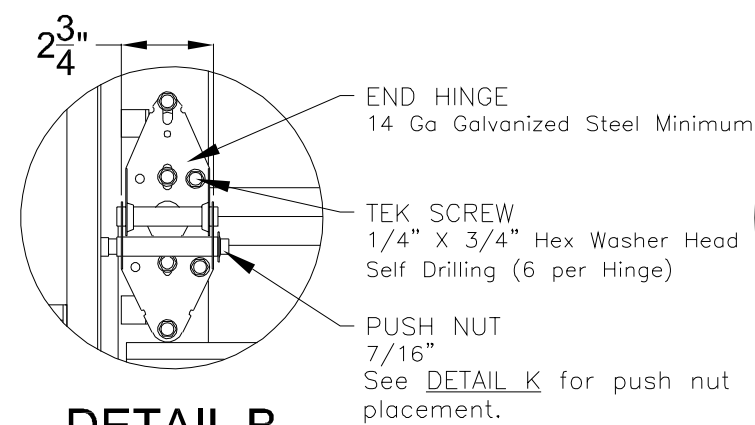

DETAIL B

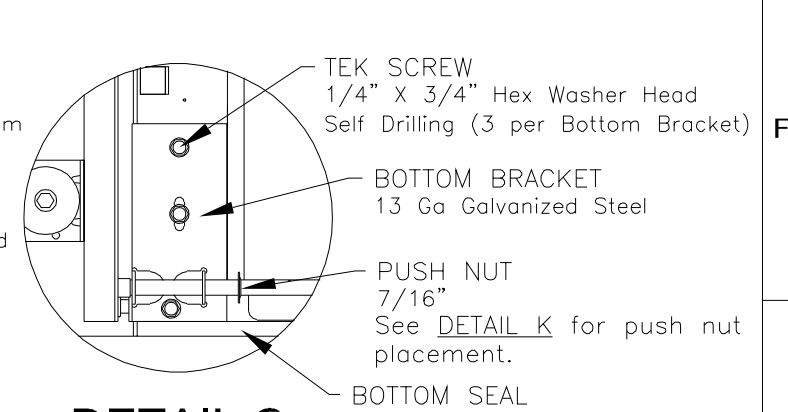

DETAIL C

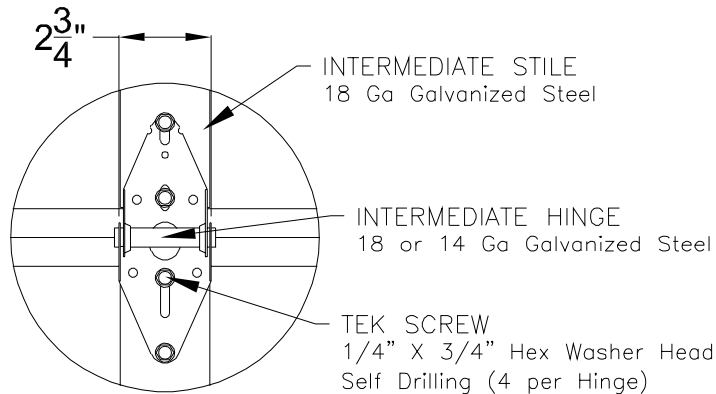

DETAIL D

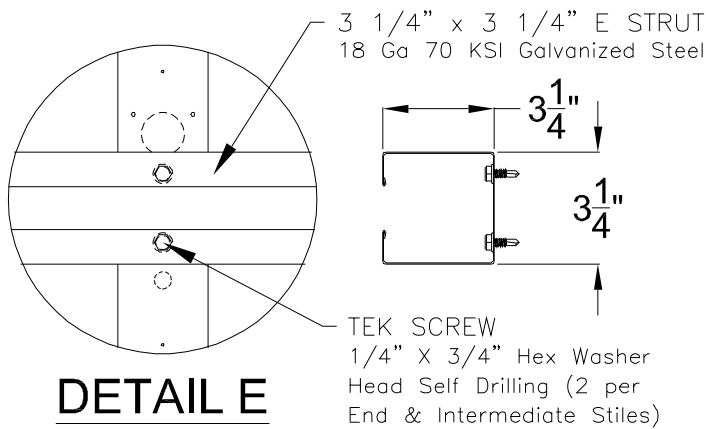

DETAIL E

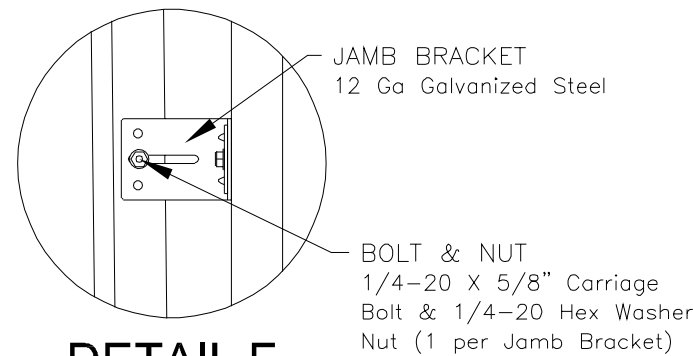

DETAIL F

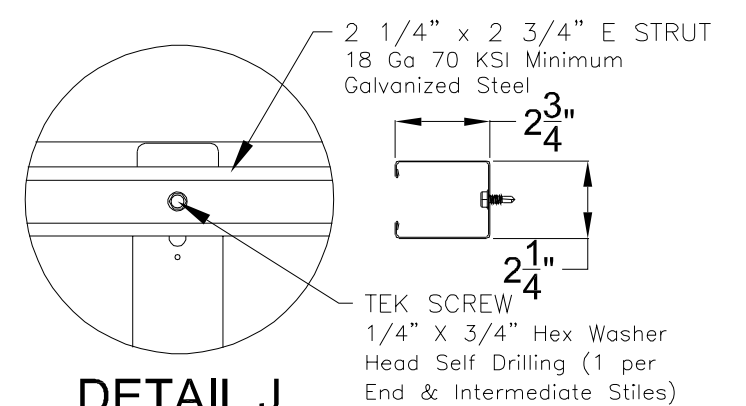

DETAIL J

NOTE: Details on some views omitted for clarity. Double end stiles and end hardware may be provided on wider or heavier doors.

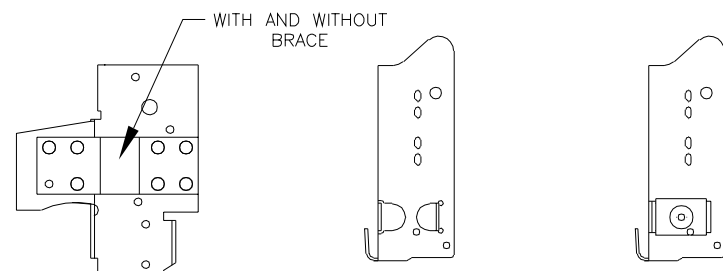

RESIDENTIAL & LIGHT COMMERCIAL For Low Headroom With 2" Track and Single End Stiles

COMMERCIAL For Standard, High & Vertical Lift With 2" Track and Single End Stiles

COMMERCIAL For Standard, High & Vertical Lift With 3" Track and Single End Stiles

ALTERNATE BOTTOM BRACKETS

NOTE: The bottom bracket tested (shown in DETAIL C) is the lightest bracket available.

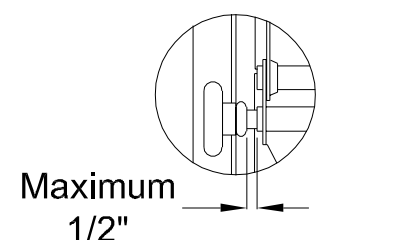

DETAIL K

There should be a space of maximum 1/2" between the roller hub and the outside edge of the roller holder which is set by the push nut.

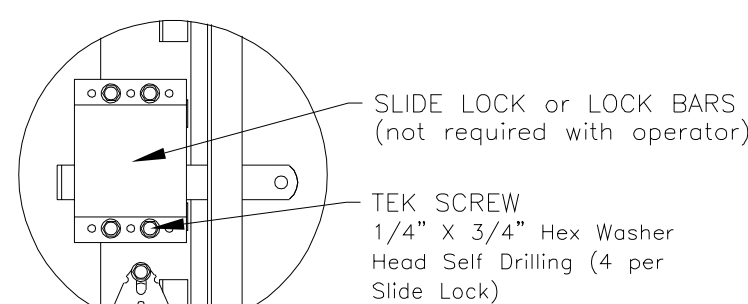

DETAIL G

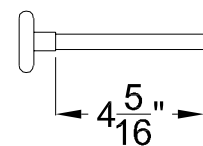

ROLLER

2" Diameter Nominal Eleven Ball Nylon or Ten Ball Steel with a Minimum Workable Shaft Length Shown.

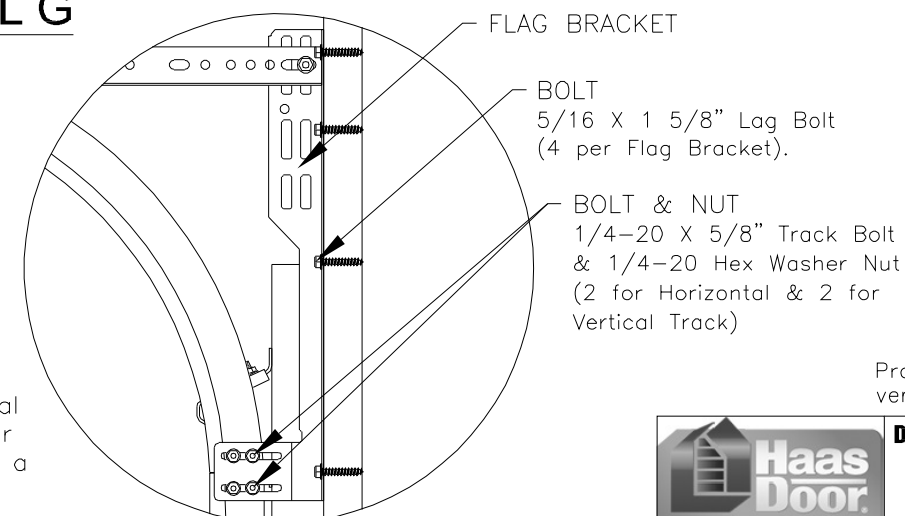

DETAIL H

John E. Scates, P.E.
2560 King Arthur Blvd. Ste 124-54
Lewisville, Texas 75056
Texas P.E. 56308/F2203

Professional Engineer seal provided only for verification of wind load construction details.

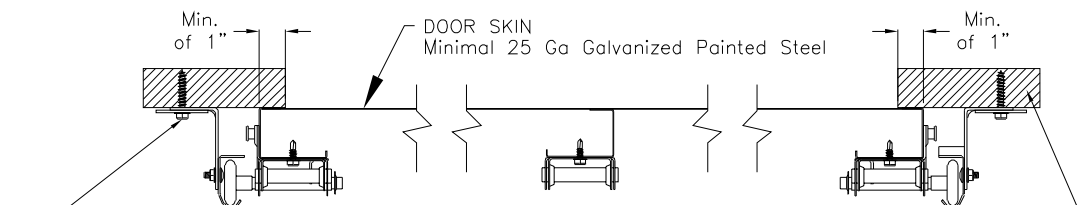

BOLT & WASHER
5/16" X 1 5/8" Lag Bolt & 2" O.D. x 7/16" I.D. Flat Washer
NOTE: Jamb bracket must be in direct contact with the 2x6 (No drywall allowed).
NOTE: The flat washer is not required for angle mount.

VERTICAL TRACK - 2" Nominal
13 Ga Galvanized Steel tested. 3" Nominal 13 Ga is also approved as an alternate.

The vertical wood jamb fasteners may be counter sunk to provide a flat mounting surface. See jamb attachment details on sheet 3 for attaching jambs to the structure.

<p>320 Sycamore Wauseon, Ohio 43567 © Copyright 2014</p>	<p>DESCRIPTION: 10' 2" PAN 2000 SERIES W/LITES WIND LOAD SECTIONAL DOOR DESIGN PRESSURE +21.3/-24.1 PSF</p>	
	<p>DRAWING NO.: WLT-2000-0122-08-21-24L</p>	<p>REV.: A</p>
	<p>DRAWN BY: MVS</p>	<p>DATE DRAWN: 11/6/18</p>
	<p>MODEL(S): See Sheet 3</p>	<p>REV. DATE: 3/8/22</p>
		<p>SHEET: 2 OF 4</p>

MODEL NUMBERS AND LITE OPTIONS

MODEL NUMBERS AVAILABLE	LITE OPTIONS AVAILABLE				
	CARRIAGE HOUSE	RANCH	STANDARD	LARGE COMMERCIAL 24 x 12	SMALL COMMERCIAL 24 x 6
PAN C2011 SERIES				X	X
PAN C2015 SERIES				X	X
PAN C2411 SERIES				X	X
PAN C2415 SERIES				X	X
PAN C2511 SERIES				X	X
PAN C2410 & R2410 SERIES	X	X	X		
PAN C2460 & R2460 SERIES	X				
PAN C2461 & R2461 SERIES	X				
PAN C2470 & R2470 SERIES		X			
PAN C2471 & R2471 SERIES		X			
PAN C2472 & R2472 SERIES		X			
PAN C2480 & R2480 SERIES			X		
PAN C2481 & R2481 SERIES			X		
PAN C2482 & R2482 SERIES			X		
PAN R2560 SERIES	X				
PAN R2561 SERIES	X				
PAN R2570 SERIES		X			
PAN R2571 SERIES		X			
PAN R2572 SERIES		X			
PAN R2580 SERIES			X		
PAN R2581 SERIES			X		
PAN R2582 SERIES			X		
	38 1/2" x 12 5/8"	38 1/2" x 10 1/2"	17 1/4" x 10 1/4"	21 1/2" x 9 1/2"	21 1/2" x 3 1/4"
DAY LIGHT OPENING (DLO) - WIDE x TALL					

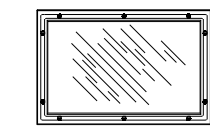
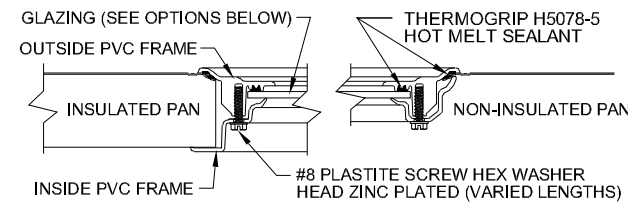

SCREW LOCATION - STANDARD LITE
NOTE: 10 SCREWS USED.

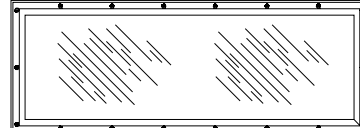

SCREW LOCATION - CARRIAGE HOUSE & RANCH LITES
NOTE: 18 SCREWS USED.

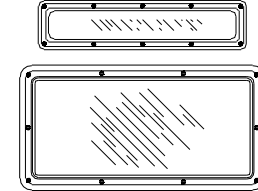

SCREW LOCATION - COMMERCIAL LITES
NOTE: 10 SCREWS USED.

GLAZING DETAIL

NOTE: GLAZING IS AVAILABLE IN 1/8" ANNEALED GLASS, 1/8" THICK TEMPERED GLASS, 1/2" INSULATED GLASS UNITS CONSISTING OF TWO PIECES OF 1/8" THICK TEMPERED GLASS AND A 1/4" SPACER, 1/8" ACRYLIC (SABIC INNOVATIVE PLASTICS) AND 1/8" POLYCARBONATE (LEXAN OR MAKROLON/TUFFAK). THE DAY LIGHT OPENING (DLO) OF EACH LITE OPTION IS LISTED IN THE MODEL NUMBERS AND LITE OPTIONS CHART ON SHEET 3 OF 4.

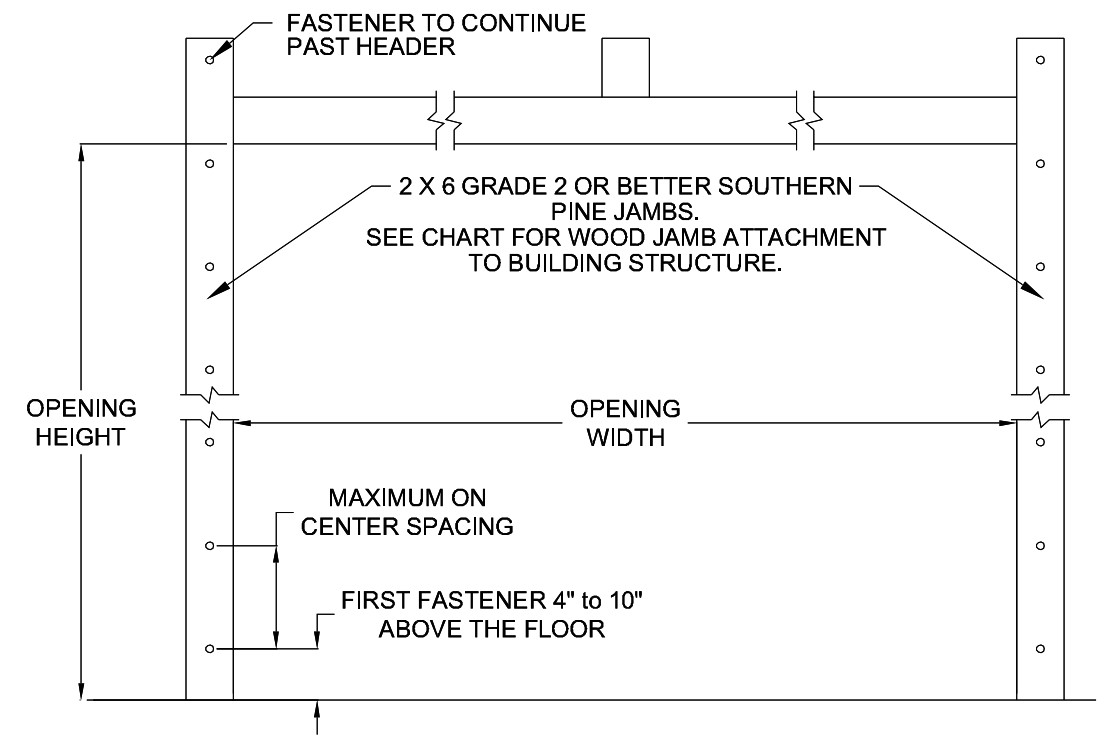

WOOD JAMB ATTACHMENT						
Building Structure	Fastener Type	Minimum Embedment	Minimum Edge Distance	Minimum on Center Spacing	Maximum on Center Spacing	Allowable Tension Load
Min. 2500 PSI to 4000 PSI Concrete	Tapcon + (PLUS) 1/4" w/ 1" OD washer	2"	2.50"	5.00"	24"	551
Southern Pine	3/8" Lag w/ 1 1/8" OD washer	1.50"	1.50"	1.50"	24"	620
Spruce Pine Fir	3/8" Lag w/ 1 1/8" OD washer	1.50"	1.50"	1.50"	24"	482

NOTE: 2X6 mounted to the wall must be Southern Pine Grade 2 or better.

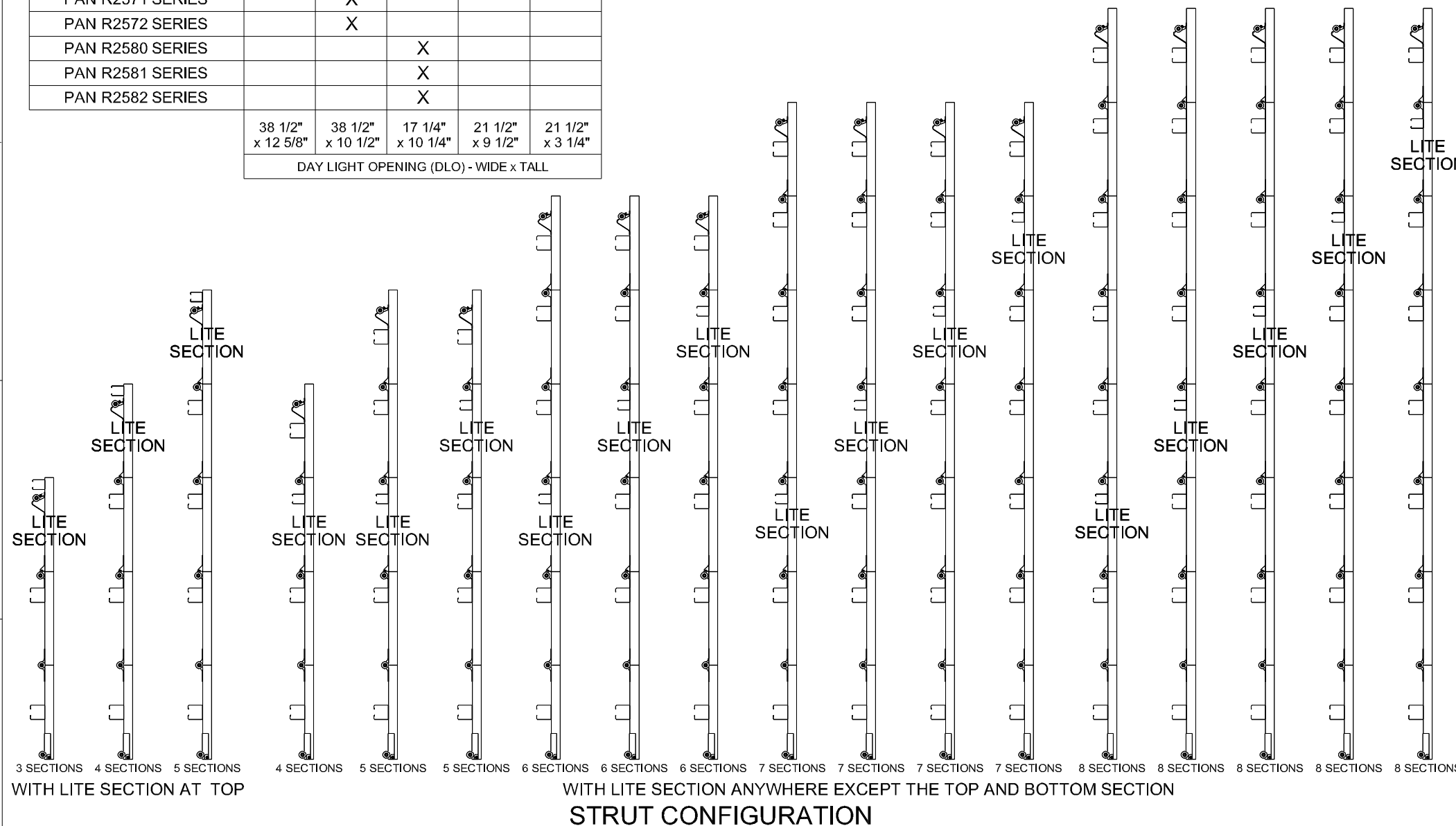

John E. Scates, P.E.
2560 King Arthur Blvd. Ste 124-54
Lewisville, Texas 75056
Texas P.E. 56308/F2203

Professional Engineer seal provided only for verification of wind load construction details.



DESCRIPTION: 10' 2" PAN 2000 SERIES W/LITES WIND LOAD SECTIONAL DOOR DESIGN PRESSURE +21.3/-24.1 PSF			
DRAWING NO.: WLT-2000-0122-08-21-24L	REV.: A		
DRAWN BY: MVS	DATE DRAWN: 11/6/18	REV. DATE: 3/8/22	
MODEL(S): See Sheet 3			SHEET: 3 OF 4

320 Sycamore
Wauseon, Ohio 43567
© Copyright 2014

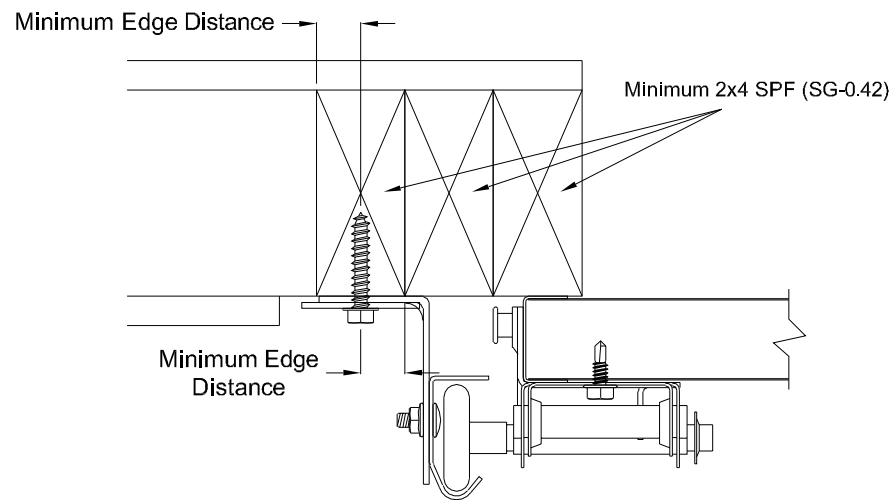

Direct Wood Mounting Detail

Bracket Mount Shown, Reverse and Continuous Angle Mount Also Approved As Alternate.

439 lbs. per anchor allowable load

5/16" Dia. Lag Screw w/1-1/8" O.D. Flat Washer (shall conform to ANSI/ASME standard B18.2.1)

Minimum Screw Length: Spruce-Pine-Fur (SPF) - 2-1/2"
Southern Pine - 1-5/8"

Minimum Edge Distance: 1/2"

Maximum on Center Spacing: 24"

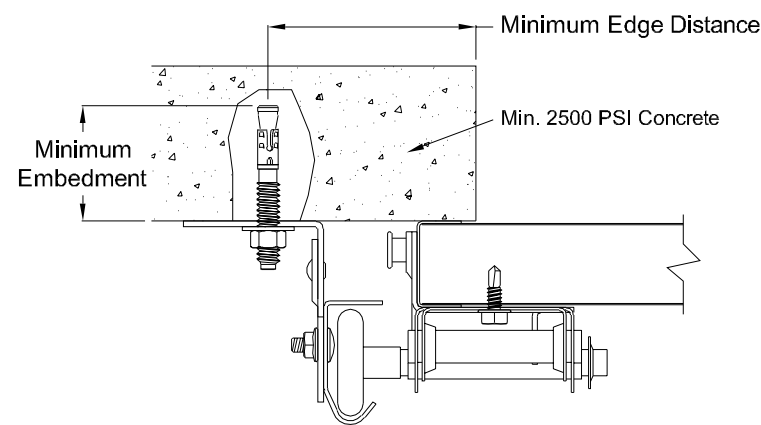

Direct Concrete Mounting Detail

Continuous Angle Clip Mount Shown, Bracket and Reverse Continuous Angle Mount Also Approved As Alternate.

831 lbs. per anchor allowable load

3/8" Dia. Ankr-Tite CCAT w/1-1/8" O.D. Flat Washer (by Wej-It Fastening Systems)

Minimum Embedment: 2-5/8"

Minimum Edge Distance: 2-1/2"

Minimum on Center Spacing: 6"

Maximum on Center Spacing: 24"

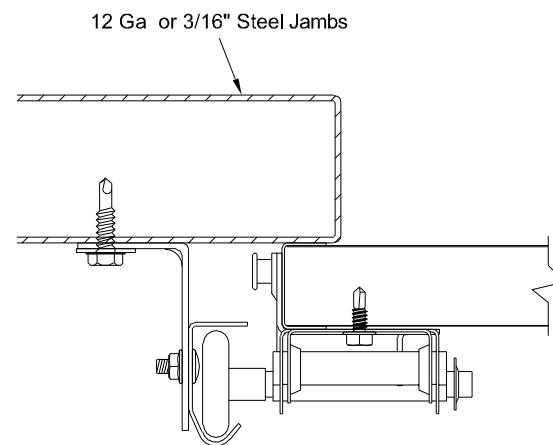

Direct Steel Mounting Detail

Bracket Mount Shown, Reverse and Continuous Angle Mount Also Approved As Alternate.

232 lbs. per anchor allowable load - 12 Ga Steel

569 lbs. per anchor allowable load - 3/16" Ga Steel
5/16"-12 Tek Self-Drilling Screw w/9/16" O.D. Flat Washer

12 Ga Maximum on Center Spacing: 24"

3/16" Maximum on Center Spacing: 24"

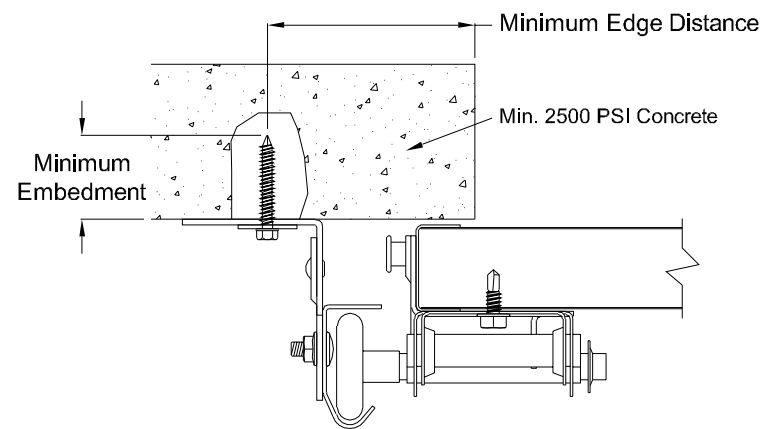

Direct Concrete Mounting Detail

Continuous Angle Clip Mount Shown, Bracket and Reverse Continuous Angle Mount Also Approved As Alternate.

562 lbs. per anchor allowable load

1/4" Dia. Concrete Self-Tapping & Wedge Anchor w/1" O.D. Flat Washer (Includes Tapcon+ (by ITW),

Wedge-Bolt+ (by Powers Fasteners) & Red Head

TruBolt wedge anchor (by ITW))

Minimum Embedment: 2"

Minimum Edge Distance: 2-1/2"

Minimum on Center Spacing: 5"

Maximum on Center Spacing: 24"

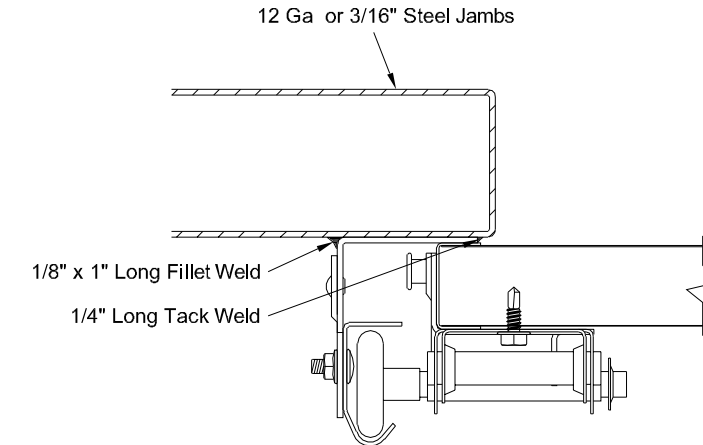

Direct Steel Mounting Detail

Reverse Continuous Angle Clip Mount Shown, Continuous Angle Mount Also Approved As Alternate.

1272 lbs. per anchor allowable load

1/8" Nom. x 1" Long Fillet and 1/4" Long Tack Weld (E60xx Electrodes Min.)

Welds performed by a certified welder or inspected by a certified welding inspector to verify integrity of the welds.

Maximum on Center Spacing: Apply welds at each roller location not to exceed 24"

John E. Scates, P.E.
2560 King Arthur Blvd. Ste 124-54
Lewisville, Texas 75056
Texas P.E. 56308/F2203

Professional Engineer seal provided only for verification of wind load construction details.



DESCRIPTION: 10' 2" PAN 2000 SERIES W/LITES WIND LOAD SECTIONAL DOOR DESIGN PRESSURE +21.3/-24.1 PSF			
DRAWING NO.: WLT-2000-0122-08-21-24L	REV.: A		
DRAWN BY: MVS	DATE DRAWN: 11/6/18	REV. DATE: 3/8/22	
MODEL(S): See Sheet 3	SHEET: 4 OF 4		

320 Sycamore
Wauseon, Ohio 43567
© Copyright 2014