

CLOPAY MODEL 902, 903
IDEAL MODEL C2AL, C3AL

REVISIONS					
REV. NO.	ZONE:	DATE:	ECN NO.	APPVD:	DESCRIPTION
00	-	2/6/17	-	-	INITIAL RELEASE
01	-	02/2022	-	JDW	REVISED FOR TDI.

THIS PRODUCT COMPLIES WITH THE 2018 IBC/IRC.

DOOR IS MADE OF 6063-T5 ALUMINUM EXTRUSIONS. WALL THICKNESS:
 TOP RAIL _____ .075
 INTER. TOP & BOTTOM RAILS _____ .075
 TOP HAS .1 x 1.875" FIN
 INTER. TOP RAIL CAP _____ .040
 SINGLE & DOUBLE END STILES .075
 CENTER STILES _____ .062
 HD BTM RAIL _____ .179

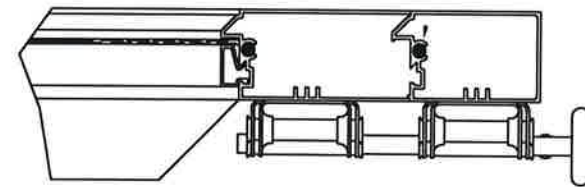

REINFORCING FIN ON INTER. TOP RAILS ANGLE CUT AT END STILES

SECTION 4 - 4

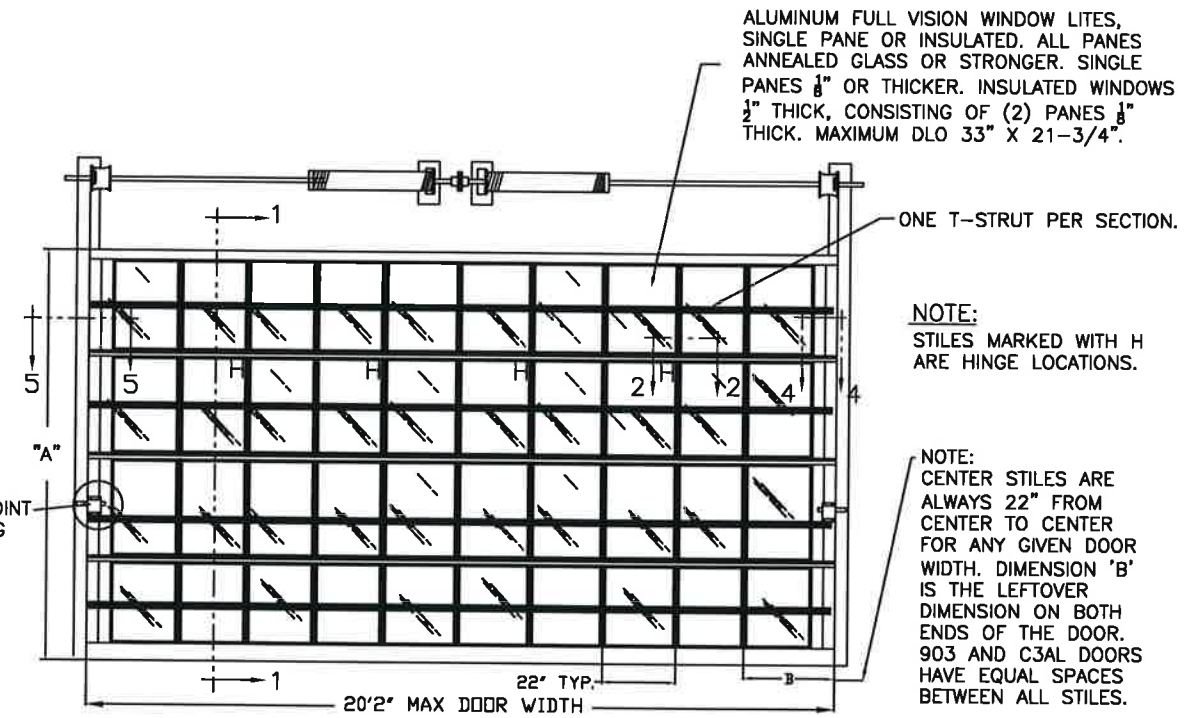

ALUMINUM FULL VISION WINDOW LITES, SINGLE PANE OR INSULATED. ALL PANES ANNEALED GLASS OR STRONGER. SINGLE PANES 3/8" OR THICKER. INSULATED WINDOWS 1/2" THICK, CONSISTING OF (2) PANES 3/8" THICK. MAXIMUM DLO 33" X 21-3/4".

NOTE: STILES MARKED WITH H ARE HINGE LOCATIONS.

NOTE: CENTER STILES ARE ALWAYS 22" FROM CENTER TO CENTER FOR ANY GIVEN DOOR WIDTH. DIMENSION 'B' IS THE LEFTOVER DIMENSION ON BOTH ENDS OF THE DOOR. 903 AND C3AL DOORS HAVE EQUAL SPACES BETWEEN ALL STILES.

#14x5/8" SHEET METAL SCREWS

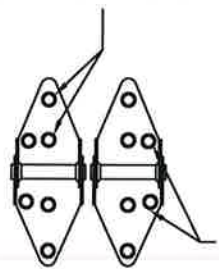

14 GA. END HINGES

1/4"x3/4" SELF TAPPING SCREWS.

CENTER HINGE OF 16 GA. GALV. STEEL, ATTACHED TO INTER. BOTTOM RAIL WITH (2) #14 X 5/8" SHT MTL SCREWS AND TO INTER. TOP RAIL WITH (2) 1/4 - 20 X 1/2" HEX HEAD MACHINE SCREWS & NUTS

DOOR WIDTH	NUMBER OF CENTER STILES	NUMBER OF HINGES
16'-3" THRU 20'-2"	9	4

DOOR HEIGHT 'A'	NUMBER OF SECTIONS
UP TO 8'-0"	4
8'-3" THRU 10'-0"	5
10'-3" THRU 12'-0"	6
12'-3" THRU 14'-0"	7
14'-3" THRU 16'-0"	8
16'-3" THRU 18'-0"	9

MAX. SECTION HEIGHT: 24"

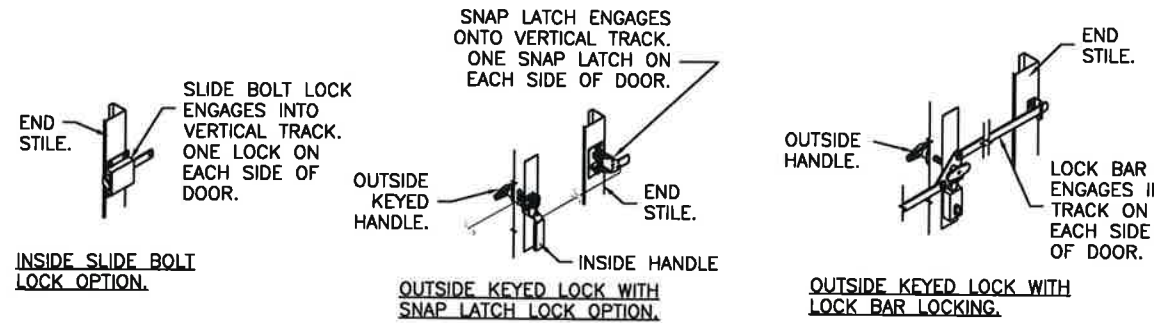

INSIDE SLIDE BOLT LOCK OPTION.

OUTSIDE KEYED LOCK WITH SNAP LATCH LOCK OPTION.

OUTSIDE KEYED LOCK WITH LOCK BAR LOCKING.

Mark Westerfield
 MARK W. WESTERFIELD
 5/31/22
 P.E. #1513
 PROFESSIONAL ENGINEER

DESIGN ENGINEER: MARK WESTERFIELD, P.E.
 FLORIDA P.E. #48495, NC P.E. #23832, TEXAS P.E. #91513

DESIGN LOADS: +30 & -30 P.S.F.
 TEST LOADS +45 & -45 P.S.F.

Unless Stated Otherwise TOLERANCES are
 .0 = ±.031
 .00 = ±.015
 .000 = ±.005
 .0000 = ±.001
 Degrees = ±1/2"

Unless Stated Otherwise DIMENSIONS ARE IN INCHES.

Glopay CORPORATION
 8585 Duke Boulevard
 Mason, OH 45040 USA
 Tel. No. 513-770-4800
 Fax No. 513-770-4853

DESCRIPTION: M/N 902, C2AL, 20'2" WIDE DES. +30/-30 PSF

DRAWN BY: RJH	DATE: 2/6/17	SCALE: NTS	DWG. SIZE B
CHECKED BY: -	DATE: -	SHEET 1 OF 3	
DWG. NO.: 105088	VER: TDI		

MANUFACTURING PRODUCT CODE:
MPC: C-AL-1F499

PART NO.: N/A

CLOPAY WINDLOAD RATING
W5

CLOPAY MODEL 902, 903
IDEAL MODEL C2AL, C3AL

REVISIONS					
REV. NO.	ZONE	DATE	ECN NO.	APPVD.	DESCRIPTION
01	-	-	-	-	SEE REVISION HISTORY ON SHEET 1

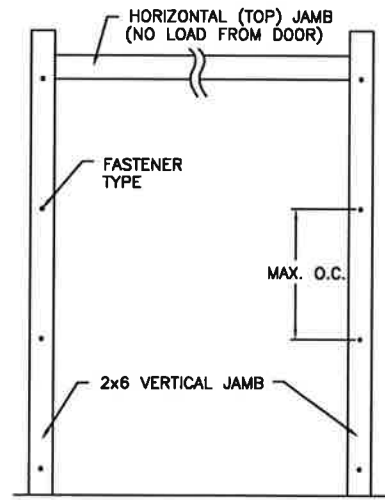

JAMB TO SUPPORTING STRUCTURE ATTACHMENT

- NOTES:**
1. ALL THE LOAD FROM THE DOOR IS TRANSFERRED TO THE TRACK AND THEN FROM THE TRACK TO THE 2x6 VERTICAL SYP (GRADE #2 OR BETTER) JAMBS. NO LOAD FROM THE DOOR IS TRANSFERRED TO THE HORIZONTAL (TOP) JAMB.
 2. EACH VERTICAL JAMB SEES A MAXIMUM DESIGN LOAD OF +300 LB & -300 LB. PER LINEAR FOOT OF JAMB.
 3. ALL JAMB FASTENERS MAY BE (BUT ARE NOT REQUIRED TO BE) COUNTERSUNK TO PROVIDE A FLUSH MOUNTING SURFACE.
 4. A 1/3 STRESS INCREASE FOR WIND LOAD WAS NOT USED IN THE CALCULATION OF ALLOWABLE LOADS FOR ANCHORS AND FASTENERS FOR STEEL, CONCRETE AND MASONRY.

NOTE: 2x6 WOOD JAMBS ARE NOT REQUIRED WITH CONTINUOUS ANGLE MOUNT TRACK. HOWEVER, IF DESIRED ON STEEL JAMBS OR CONCRETE OR BLOCK WALLS, APPROVED FASTENERS AS DETAILED BELOW SHOULD BE INCREASED IN LENGTH BY 1-1/2" AND INSTALLED DIRECTLY THROUGH THE ANGLE AND 2x6 WOOD JAMBS INTO THE STEEL JAMBS OR CONCRETE OR BLOCK WALLS. ANCHORS CAN BE (BUT ARE NOT REQUIRED TO BE) COUNTERSUNK TO PROVIDE A FLUSH MOUNTING SURFACE. CONTINUOUS ANGLE TRACK CAN BE ANCHORED DIRECTLY TO GROUT REINFORCED BLOCK WALL OR 3,000 PSI MIN. CONCRETE COLUMN OR STEEL JAMBS.

FASTENER ATTACHMENT TO SUPPORTING STRUCTURE SCHEDULES

BUILDING TYPE	FASTENER TYPE	MAXIMUM ON-CENTER DISTANCE BETWEEN FASTENERS*	STEEL WASHERS REQUIRED?
HOLLOW BLOCK WALL	1/4" x 1-1/4" MIN. EMBED ULTRACON CONCRETE ANCHOR	5-1/2"	1" O.D.
GROUT FILLED BLOCK WALL	1/4" x 1-3/4" MIN. EMBED ULTRACON CONCRETE ANCHOR	9"	1" O.D.
2000 PSI MIN. CONCRETE	1/4" x 1" MIN. EMBED ULTRACON CONCRETE ANCHOR	8"	1" O.D.
2000 PSI MIN. CONCRETE	1/4" x 1" MIN. EMBED TAPCON CONCRETE ANCHOR	7-1/2"	1" O.D.
2000 PSI MIN. CONCRETE	3/8" x 1-3/4" MIN. EMBED WEJ-IT ANKR TITE SLEEVE ANCHOR	16-3/4"	INCLUDED
4000 PSI MIN. CONCRETE	3/8" x 1-3/4" MIN. EMBED WEJ-IT ANKR TITE SLEEVE ANCHOR	24"	INCLUDED
WOOD FRAME (SYP 0.55 SG)	1/2" x 3" LAG SCREW (ASTM A307, GRADE A) 1-5/8" EMBED INTO STRUCTURE	18"	1" O.D.
14GA STEEL (0.060" MIN.)	1/4"-14 x 1" ITW BUILDEX TEKS SELF-DRILLING FASTENER	7-1/2"	1" O.D.
12GA STEEL (0.105" MIN.)	1/4"-14 x 1" ITW BUILDEX TEKS SELF-DRILLING FASTENER	13-1/4"	1" O.D.
1/8" STEEL	1/4"-14 x 1" ITW BUILDEX TEKS SELF-DRILLING FASTENER	15-3/4"	1" O.D.

*FIRST (BOTTOM) ANCHOR STARTING AT NO MORE THAN HALF OF THE MAXIMUM ON-CENTER DISTANCE. HIGHEST ANCHOR INSTALLED AT LEAST AS HIGH AS THE DOOR OPENING.
CLOPAY DOES NOT SUPPLY JAMB ATTACHMENT FASTENERS.
MINIMUM DISTANCE BETWEEN CENTER OF ANCHOR AND EDGE OF CONCRETE BLOCK: 2-1/2", EXCLUDING STUCCO THICKNESS.

DESIGN ENGINEER: MARK WESTERFIELD, P.E.
FLORIDA P.E. #48495, NC P.E. #23832, TEXAS P.E. #91513

SECTION 1-1

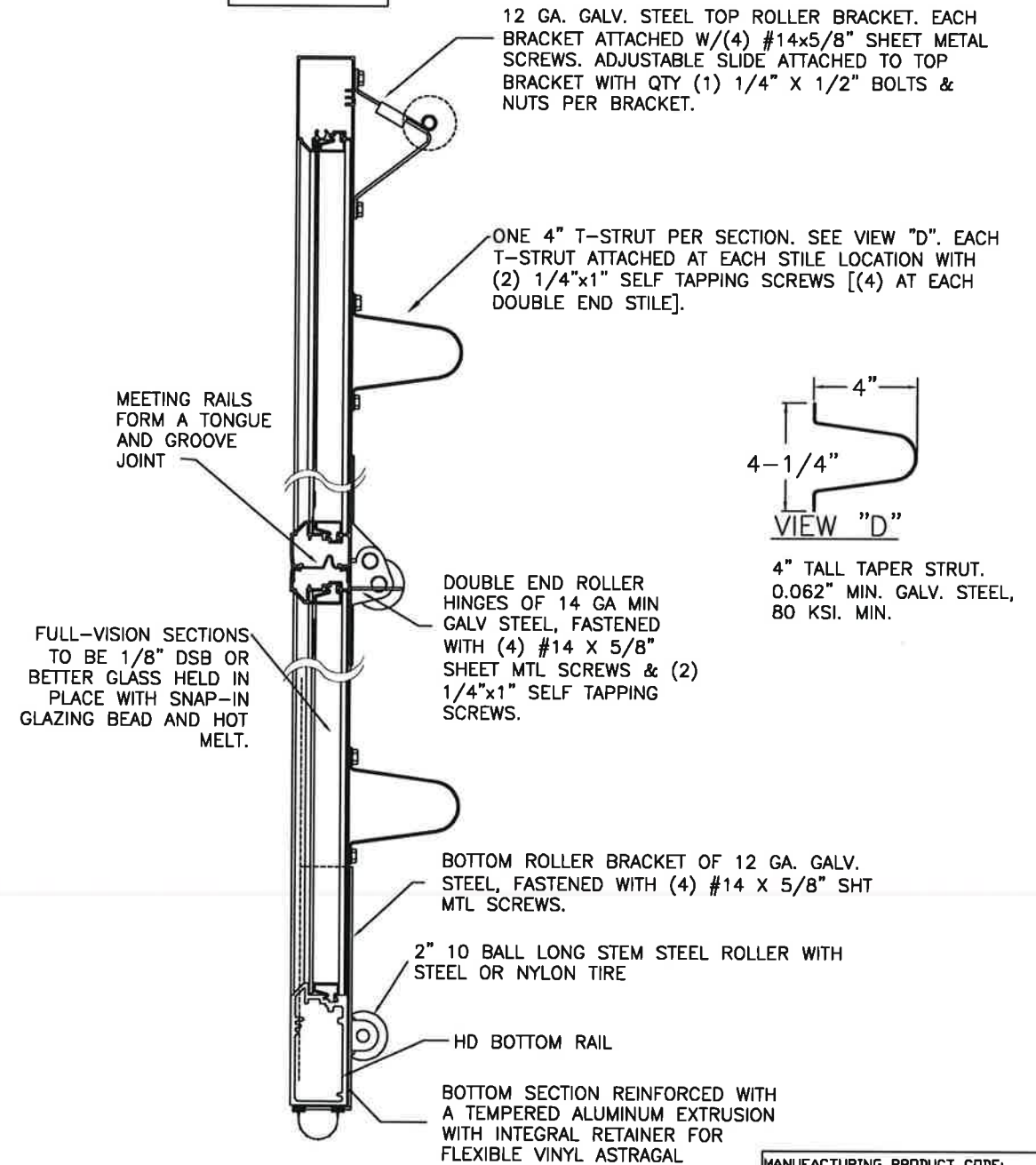

DESIGN LOADS: +30 & -30 P.S.F.
TEST LOADS +45 & -45 P.S.F.

Unless Stated Otherwise
TOLERANCES are
.0 = ±.031
.00 = ±.015
.000 = ±.005
.0000 = ±.001
Degrees = ±1/2°

Unless Stated Otherwise
DIMENSIONS ARE IN INCHES.

Clopay
CORPORATION

8585 Duke Boulevard
Mason, OH 45040 USA
Tel. No. 513-770-4800
Fax No. 513-770-4853

DESCRIPTION: M/N 902, C2AL, 20'2" WIDE DES. +30/-30 PSF

DRAWN BY: RJH DATE: 2/6/17 SCALE: NTS DWG. B

CHECKED BY: - DATE: - SHEET 2 OF 3 SIZE B

DWG. NO.: 105088 VER: TDI

MANUFACTURING PRODUCT CODE:
MPC: C-AL-1F499

PART NO.: N/A

CLOPAY WINDLOAD RATING
W5

CLOPAY MODEL 902, 903
IDEAL MODEL C2AL, C3AL

REVISIONS					
REV. NO.	ZONE	DATE	ECN NO.	APPVD.	DESCRIPTION
01	-	-	-	-	SEE REVISION HISTORY ON SHEET 1

2" TRACK CONFIGURATION.

NOTE DOUBLE TRACK LOW HEADROOM, HI-LIFT TRACK, FOLLOW-THE-ROOF TRACK, AND VERTICAL LIFT TRACK ARE AVAILABLE OPTIONS. TRACK CONFIGURATION ABOVE THE DOOR OPENING DOES NOT AFFECT THE WIND LOAD RATING.

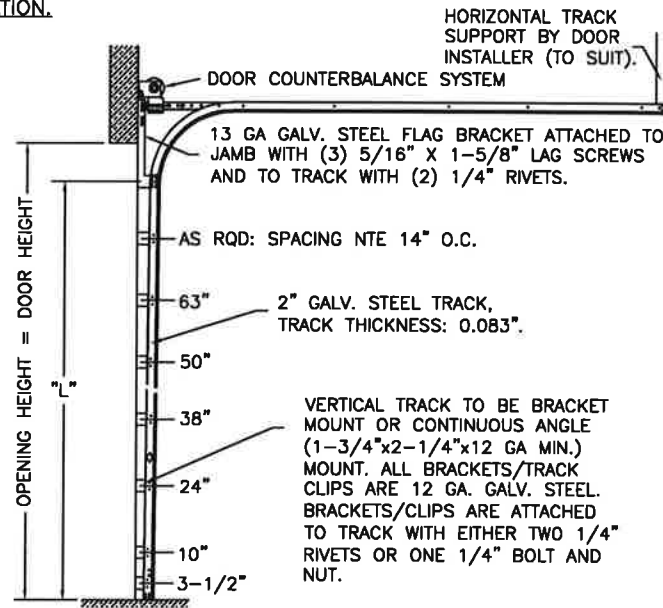

DOOR HEIGHT	"L"
6'-6"	70"
7'-0"	76"
7'-6"	82"
8'-0"	88"
8'-6"	94"
9'-0"	100"
9'-6"	106"
10'-0"	112"
10'-6"	118"
11'-0"	124"
11'-6"	130"
12'-0"	136"
12'-6"	142"
13'-0"	148"
13'-6"	154"
14'-0"	160"
14'-6"	166"
15'-0"	172"
15'-6"	178"
16'-0"	184"
16'-6"	190"
17'-0"	196"
17'-6"	202"
18'-0"	208"

JAMB CONFIGURATION FOR 2" TRACK.

BRACKET MOUNT JAMB CONFIGURATION

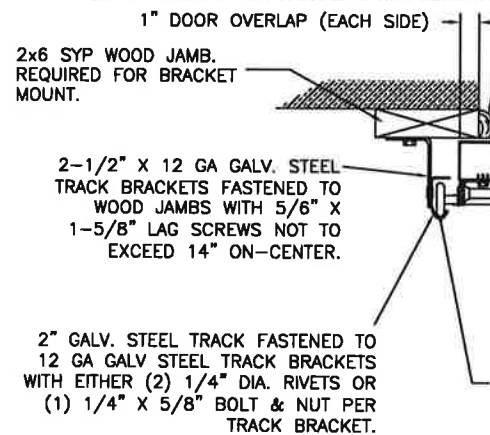

ANGLE MOUNT JAMB CONFIGURATION

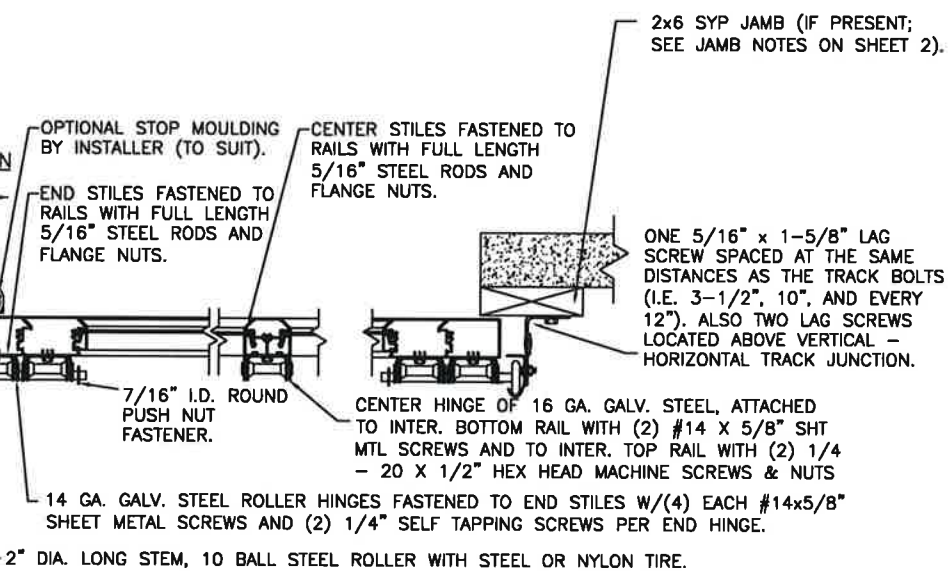

SECTION C-C

PREPARATION OF JAMBS BY OTHERS.

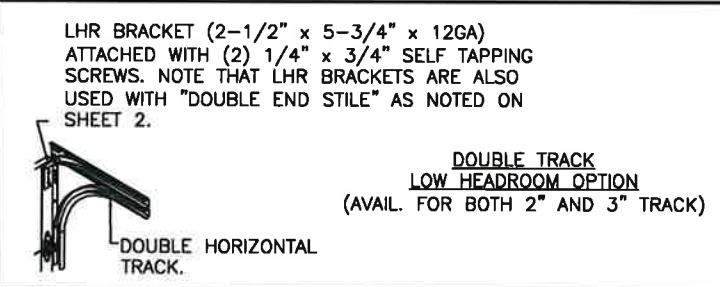

3" TRACK CONFIGURATION.

NOTE DOUBLE TRACK LOW HEADROOM, HI-LIFT TRACK, FOLLOW-THE-ROOF TRACK, AND VERTICAL LIFT TRACK ARE AVAILABLE OPTIONS. TRACK CONFIGURATION ABOVE THE DOOR OPENING DOES NOT AFFECT THE WIND LOAD RATING.

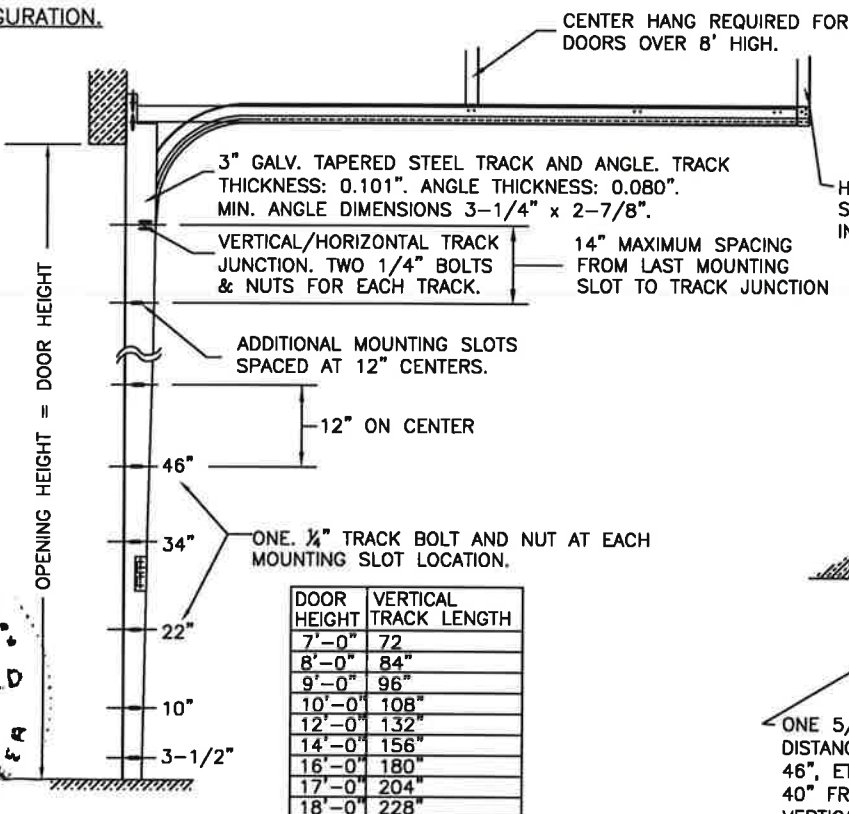

DOOR HEIGHT	VERTICAL TRACK LENGTH
7'-0"	72"
8'-0"	84"
9'-0"	96"
10'-0"	108"
12'-0"	132"
14'-0"	156"
16'-0"	180"
17'-0"	204"
18'-0"	228"

JAMB CONFIGURATION FOR DOORS WITH 3" TRACK.

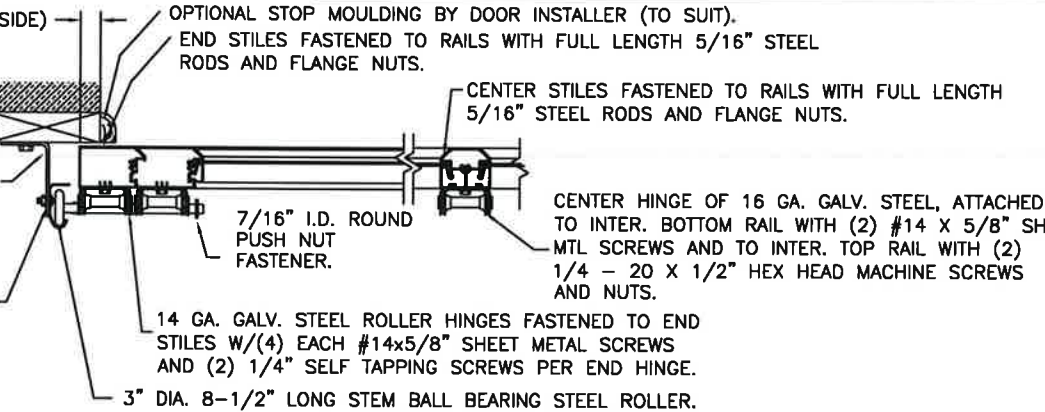
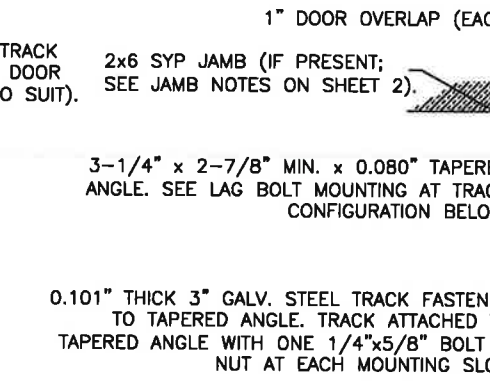

SECTION C-C

PREPARATION OF JAMBS BY OTHERS.

DESIGN LOADS: +30 & -30 P.S.F.
TEST LOADS: +45 & -45 P.S.F.

Unless Stated Otherwise TOLERANCES are
.0 = ±.031
.00 = ±.015
.000 = ±.005
.0000 = ±.001
Degrees = ±1/2°



8585 Duke Boulevard
Mason, OH 45040 USA
Tel. No. 513-770-4800
Fax No. 513-770-4853

MANUFACTURING PRODUCT CODE:
MPC: C-AL-1F499

PART NO.: N/A

CLOPAY WINDLOAD RATING
W5

DESCRIPTION: M/N 902, C2AL, 20'2" WIDE DES. +30/-30 PSF

DRAWN BY: RJH

DATE: 2/6/17

SCALE: NTS

DWG. B

CHECKED BY: -

DATE: -

SHEET 3 OF 3

SIZE B

DWG. NO.: 105088

VER: TDI

DESIGN ENGINEER: MARK WESTERFIELD, P.E.
FLORIDA P.E. #48495, NC P.E. #23832, TEXAS P.E. #91513

Handwritten signature and date: 5/31/22