

MAX 20'-2" WIDE X 18'-0" HIGH

MODELS AVAILABLE (CLOPAY/ HOLMES/ IDEAL)  
 MODELS 524, 520/ 224/ C4ST, C0ST  
 INSULATED MODELS 524S, 520S, 524V/ 224S/ C4SS, C0SS, C4SV

DOOR HEIGHT 'A'	NUMBER OF SECTIONS
UP TO 8'-0"	4
8'-3" THRU 10'-0"	5
10'-3" THRU 12'-0"	6
12'-3" THRU 14'-0"	7
14'-3" THRU 16'-0"	8
16'-3" THRU 18'-0"	9

DOOR WIDTH	NUMBER OF CENTER STILES	NUMBER OF C-CHANNEL STRAPS
16'-3" THRU 16'-6"	7	6
16'-7" THRU 20'-2"	9	7

MAX. SECTION HEIGHT: 24"

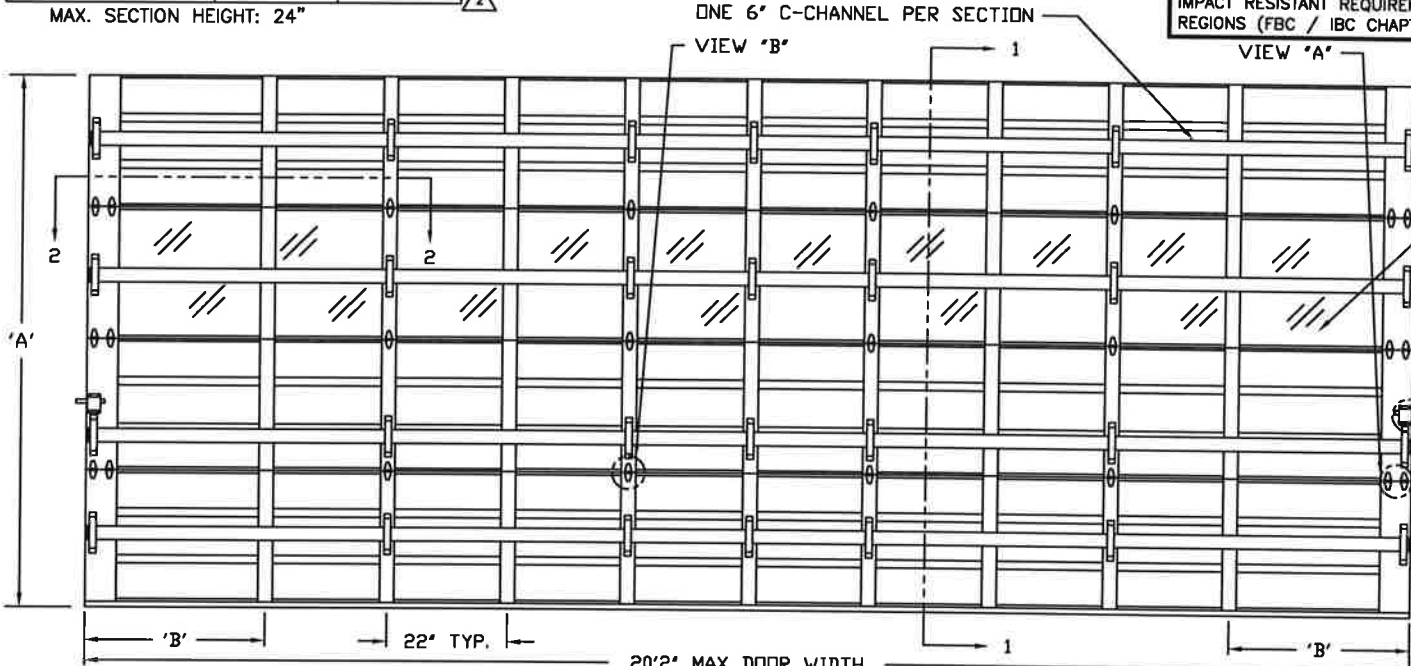
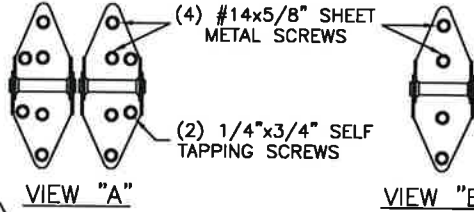
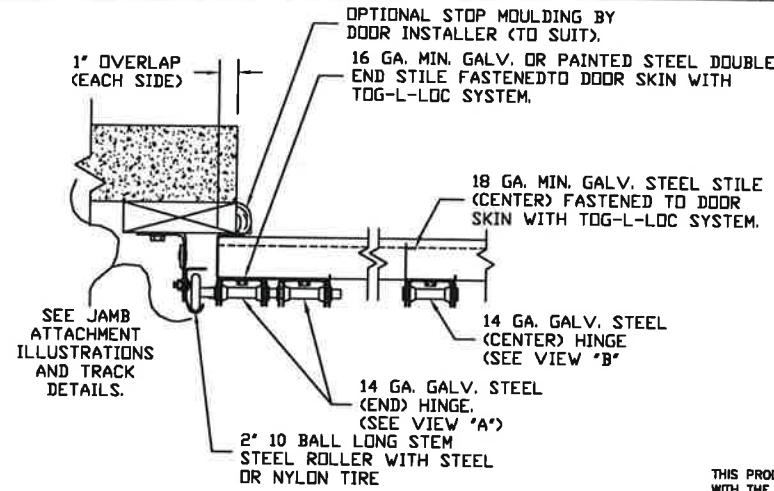

OPTIONAL ALUMINUM FULL VISION WINDOW LITE SECTIONS AVAILABLE. SINGLE PANE OR INSULATED. ALL PANES ANNEALED GLASS OR STRONGER. SINGLE PANES 1/8" OR THICKER. INSULATED WINDOWS 1/2" THICK, CONSISTING OF (2) PANES 1/8" THICK. FULL VISION SECTIONS TO HAVE SAME REINFORCEMENT AS OTHER SECTIONS. MAXIMUM DLO: 33" X 21-1/4".

TWO POINT LOCKING

NOTE: CENTER STILES ALWAYS 22" FROM CENTER TO CENTER FOR ANY GIVEN DOOR WIDTH. DIMENSION 'B' IS THE LEFTOVER DIMENSION ON BOTH ENDS OF THE DOOR. THIS DIMENSION WILL NOT BE GREATER THAN 33" OR LESS THAN 18"

ANCHOR NOTE: FIRST (BOTTOM) ANCHOR STARTING AT NO MORE THAN HALF OF THE MAXIMUM ON-CENTER DISTANCE. HIGHEST ANCHOR INSTALLED AT LEAST AS HIGH AS THE DOOR OPENING.

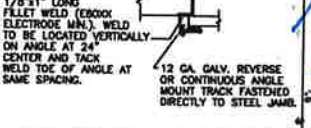
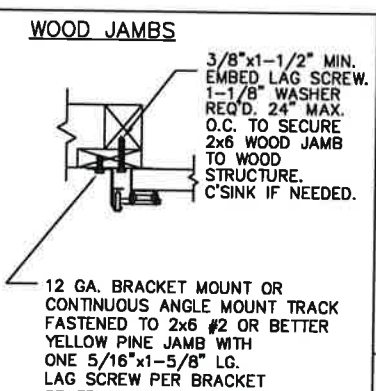
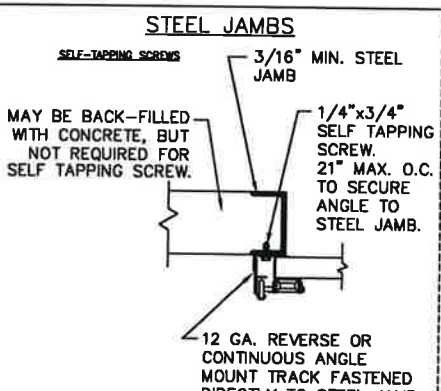
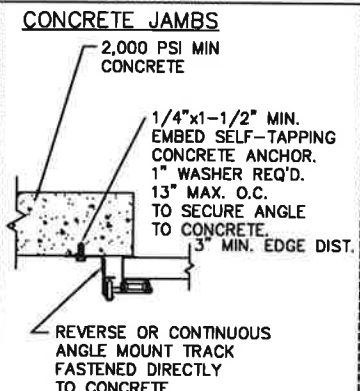
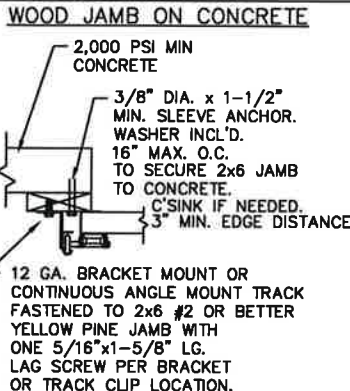

12 GA. BRACKET MOUNT OR CONTINUOUS ANGLE MOUNT TRACK FASTENED TO 2x6 #2 OR BETTER YELLOW PINE JAMB WITH ONE 5/16"x1-5/8" LG. LAG SCREW PER BRACKET OR TRACK CLIP LOCATION.

REVERSE OR CONTINUOUS ANGLE MOUNT TRACK FASTENED DIRECTLY TO CONCRETE.

12 GA. REVERSE OR CONTINUOUS ANGLE MOUNT TRACK FASTENED DIRECTLY TO STEEL JAMB.

12 GA. BRACKET MOUNT OR CONTINUOUS ANGLE MOUNT TRACK FASTENED TO 2x6 #2 OR BETTER YELLOW PINE JAMB WITH ONE 5/16"x1-5/8" LG. LAG SCREW PER BRACKET OR TRACK CLIP LOCATION.

CLOPAY CORP. ALL RIGHTS RESERVED.

Third Angle Projection

REVISIONS					
REV. NO.	ZONE:	DATE:	ECN NO.	APPVD:	DESCRIPTION
10	-	08/2012	-	-	REVISED FOR TDI.
11	-	06/2013	-	-	REMOVED ACRYLIC/WIRE GLAZING. SPECIFIED GLAZING DIMENSION.
12	-	08/2016	-	-	REMOVED WIND SPEED TABLE.
13	-	06/2017	-	-	UPDATED NUMBER OF CENTER STILES AND C-CHANNEL STRAPS
14	-	02/2022	-	-	REVISED FOR TDI.

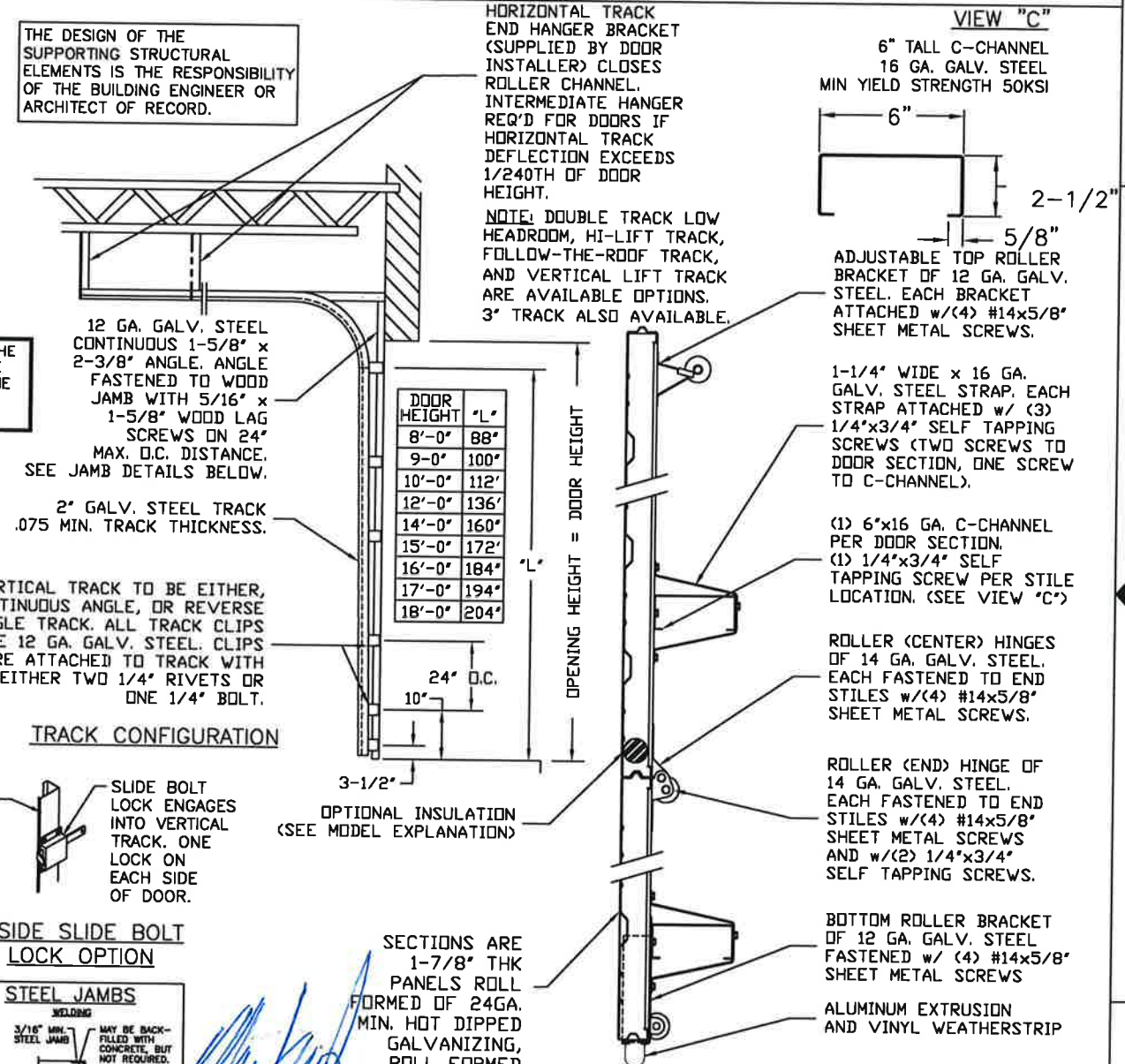

MARK WESTERFIELD, P.E.  
 FLORIDA P.E. #48495,  
 NC P.E. #23832, TEXAS P.E. #91513

DESIGN LOADS: +25 & -25 P.S.F.  
 TEST LOADS +37.5 & -37.5 P.S.F.

MANUFACTURING PRODUCT CODE:  
 MPC: C-PAN-1E448

CLOPAY WINDLOAD RATING  
**W4**

DESCRIPTION: COMMERCIAL RIBBED DOOR, +/- 25 PSF DESIGN LOAD

DRAWN BY: JJM DATE: 3/28/00 SCALE: NTS DWG. B

CHECKED BY: MWW DATE: 3/00 SHEET 1 OF 1 SIZE B

DWG. NO.: 102126 VER: TDI

8585 Duke Boulevard  
 Mason, OH 45040 USA  
 Tel. No. 513-770-4800  
 Fax No. 513-770-4853

STATE OF TEXAS  
 2/23/22

Unless Stated Otherwise  
 TOLERANCES ARE:  
 .0 = ±.031  
 .00 = ±.005  
 .000 = ±.001  
 Degrees = ±1/2"