

BRAND	MODEL
CLOPAY	904, 904U, AX, AXU
IDEAL	C4AL, C4ALU

MADE FROM 6063-T5 ALUMINUM.

THIS PRODUCT COMPLIES WITH THE 2018 IBC/IRC.

DSB LITES OR BETTER, ANNEALED OR TEMPERED. INSULATED GLAZING SHALL CONSIST OF 2 ANNEALED OR TEMPERED DSB LITES. MAX DLO 20.75" X 25.825".

REVISIONS					
REV. NO.	ZONE	DATE	ECN NO.	APPVD.	DESCRIPTION
00	-	4/7/22	-	JDW	RELEASED FOR PRODUCTION

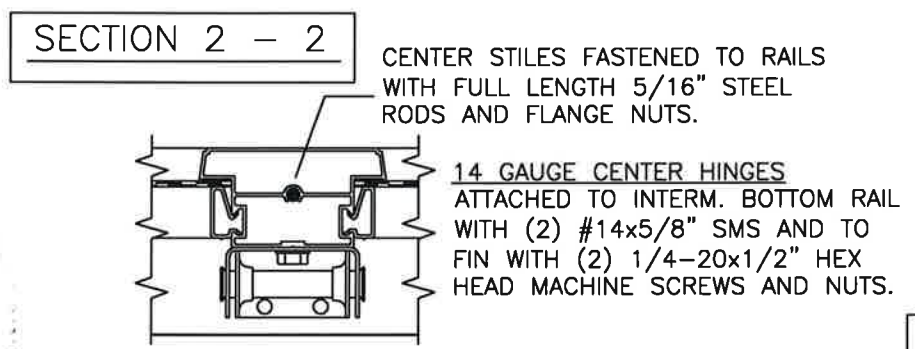
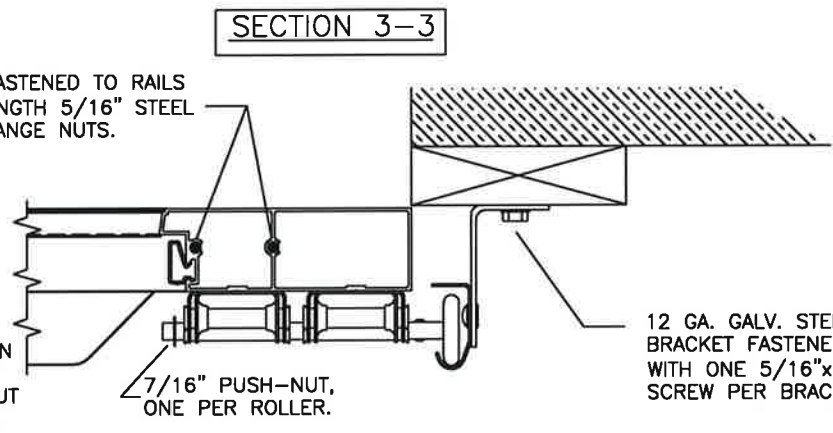
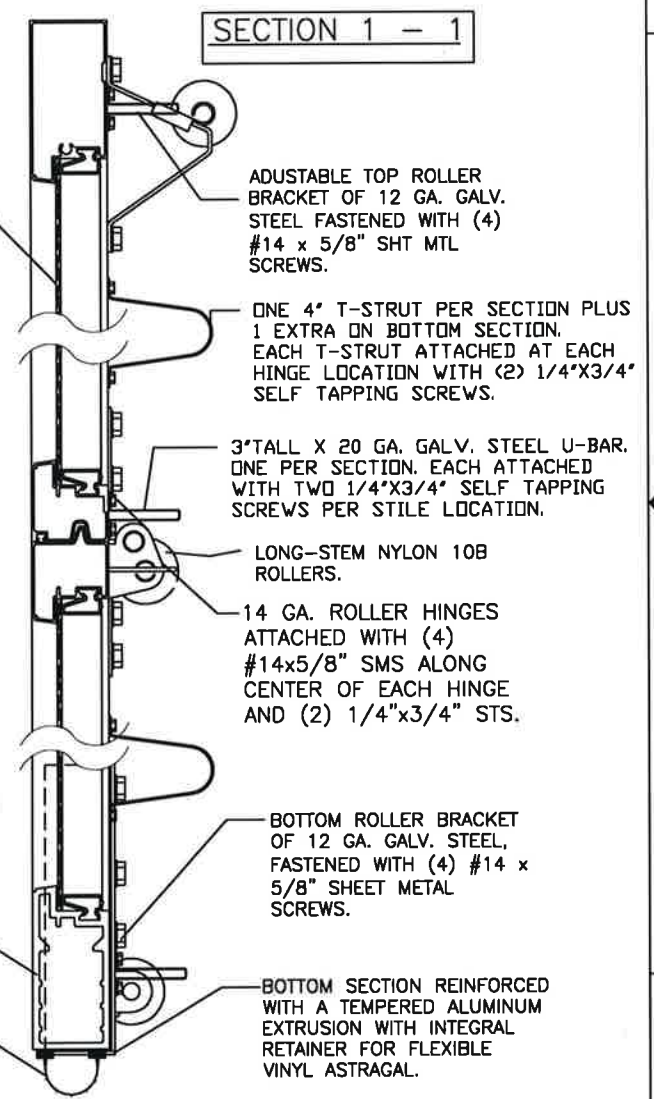
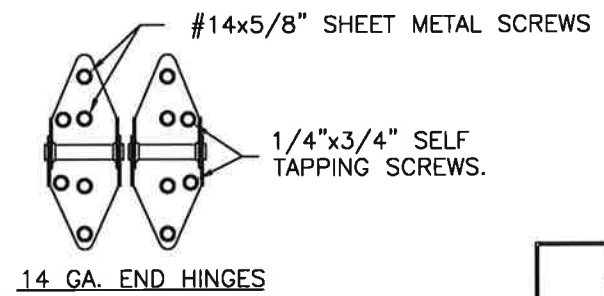
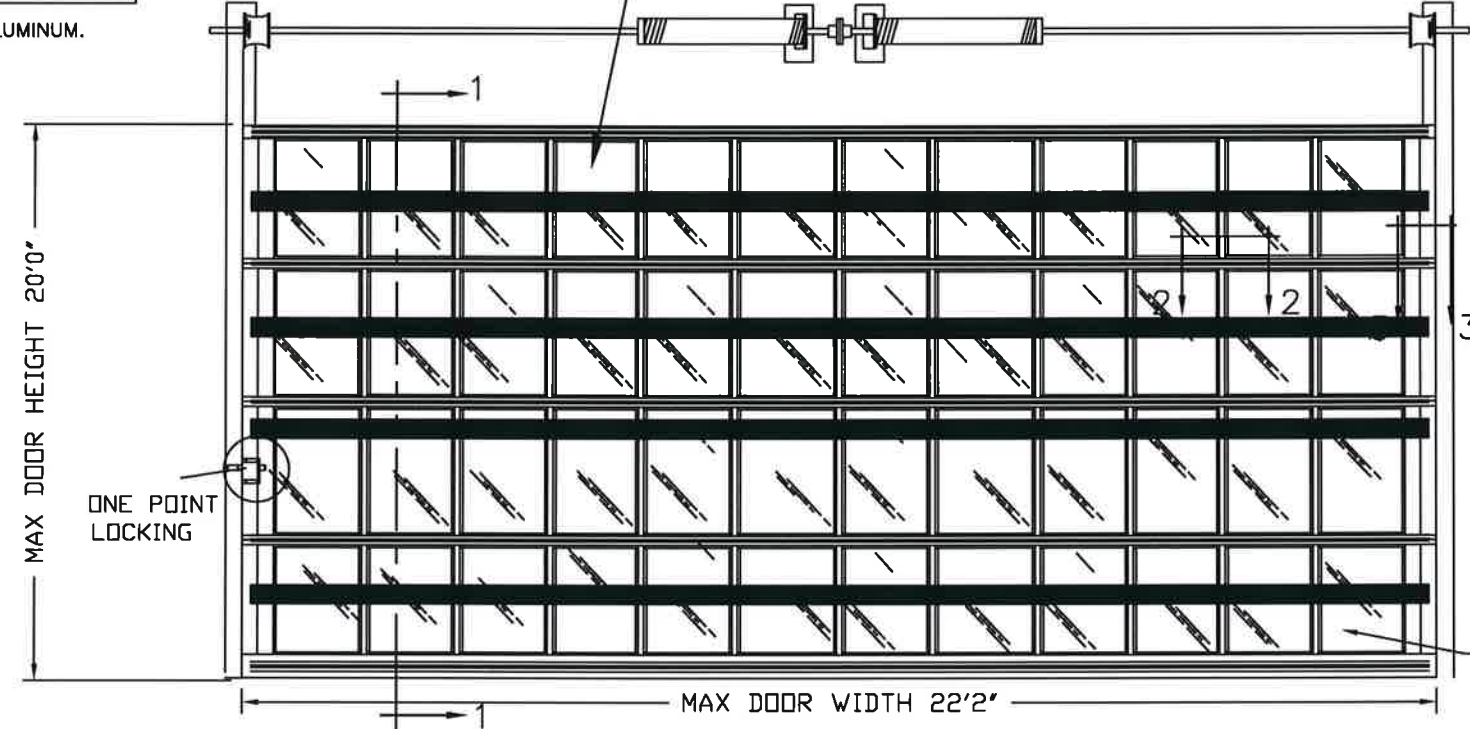

DESIGN PRESSURE: +30.0, -30.0 PSF
TEST PRESSURE: +45.0, -45.0 PSF

Handwritten signature and date: 4/21/22



DESIGN ENGINEER:
MARK WESTERFIELD, P.E.
FLORIDA P.E. #48495
NC P.E. #23832, TEXAS P.E. #91513

MANUFACTURING PRODUCT CODE
C-AL2-1F499

NOTICE: Confidential/Proprietary information of CLOPAY CORPORATION is contained herein and may not be disclosed, used, duplicated, made available, or distributed without its prior consent. Failure to observe this notice may result in liability for any damages and losses resulting therefrom.

Third Angle Projection

Unless Stated Otherwise TOLERANCES are
.0 = ±.031
.00 = ±.015
.000 = ±.005
.0000 = ±.001
Degrees = ±1/2'

Unless Stated Otherwise DIMENSIONS ARE IN INCHES.

Clopay CORPORATION
8585 Duke Boulevard
Mason, OH 45040 USA
Tel. No. 513-770-4800
Fax No. 513-770-4853

PART NO.: -	CLOPAY WINDLOAD RATING W5
DESCRIPTION: M/N 904 22' WIDE DES. +30/-30 PSF	
DRAWN BY: J. WHEELER	DATE: 4/7/22
CHECKED BY: SH	DATE: CHKD_DT
DWG. NO.: 105624	REV. NO. 00

A

4

3

2

1

3" TRACK CONFIGURATION.

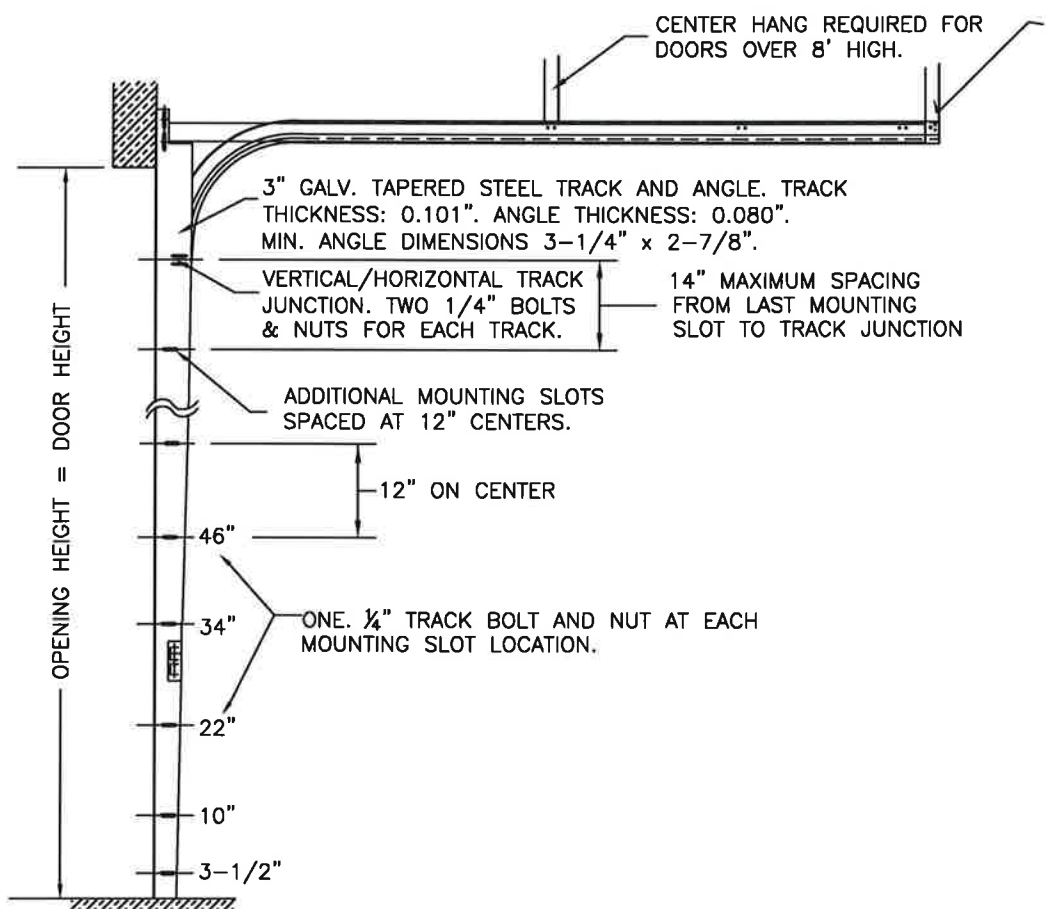

DOOR HEIGHT	VERTICAL TRACK LENGTH
7'-0"	72"
8'-0"	84"
9'-0"	96"
10'-0"	108"
12'-0"	132"
14'-0"	156"
16'-0"	180"
17'-0"	204"
18'-0"	228"
19'-0"	252"
20'-0"	276"

NOTE DOUBLE TRACK HEADROOM, HI-LIFT TRACK, FOLLOW-THE-ROOF TRACK, AND VERTICAL LIFT TRACK ARE AVAILABLE OPTIONS. TRACK CONFIGURATION ABOVE THE DOOR OPENING DOES NOT AFFECT THE WIND LOAD RATING.

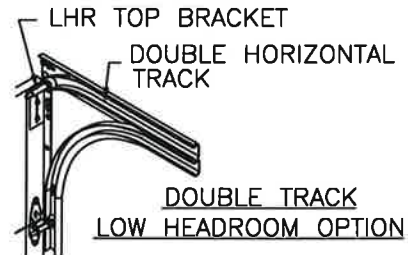

HORIZONTAL TRACK SUPPORT BY DOOR INSTALLER (TO SUIT).

WOOD JAMBS

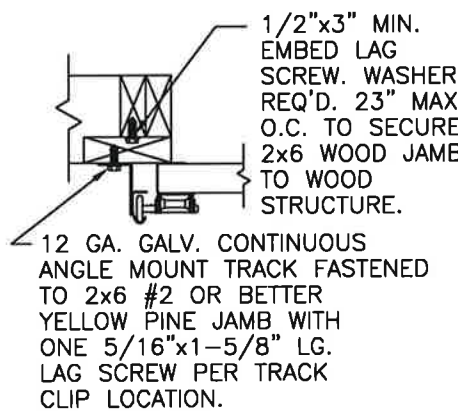

SECTION 3-3

CONCRETE JAMBS

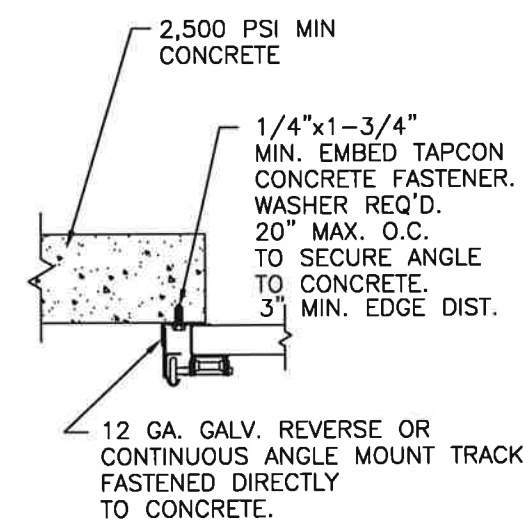

SECTION 3-3

STEEL JAMBS

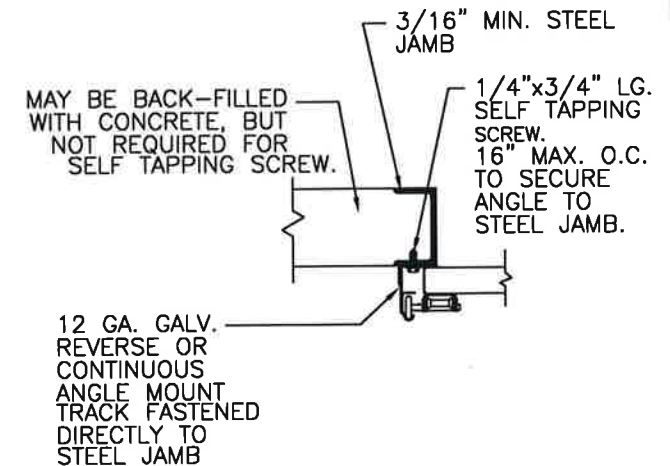

SECTION 3-3

WOOD JAMB ON CONCRETE

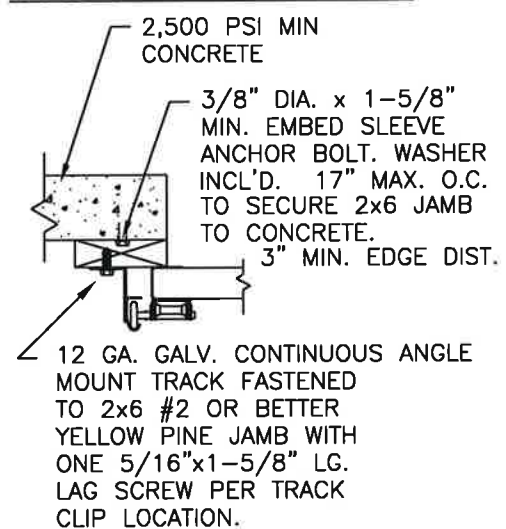

SECTION 3-3

STEEL JAMBS

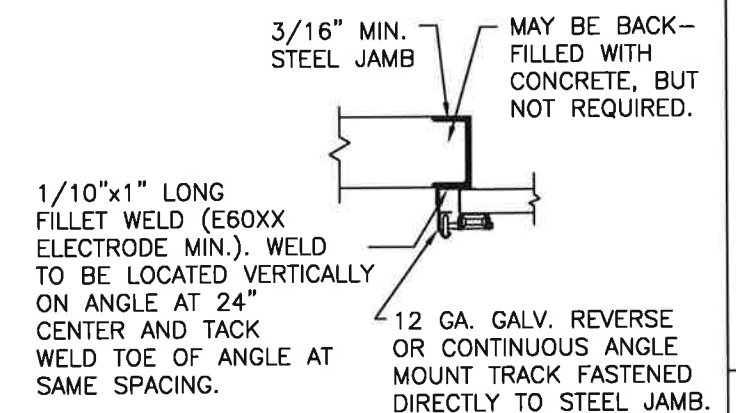

SECTION 3-3



NOTICE: Confidential/Proprietary information of CLOPAY CORPORATION is contained herein and may not be disclosed, used, duplicated, made available, or distributed without its prior consent. Failure to observe this notice may result in liability for any damages and losses resulting therefrom.

Third Angle Projection

Unless Stated Otherwise DIMENSIONS ARE IN INCHES.

Unless Stated Otherwise TOLERANCES are
 .0 = ±.031
 .00 = ±.015
 .000 = ±.005
 .0000 = ±.001
 Degrees = ± 1/2'

Clopay CORPORATION
 8585 Duke Boulevard
 Mason, OH 45040 USA
 Tel. No. 513-770-4800
 Fax No. 513-770-4853

PART NO.: -	CLOPAY WINDLOAD RATING W5
DESCRIPTION: M/N 904 22' WIDE DES. +30/-30 PSF	
DRAWN BY: J. WHEELER	DATE: 4/7/22
CHECKED BY: SH	DATE: CHKD_DT
DWG. NO.: 105624	REV. NO. 00

DESIGN ENGINEER:
 MARK WESTERFIELD, P.E.
 FLORIDA P.E. #48495
 NC P.E. #23832, TEXAS P.E. #91513

Mark Westerfield
 4/21/22

4

3

2

1