

BRAND	MODEL
CLOPAY	904, 904U, AX, AXU
IDEAL	C4AL, C4ALU

THIS PRODUCT COMPLIES WITH THE 2018 IBC/IRC.

REVISIONS					DESCRIPTION
REV. NO.	ZONE	DATE	ECN NO.	APPVD.	
00	-	4/7/20	-	JDW	RELEASED FOR PRODUCTION

MADE FROM 6063-T5 ALUMINUM.

DSB LITES OR BETTER, ANNEALED OR TEMPERED. INSULATED GLAZING SHALL CONSIST OF 2 ANNEALED OR TEMPERED DSB LITES. MAX DLO 20.75" X 25.825".

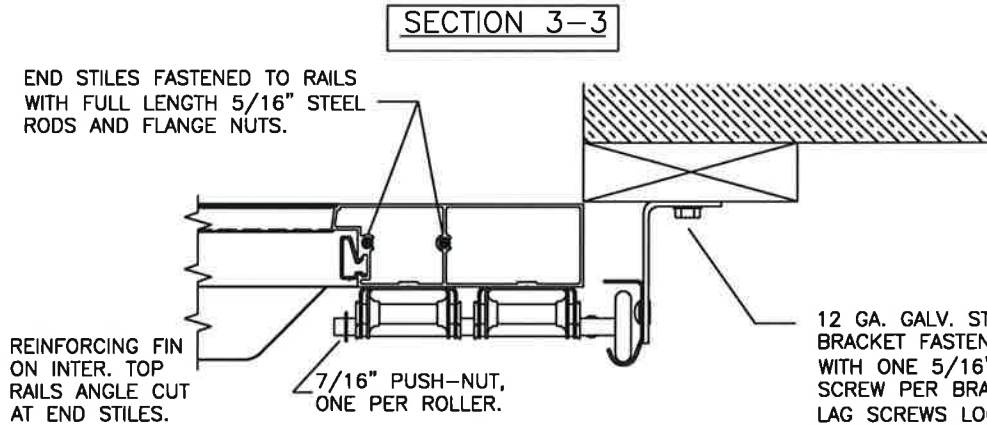
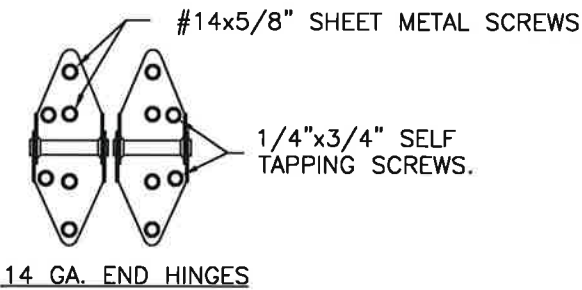
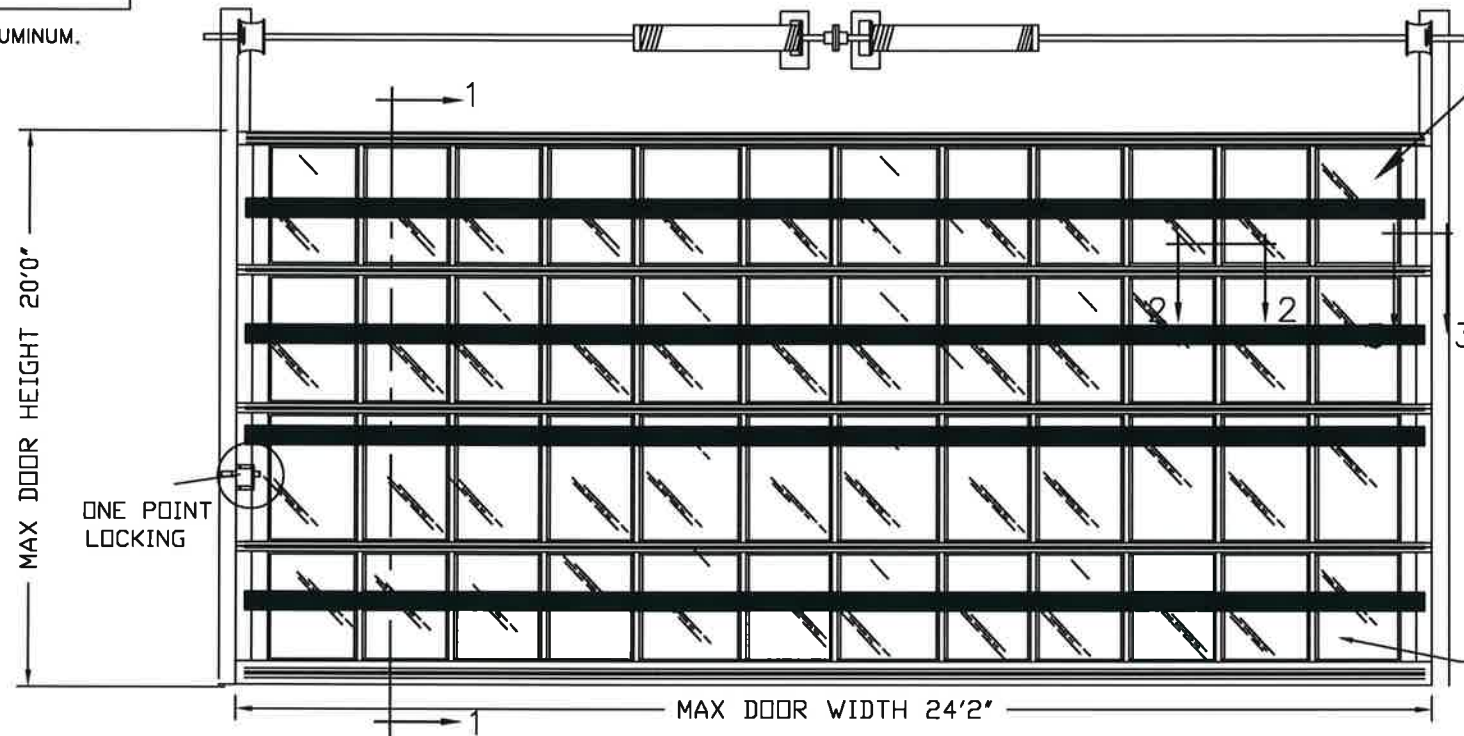

SEE PAGE 2 FOR DIFFERENT JAMB CONFIGURATIONS

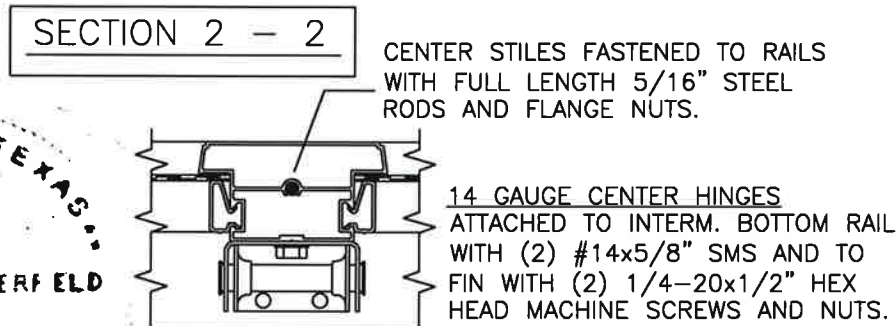

DSB GLAZING OR BETTER. MAX DLO 20.875" X 25.825"

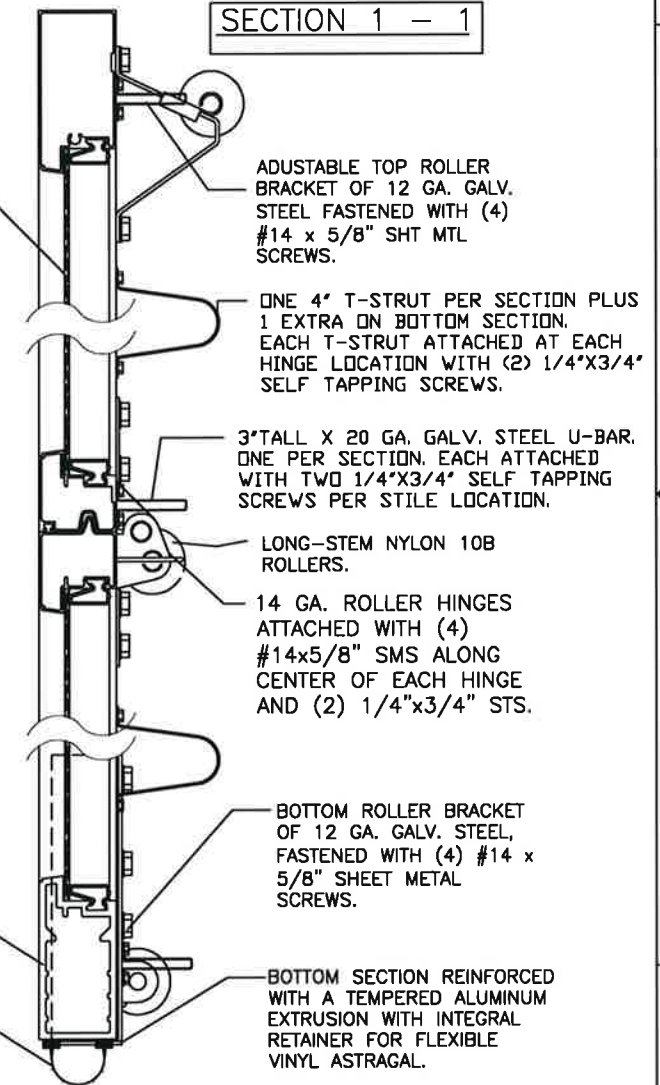

DESIGN PRESSURE: +25.0, -25.0 PSF
TEST PRESSURE: +37.5, -37.5 PSF

Mark Westerfield
4/21/22
STATE OF TEXAS
MARK W. WESTERFIELD
91513
PROFESSIONAL ENGINEER

DESIGN ENGINEER:
MARK WESTERFIELD, P.E.
FLORIDA P.E. #48495
NC P.E. #23832, TEXAS P.E. #91513

MANUFACTURING PRODUCT CODE
C-AL2-1F499

NOTICE:
Confidential/Proprietary information of CLOPAY CORPORATION is contained herein and may not be disclosed, used, duplicated, made available, or distributed without its prior consent. Failure to observe this notice may result in liability for any damages and losses resulting therefrom.

Unless Stated Otherwise TOLERANCES are
.0 = ±.031
.00 = ±.015
.000 = ±.005
.0000 = ±.001
Degrees = ±1/2'

Third Angle Projection

Unless Stated Otherwise DIMENSIONS ARE IN INCHES.

Clopay
CORPORATION

8585 Duke Boulevard
Mason, OH 45040 USA
Tel. No. 513-770-4800
Fax No. 513-770-4853

DESCRIPTION: M/N 904 24' WIDE DES. +25/-25 PSF

DRAWN BY: J. WHEELER DATE: 4/7/20 SCALE: NTS DWG. SIZE B

CHECKED BY: SH DATE: CHKD_DT SHEET 1 OF 2

DWG. NO.: 105620 REV. NO. 00

PART NO.: -
CLOPAY WINDLOAD RATING
W4

4

3

2

1

3" TRACK CONFIGURATION.

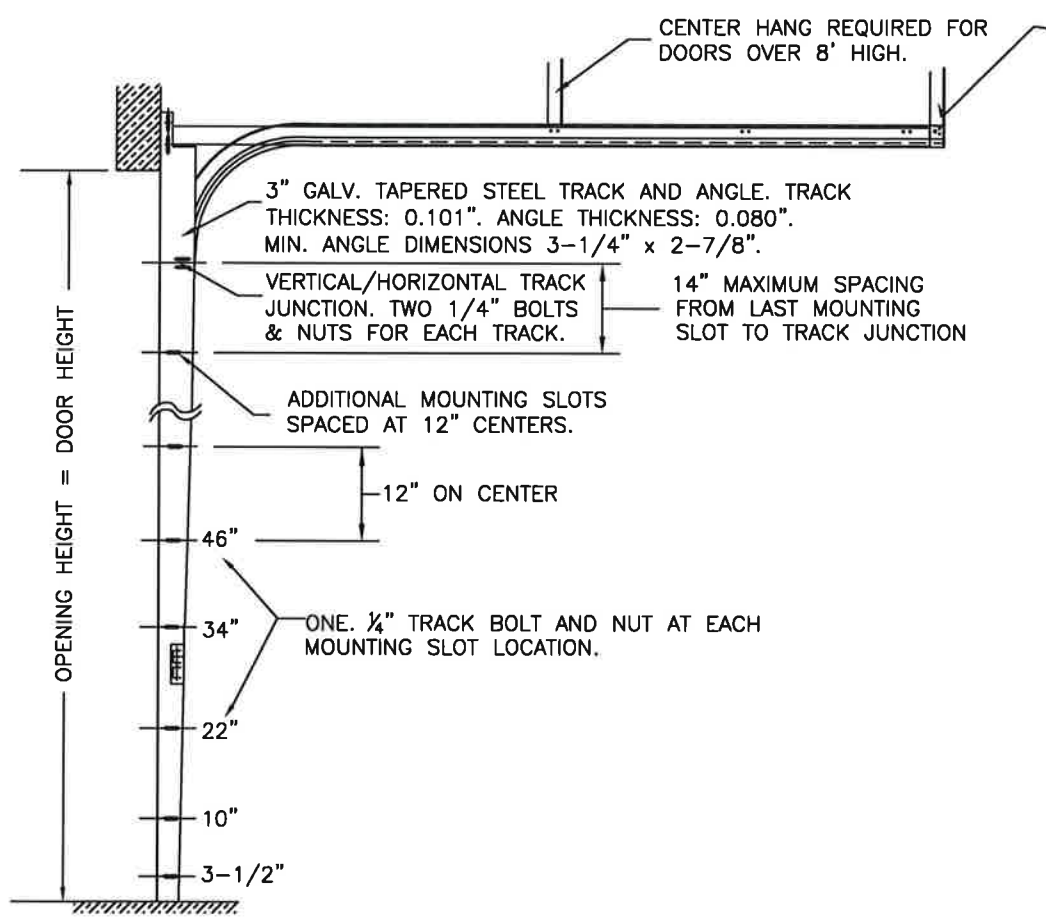

REVISIONS					
REV. NO.	ZONE:	DATE:	ECN NO.	APPVD:	DESCRIPTION
00	-	4/7/22	-	JDW	SEE REVISION HISTORY ON SHEET 1

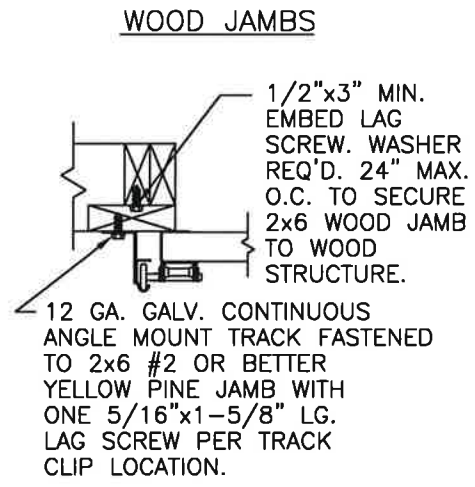

SECTION 3-3

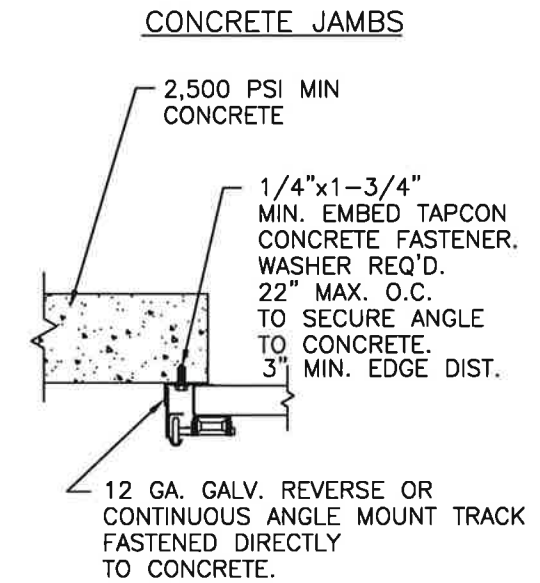

SECTION 3-3

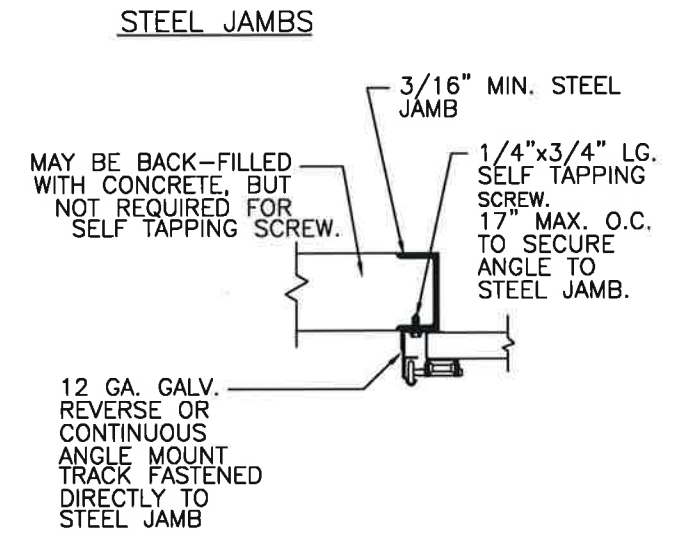

SECTION 3-3

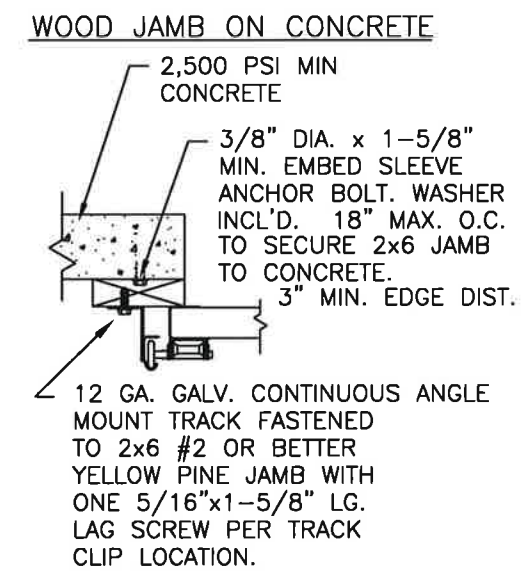

SECTION 3-3

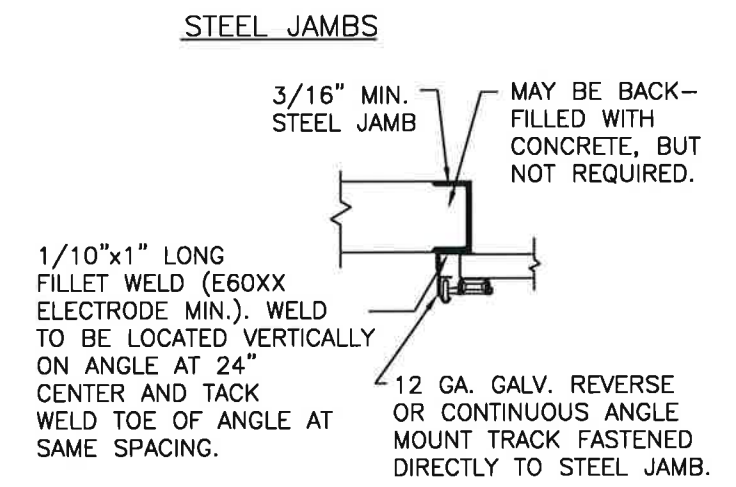

SECTION 3-3

DOOR HEIGHT	VERTICAL TRACK LENGTH
7'-0"	72"
8'-0"	84"
9'-0"	96"
10'-0"	108"
12'-0"	132"
14'-0"	156"
16'-0"	180"
17'-0"	204"
18'-0"	228"
19'-0"	252"
20'-0"	276"

NOTE DOUBLE TRACK HEADROOM, HI-LIFT TRACK, FOLLOW-THE-ROOF TRACK, AND VERTICAL LIFT TRACK ARE AVAILABLE OPTIONS. TRACK CONFIGURATION ABOVE THE DOOR OPENING DOES NOT AFFECT THE WIND LOAD RATING.

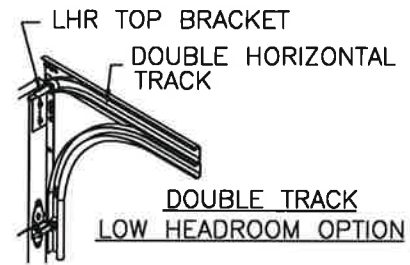

Mark Westerfeld
4/21/22

DESIGN ENGINEER:
MARK WESTERFIELD, P.E.
FLORIDA P.E. #48495
NC P.E. #23832, TEXAS P.E. #91513

<p>NOTICE:</p> <p>Confidential/Proprietary information of CLOPAY CORPORATION is contained herein and may not be disclosed, used, duplicated, made available, or distributed without its prior consent. Failure to observe this notice may result in liability for any damages and losses resulting therefrom.</p>	<p>Unless Stated Otherwise TOLERANCES are</p> <p>.0 = ±.031</p> <p>.00 = ±.015</p> <p>.000 = ±.005</p> <p>.0000 = ±.001</p> <p>Degrees = ±1/2'</p>	<p>Third Angle Projection</p>	<p>Unless Stated Otherwise DIMENSIONS ARE IN INCHES.</p>

PART NO.: -			
CLOPAY WINDLOAD RATING			
W4			
DESCRIPTION: M/N 904 24' WIDE DES. +25/-25 PSF			
DRAWN BY: J. WHEELER	DATE: 4/7/22	SCALE: NTS	DWG. B
CHECKED BY: SH	DATE: CHKD_DT	SHEET 2 OF 2	SIZE B
DWG. NO.: 105620		REV. NO. 00	

4

3

2

1