



215 EAST ROOSEVELT AVE.
ZEELAND, MI 49464

Distributed by: ProBuild Company, LLC
302 North Mile 2-1/2 East
Mercedes, TX 78570

FIBERGLASS ENTRY DOOR IN SWING / OUT SWING "IMPACT"

EVALUATED FOR USE IN THE STATE OF TEXAS

The Fiberglass Glazed Door described herein complies with the 2006 International Residential Code (IRC), Sections R301 & R613 and the 2006 International Building Code (IBC), Sections 1405.12, 1609, 1714.5, 2403 and 2404 (including Texas revisions) subject to the following conditions:

1. Anchors shall be as listed and spaced as shown in the details. Anchor embedment to base material shall be beyond wall dressing or stucco.
2. This system has been tested and evaluated as a large missile impact protective system for installation in the Seaward, Inland I and Inland II areas. This product meets missile level "D" as defined in ASTM E 1996.
3. Allowable design pressure requirements must be equal to or less than the design pressure rating shown in the design pressure chart, sheet 1 of this drawing.
4. Conditions not covered by this drawing are subject to further engineering analysis.

TABLE OF CONTENTS

SHEET #	DESCRIPTION
1	Typical elevations, design pressures & general notes
2	Door/Sidelite panel details
3	Lite frame and glazing details
4	Elevations
5	Horizontal cross sections
6	Vertical cross sections
7	Vertical cross sections
8	Frame anchoring
9	Astragal details
10	Bill of materials & components

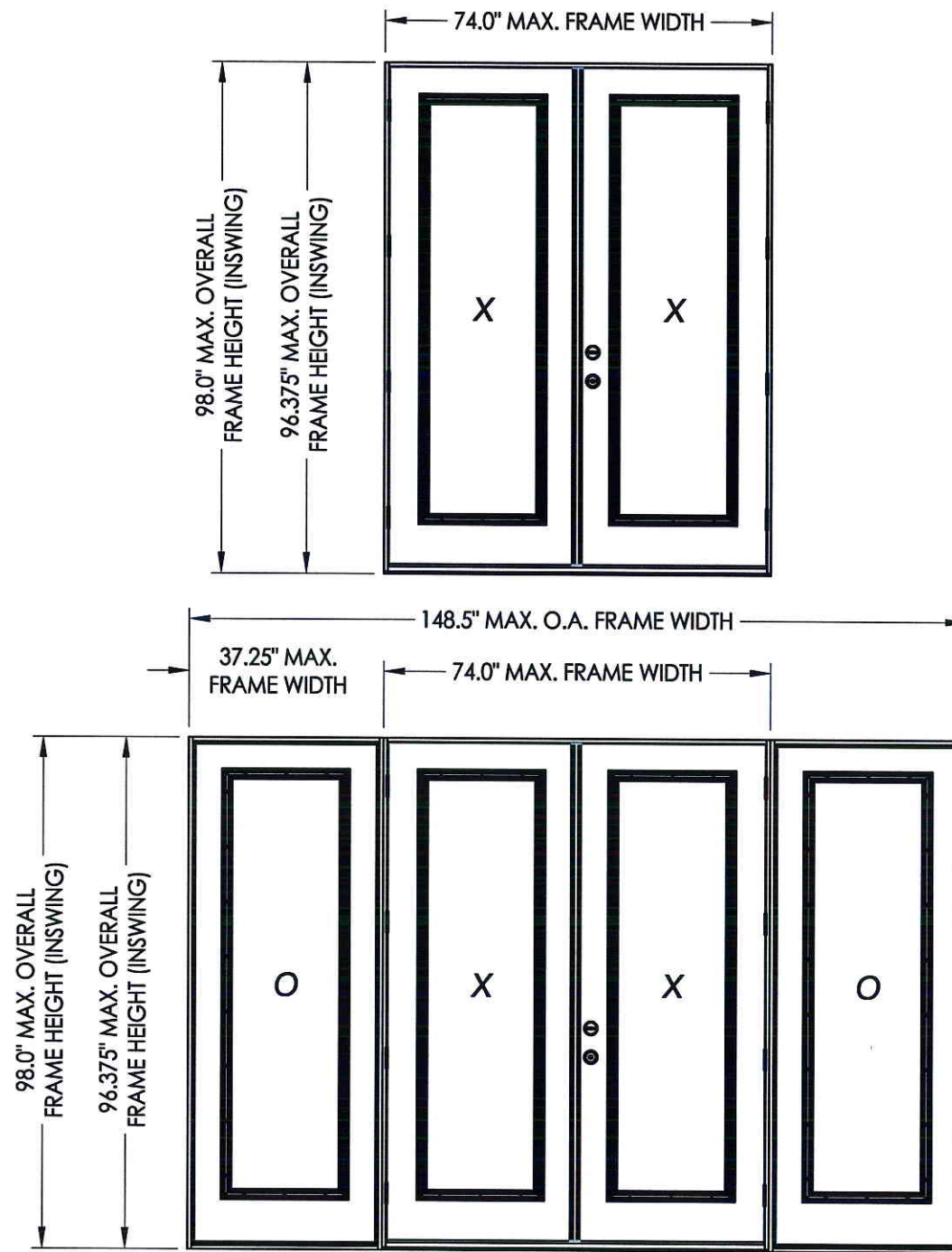

CONFIGURATION	MAX. FRAME DIMENSION	DESIGN PRESSURE (PSF) INSWING		DESIGN PRESSURE (PSF) OUTSWING	
		POSITIVE	NEGATIVE	POSITIVE	NEGATIVE
XX	74.0" x 98.0"	+35.0	-40.0	+35.0	-35.0
OXXO	148.5" x 98.0"	+35.0	-40.0	+35.0	-35.0

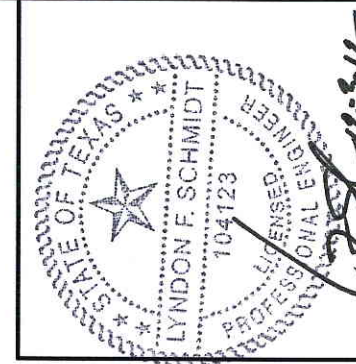

Documents Prepared By: Lyndon F. Schmidt, P.E.
TEXAS P.E. #104123

RW BUILDING CONSULTANTS, INC.
P.O. Box 230 Vairco FL 33595
Phone No.: 813.659.9197

TEXAS BOARD OF PROFESSIONAL ENGINEERS
CERTIFICATE OF REGISTRATION # F-11852

PRODUCT:	FIBERGLASS DOOR
PART OR ASSEMBLY:	TYPICAL ELEVATION, DESIGN PRESSURES & GENERAL NOTES
DATE:	11/8/12
SCALE:	N.T.S.
DWG. BY:	JK
CHK. BY:	LFS
DRAWING NO.:	TX-4279
SHEET	1 OF 10

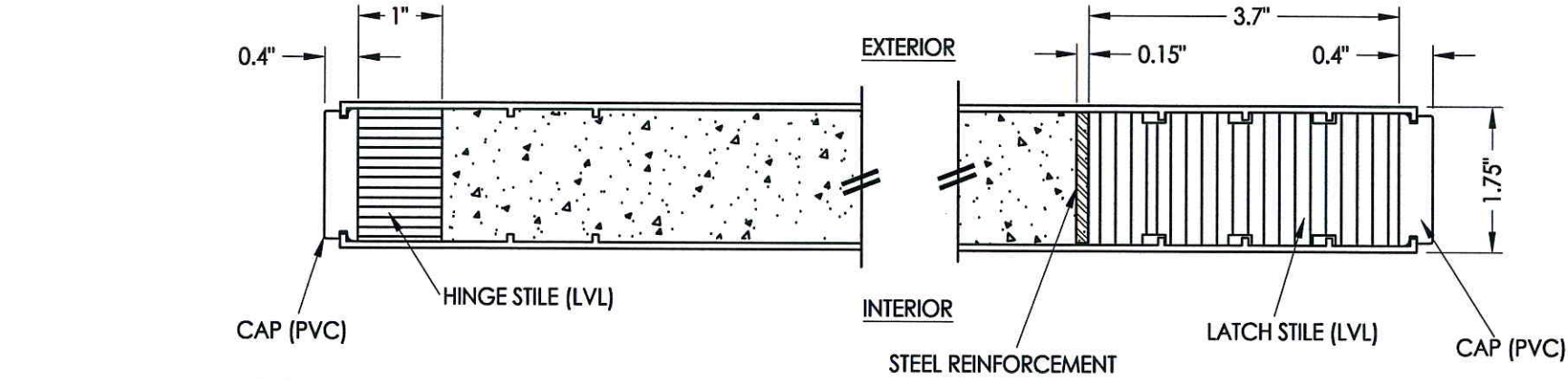

1
2 HORIZONTAL CROSS SECTION

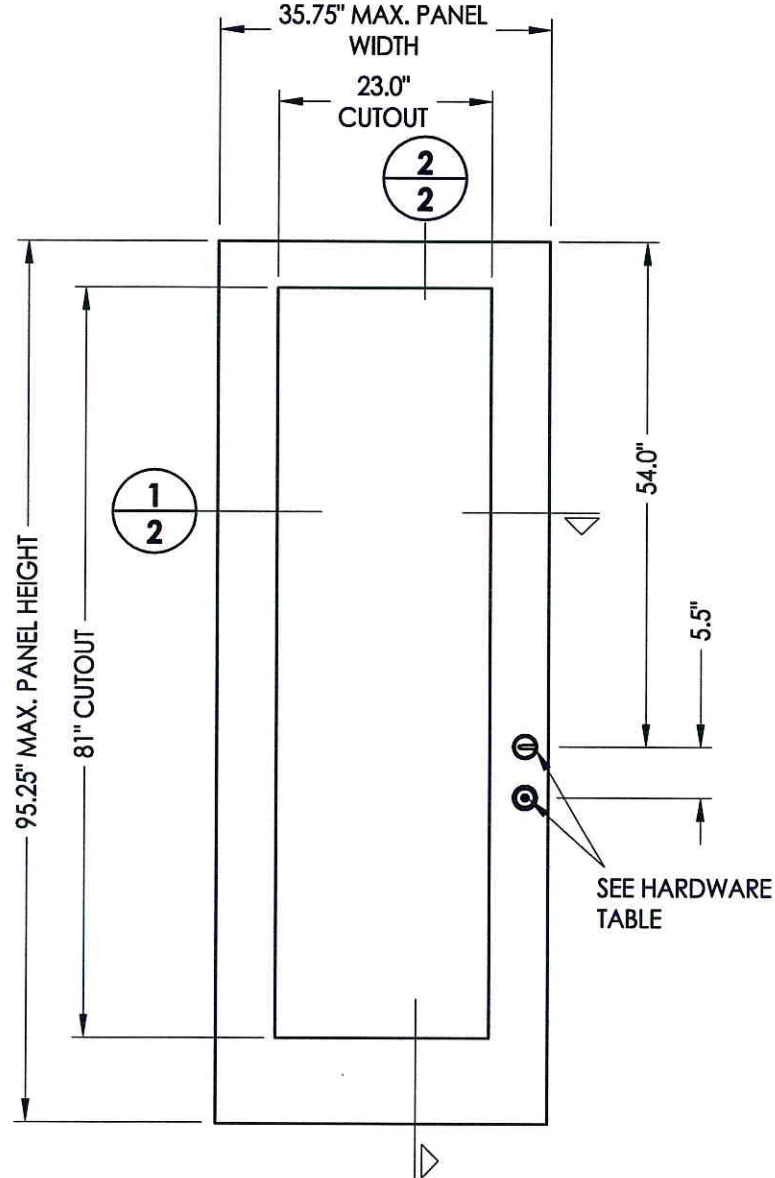

40 DOOR PANEL
Fiberglass (Plastpro)

50 SIDELITE PANEL
Fiberglass (Plastpro)

SEE HARDWARE TABLE

HARDWARE TABLE		
MANUFACTURER	MODEL	
KWIKSET	KNOB: DEADBOLT:	SIGNATURE SERIES SIGNATURE SERIES (980)

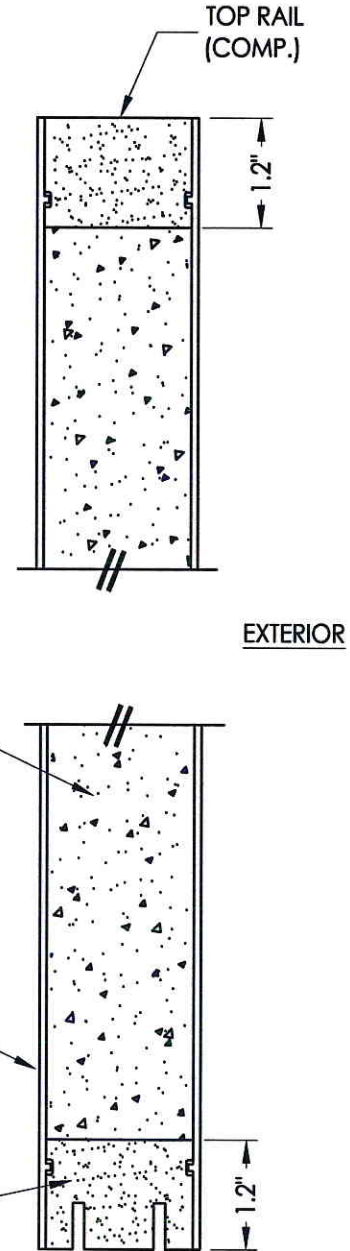

2
2 VERTICAL CROSS SECTION



Documents Prepared By: Lyndon F. Schmidt, P.E.
TEXAS P.E. #104123

R.W. BUILDING CONSULTANTS, INC.
P.O. Box 230 Valrico FL 33595
Phone No.: 813.659.9197
TEXAS BOARD OF PROFESSIONAL ENGINEERS
CERTIFICATE OF REGISTRATION # F-11852

PRODUCT: FIBERGLASS DOOR
PART OR ASSEMBLY: DOOR/SIDELITE PANEL DETAILS

NO.	DATE	BY	REVISIONS

DATE: 11/8/12
SCALE: N.T.S.
DWG. BY: JK
CHK. BY: LFS
DRAWING NO.: TX-4279
SHEET 2 OF 10

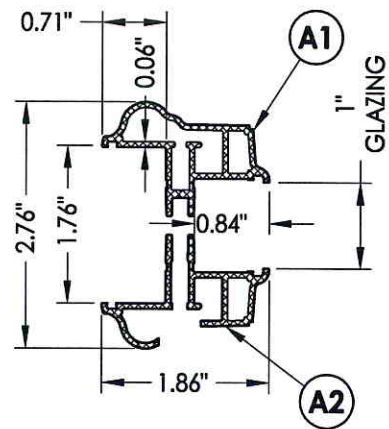

ODL LITE FRAME CROSS SECTION
1" GLAZING

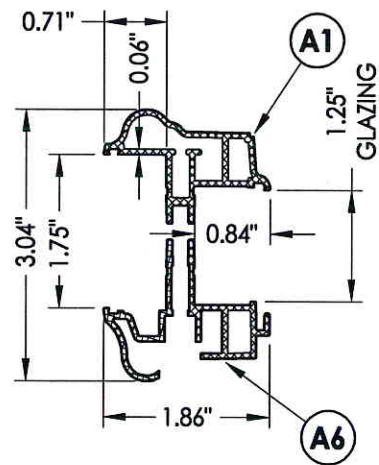

ODL LITE FRAME CROSS SECTION
1.25" GLAZING

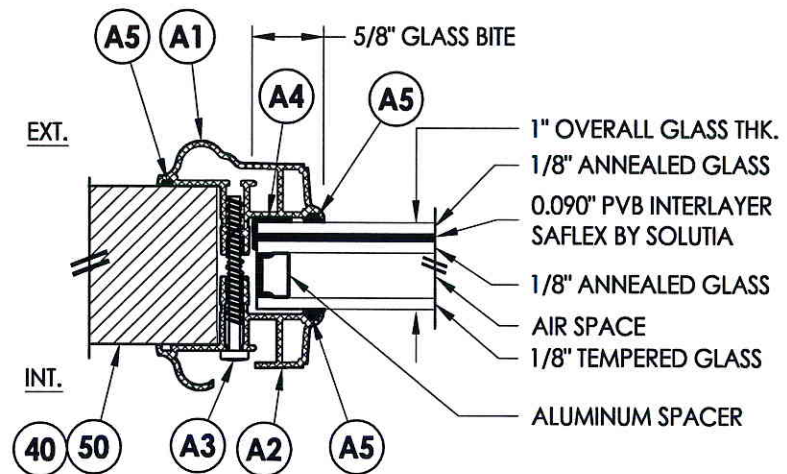

G1 GLAZING DETAIL

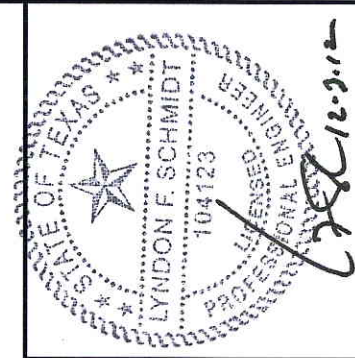

Documents Prepared By: Lyndon F. Schmidt, P.E.
TEXAS P.E. #104123

RW BUILDING CONSULTANTS, INC.
P.O. Box 230 Vairco FL 33595
Phone No.: 813.659.9197

TEXAS BOARD OF PROFESSIONAL ENGINEERS
CERTIFICATE OF REGISTRATION # F-11852

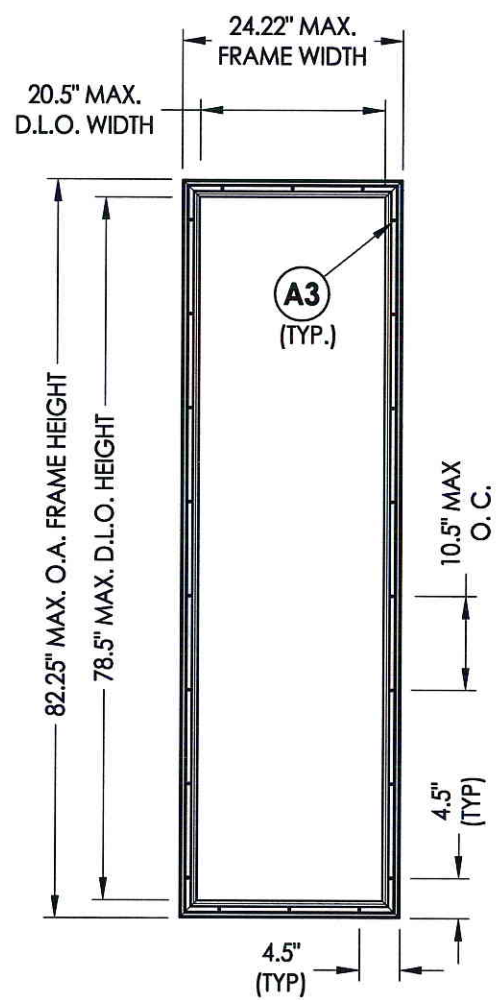

ODL LITE FRAME

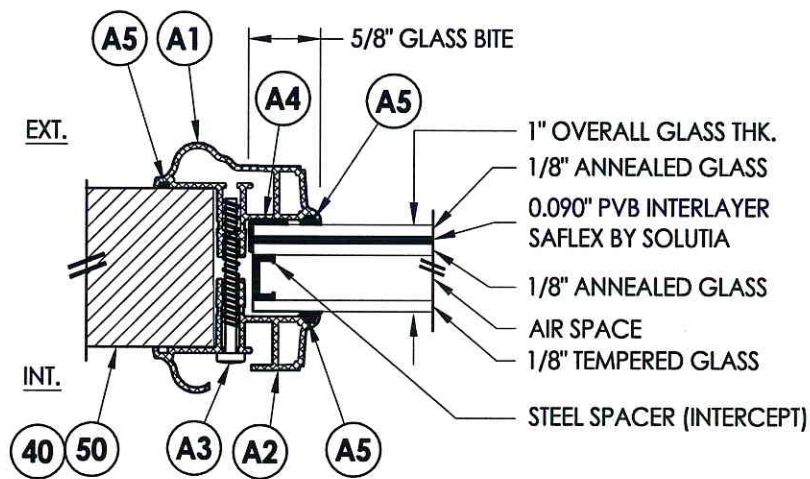

G2 GLAZING DETAIL

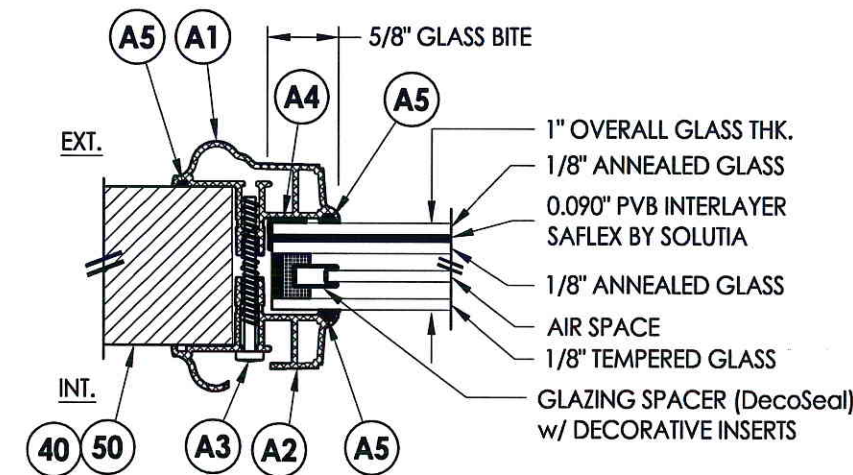

G3 GLAZING DETAIL

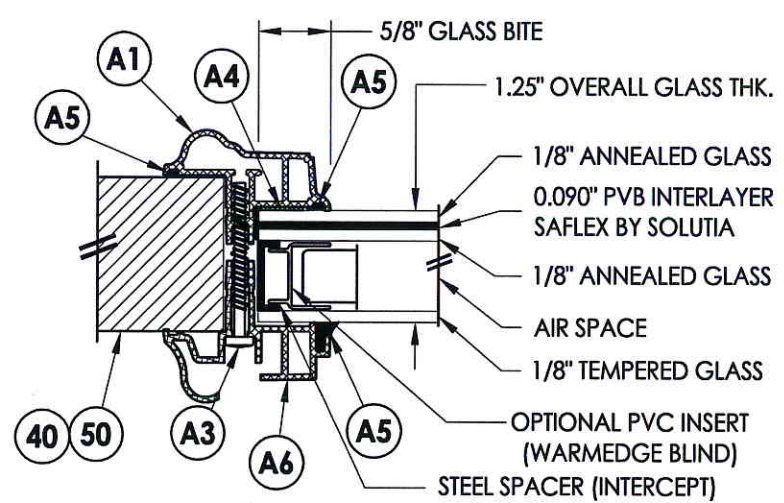

G4 GLAZING DETAIL

MAX. DESIGN PRESSURE FOR G4 GLAZING
INSWING = +30/-30 PSF
OUTSWING = +30/-30 PSF

BILL OF MATERIALS (LITE FRAME & GLAZING DETAILS)

ITEM #	DESCRIPTION	MATERIAL
A1	EXTERIOR FRAME	ALUM.
A2	INTERIOR FRAME (1" GLAZING)	ALUM.
A3	#7-19 X 1-3/4" PPH SELF-DRILLING SMS	STEEL
A4	DOW 995 STRUCTURAL SILICONE	SILICONE
A5	NON STRUCTURAL BACKBEDDING SEALANT (READISEAL)	-
A6	INTERIOR FRAME (1" GLAZING)	ALUM.

PRODUCT: FIBERGLASS DOOR
PART OR ASSEMBLY: LITE FRAME & GLAZING DETAILS

NO.	DATE	BY	REVISIONS

DATE: 11/8/12
SCALE: N.T.S.
DWG. BY: JK
CHK. BY: LFS
DRAWING NO.: TX-4279
SHEET 3 OF 10

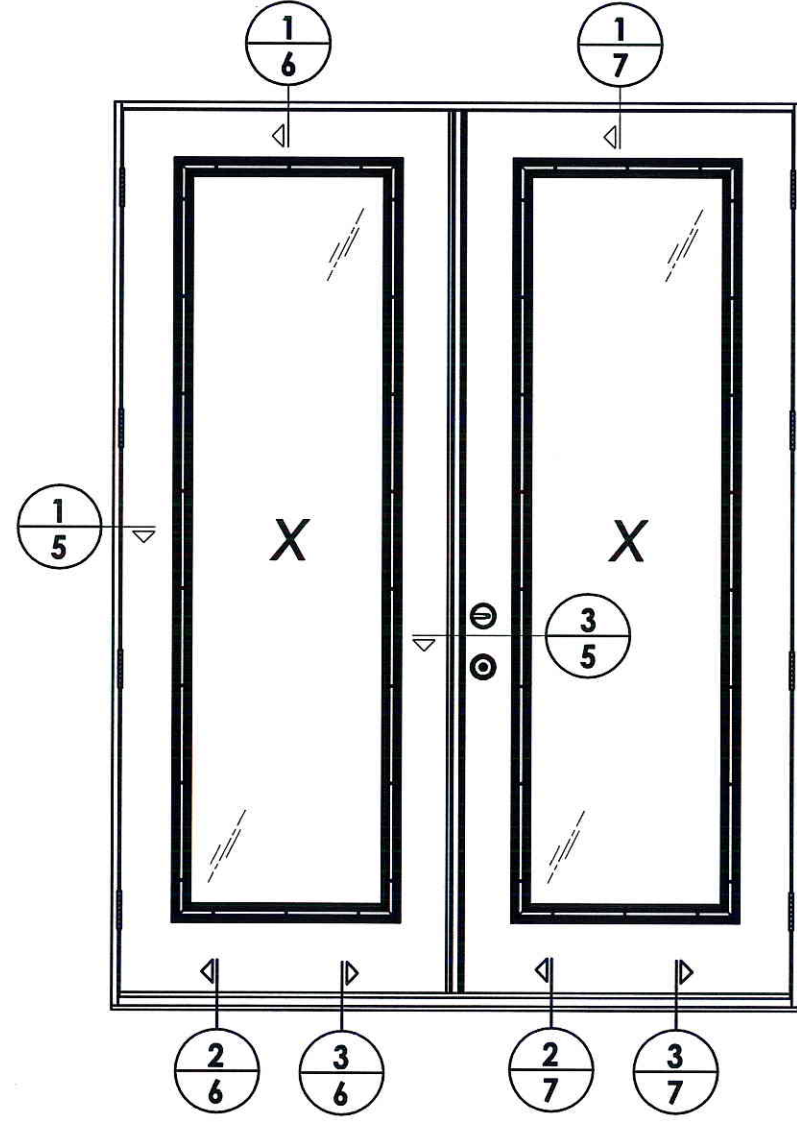

ELEVATION
XX

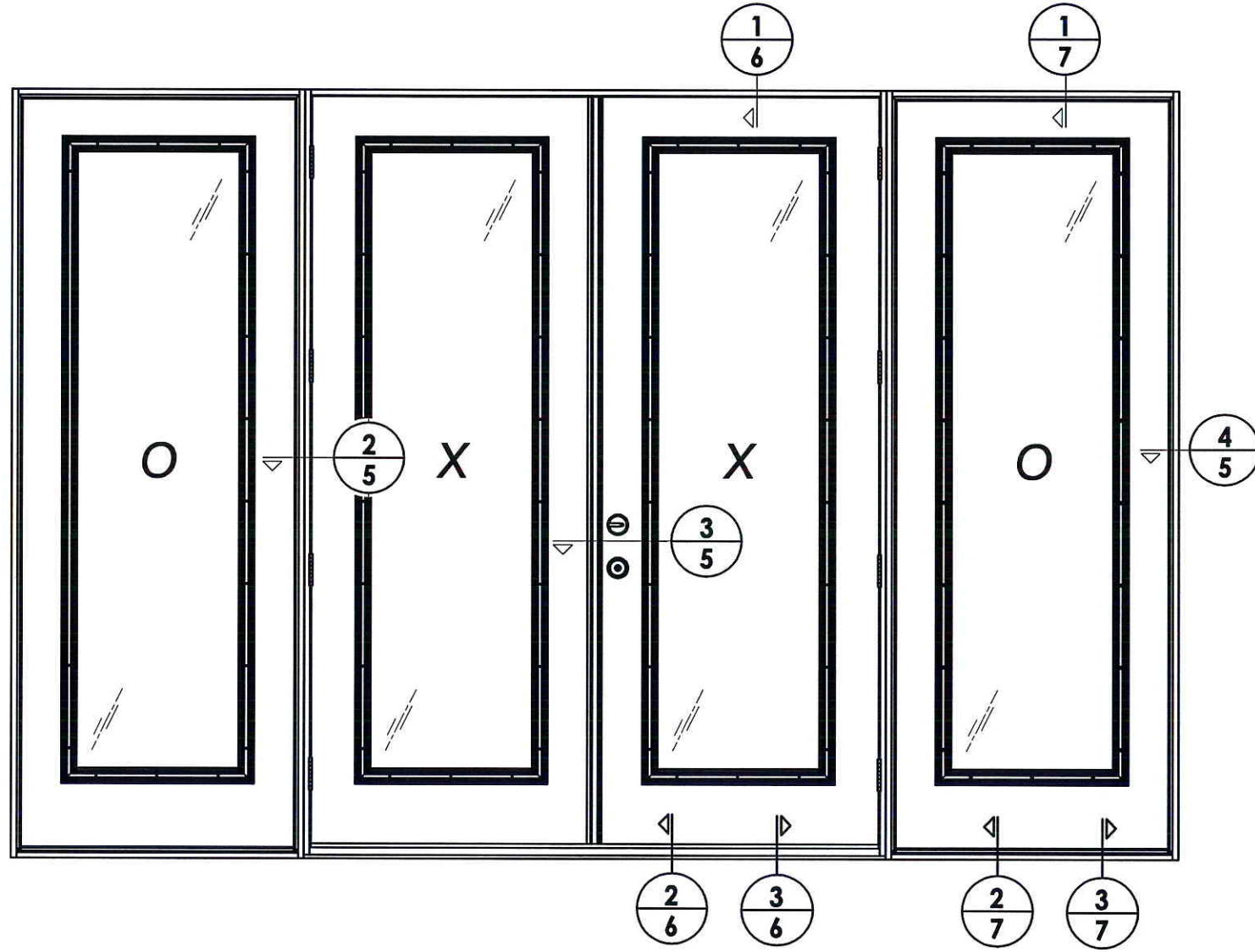

ELEVATION
OXXO

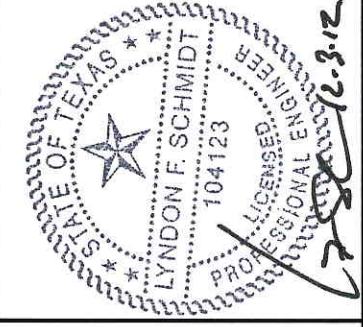

Documents Prepared By: Lyndon F. Schmidt, P.E.
TEXAS P.E. #104123

RW BUILDING CONSULTANTS, INC.
P.O. Box 230 Valrico FL, 33595
Phone No.: 813.658.9197

TEXAS BOARD OF PROFESSIONAL ENGINEERS
CERTIFICATE OF REGISTRATION # F-11852

PRODUCT:		FIBERGLASS DOOR	
PART OR ASSEMBLY:		ELEVATIONS	
NO.	DATE	BY	REVISIONS
DATE: 11/8/12			
SCALE: N.T.S.			
DWG. BY: JK			
CHK. BY: LFS			
DRAWING NO.:			
TX-4279			
SHEET 4 OF 10			

R:\A - Projects\Project Folders\Proj 1601 - 1700\PF 1676\D. RWBC Drawings\TX-4278-79.dwg, 5.2

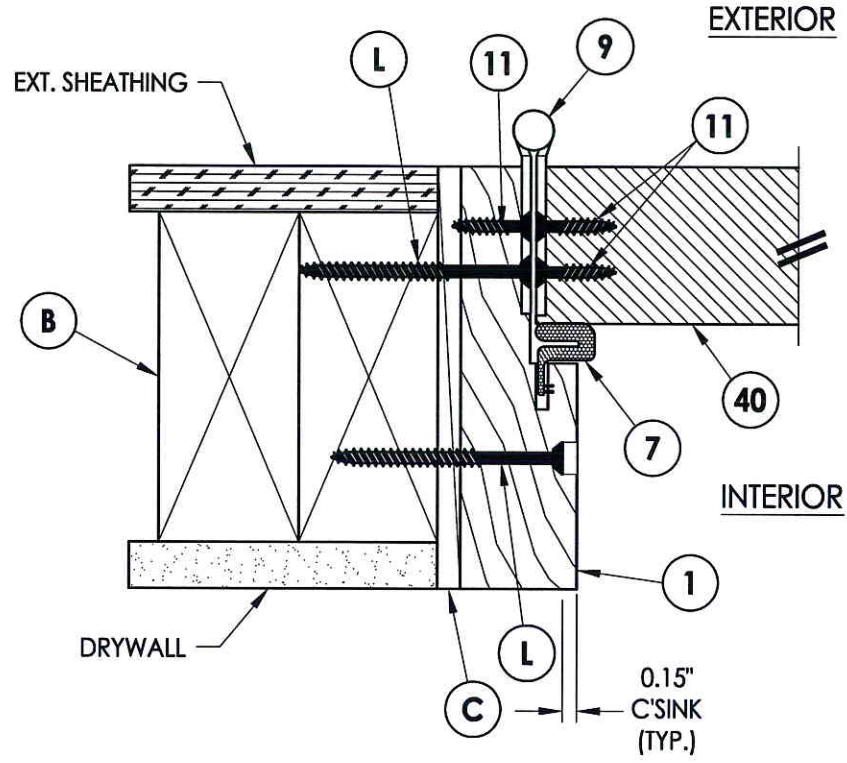

1 HORIZONTAL CROSS SECTION
5 Outswing shown - inswing also approved

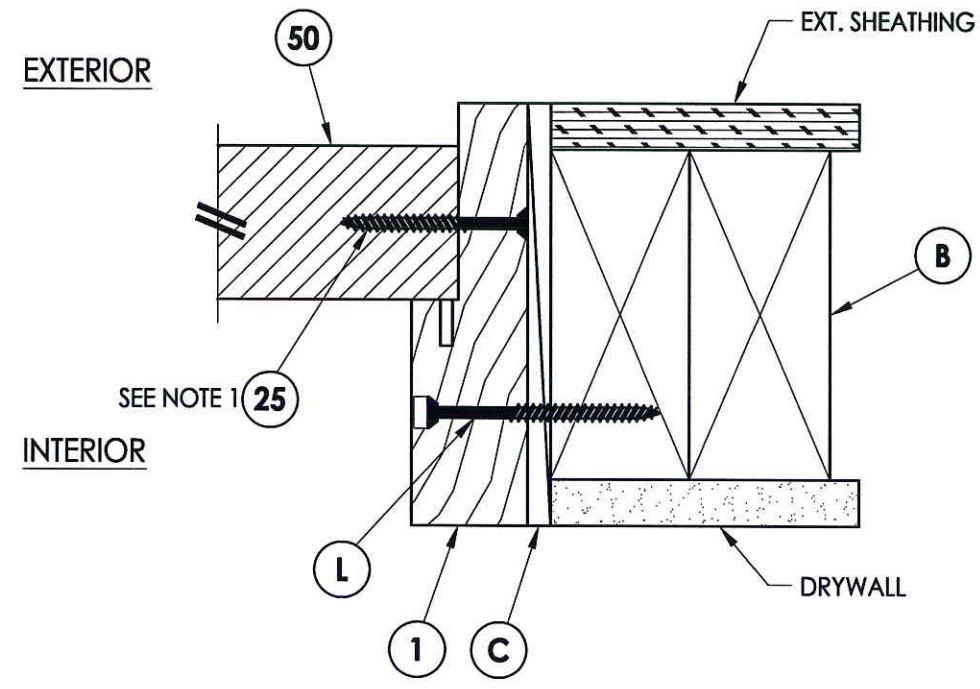

4 HORIZONTAL CROSS SECTION
5 Outswing shown - Inswing also approved

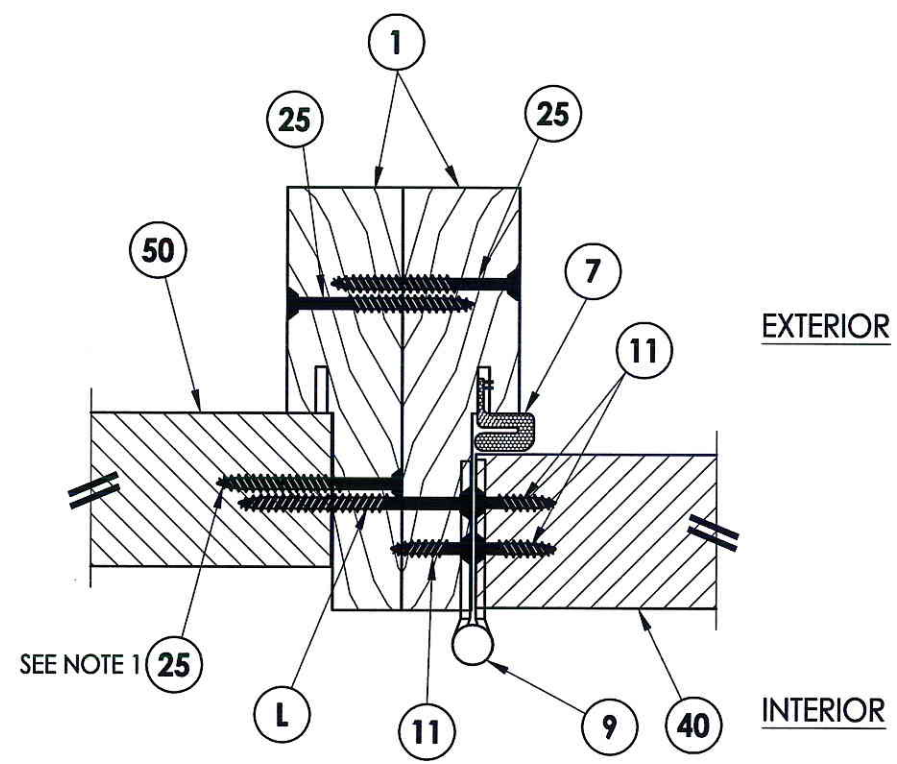

2 HORIZONTAL CROSS SECTION
5 Inswing shown - outswing also approved

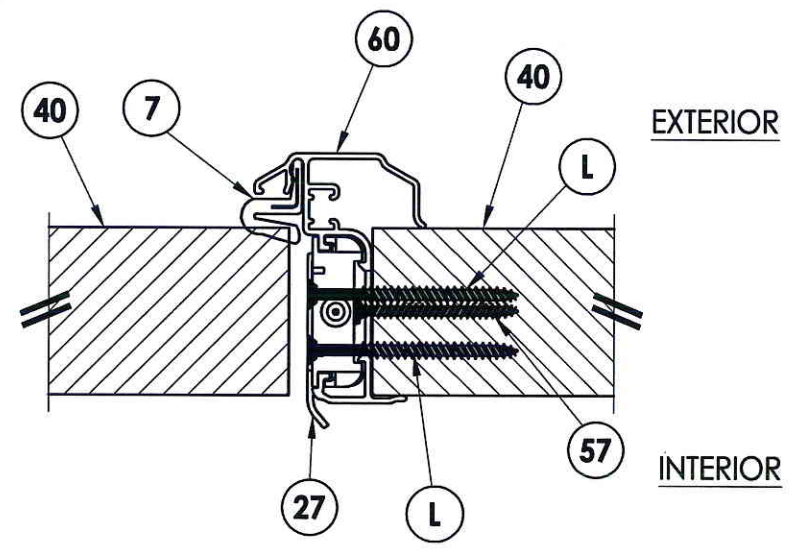

3 HORIZONTAL CROSS SECTION
5 Inswing shown - outswing also approved

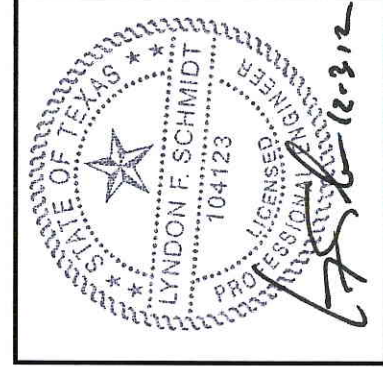

NOTE:
 1. Sidelite panel screws located 6" from each end plus 5 more equally spaced (7 screws total).

Documents Prepared By: Lyndon F. Schmidt, P.E.
 TEXAS P.E. #104123

RW BUILDING CONSULTANTS, INC.
 P.O. Box 230 Valrico FL, 33595
 Phone No.: 813.659.9197

TEXAS BOARD OF PROFESSIONAL ENGINEERS
 CERTIFICATE OF REGISTRATION # F-11852

PRODUCT: FIBERGLASS DOOR
 PART OR ASSEMBLY: HORIZONTAL CROSS SECTIONS

NO.	DATE	BY

DATE: 11/8/12
 SCALE: N.T.S.
 DWG. BY: JK
 CHK. BY: LFS
 DRAWING NO.: TX-4279
 SHEET 5 of 10

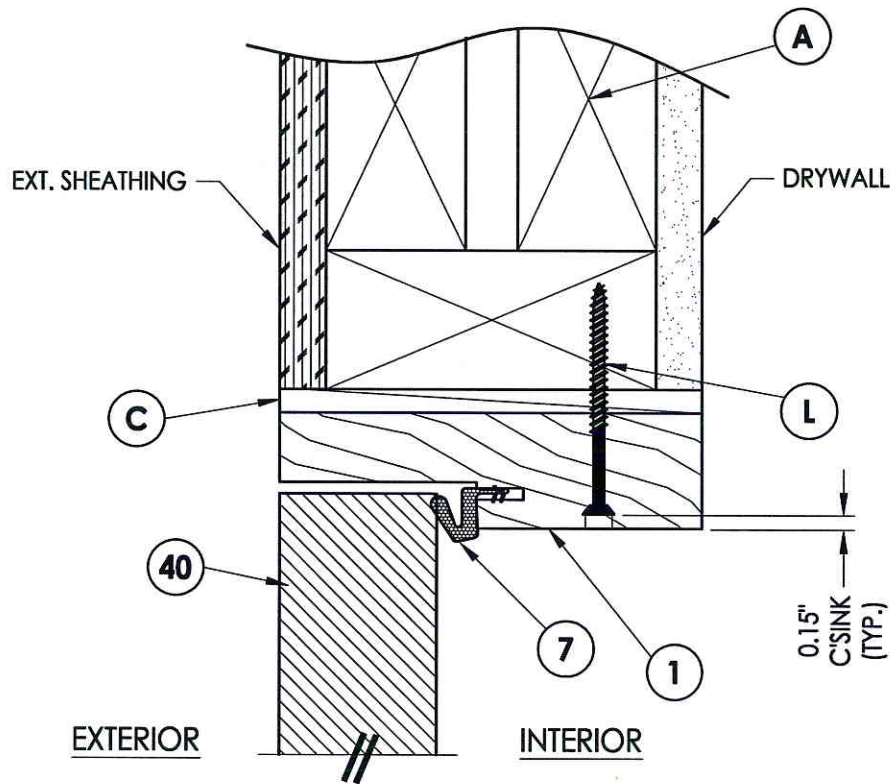

1 VERTICAL CROSS SECTION
6 Outswing shown - inswing also approved

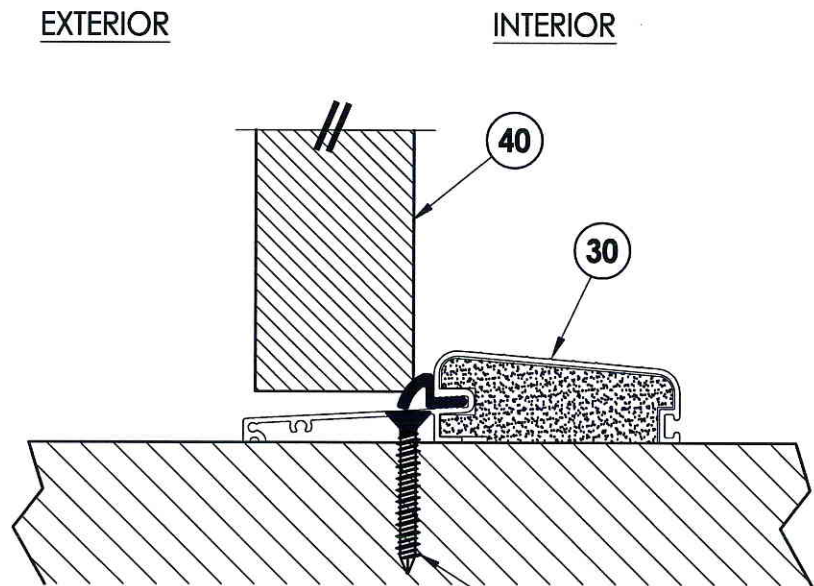

2 VERTICAL CROSS SECTION
6 Outswing configuration

J WOOD
D CONCRETE

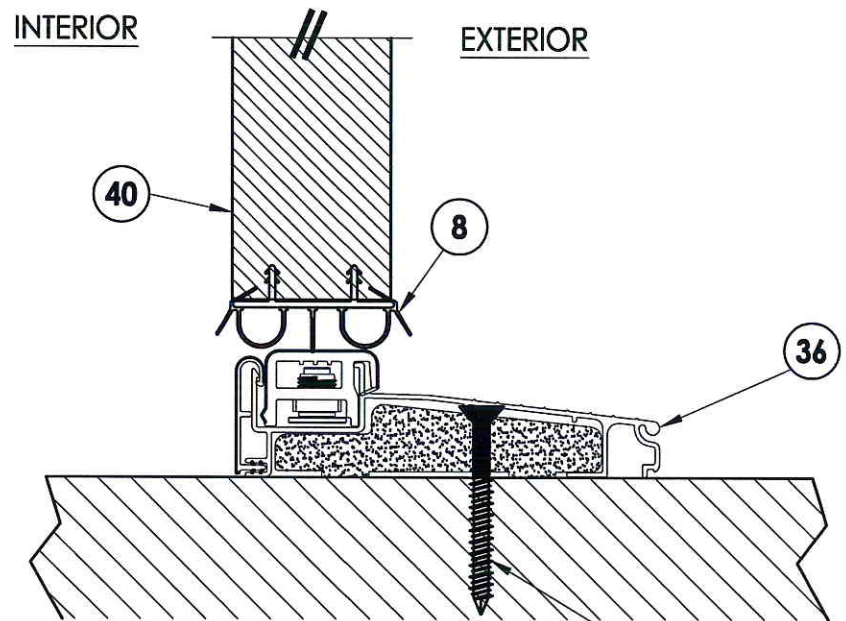

3 VERTICAL CROSS SECTION
6 Inswing configuration

J WOOD
D CONCRETE

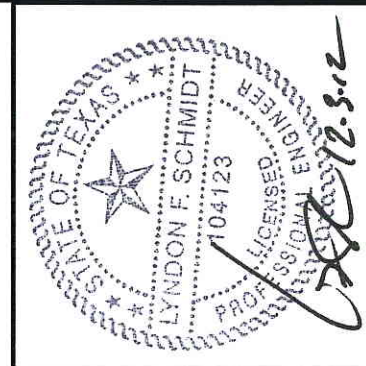

Documents Prepared By: Lyndon F. Schmidt, P.E.
 TEXAS P.E. #104123

RW BUILDING CONSULTANTS, INC.
 P.O. Box 230 Valrico FL, 33595
 Phone No.: 813.669.9197

TEXAS BOARD OF PROFESSIONAL ENGINEERS
 CERTIFICATE OF REGISTRATION # F-11852

PRODUCT: FIBERGLASS DOOR
 PART OR ASSEMBLY: VERTICAL CROSS SECTIONS

NO.	DATE	BY	REVISIONS

DATE: 11/8/12
 SCALE: N.T.S.
 DWG. BY: JK
 CHK. BY: LFS
 DRAWING NO.: TX-4279
 SHEET 6 OF 10

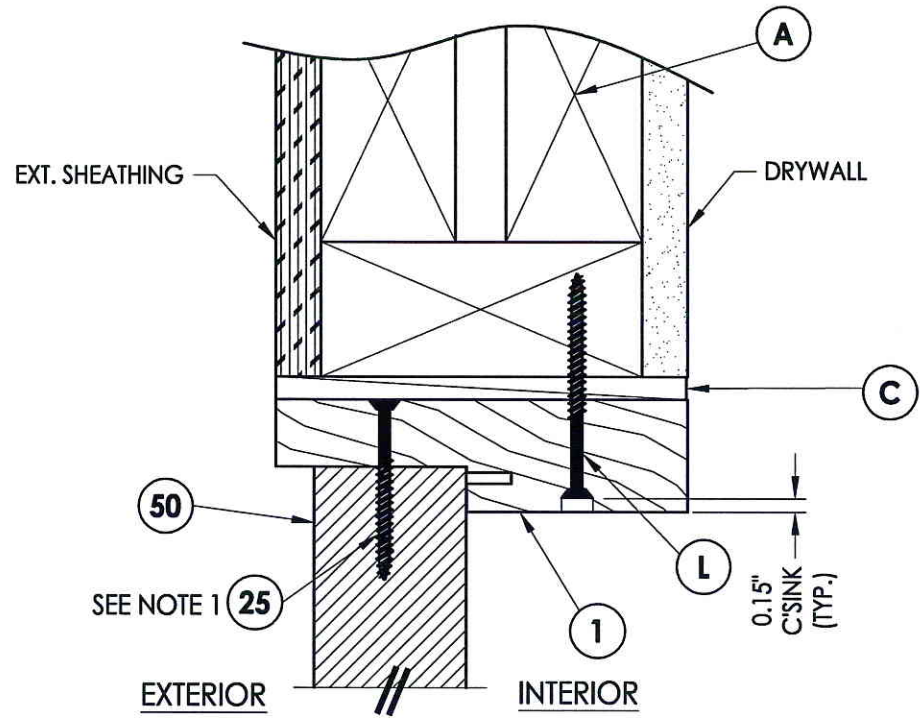

1
7 VERTICAL CROSS SECTION
Outswing shown - Inswing also approved

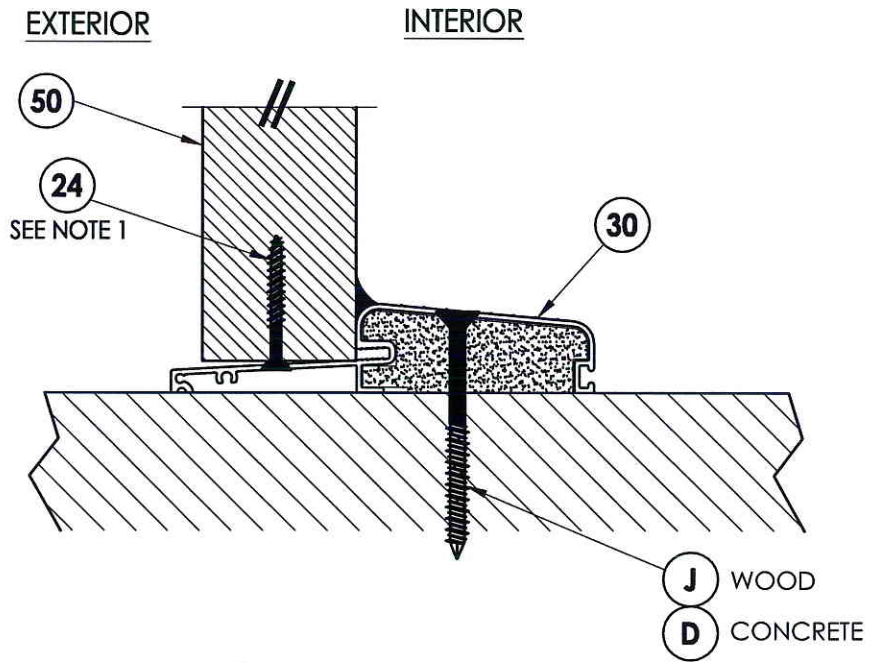

2
7 VERTICAL CROSS SECTION
Outswing shown

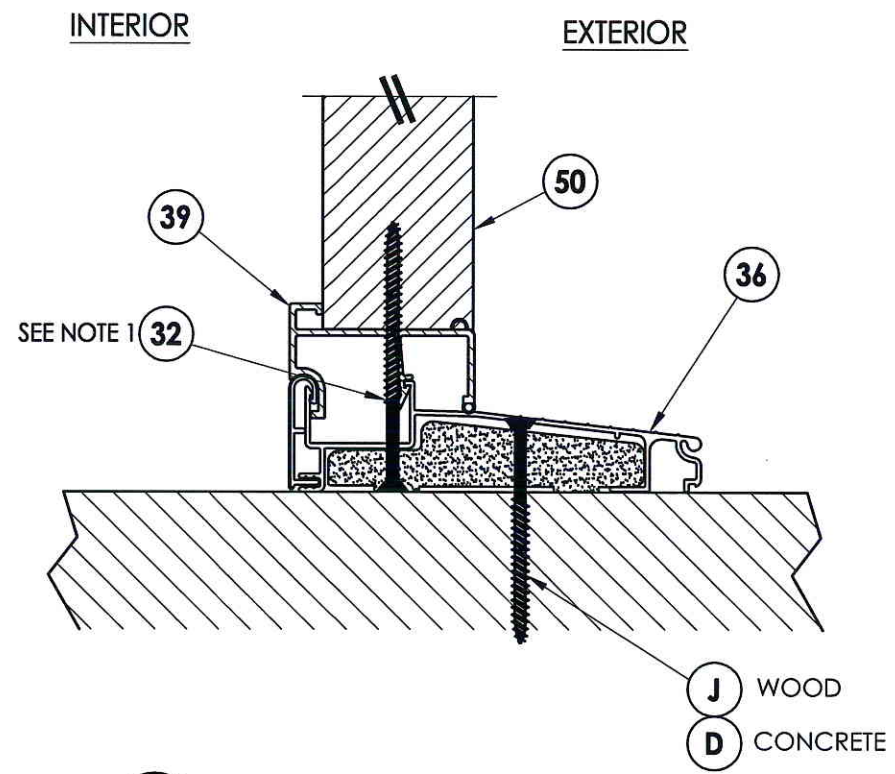

3
7 VERTICAL CROSS SECTION
Inswing shown



NOTE:
1. Sidelite panel screws located 6" from each end (2 Total).

Documents Prepared By: Lyndon F. Schmidt, P.E.
TEXAS P.E. #104123

RW BUILDING CONSULTANTS, INC.
P.O. Box 230 Vairico FL 33595
Phone No.: 813.659.9197
TEXAS BOARD OF PROFESSIONAL ENGINEERS
CERTIFICATE OF REGISTRATION # F-11852

PRODUCT:	FIBERGLASS DOOR	
PART OR ASSEMBLY:	VERTICAL CROSS SECTIONS	
NO.	DATE	BY
REVISIONS		
DATE: 11/8/12		
SCALE: N.T.S.		
DWG. BY: JK		
CHK. BY: LFS		
DRAWING NO.: TX-4279		
SHEET 7 OF 10		

R:\A - Projects\Project Folders\Proj 1601 - 1700\PF 1676\D. RWBC Drawings\TX-4278-79.dwg, 8.2

2X FRAMING TO BE DESIGNED BY THE ENGINEER OR ARCHITECT OF RECORD BASED ON WIND LOADS AND THE CLADDING BEING USED (TYP).

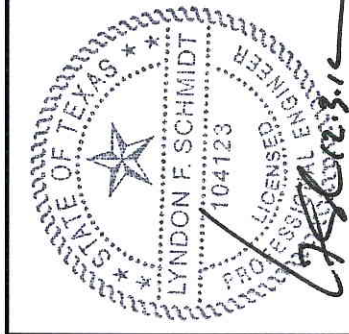

Documents Prepared By: Lyndon F. Schmidt, P.E.
TEXAS P.E. #104123

RW BUILDING CONSULTANTS, INC.
P.O. Box 230 Vairico FL 33595
Phone No.: 813.659.9197

TEXAS BOARD OF PROFESSIONAL ENGINEERS
CERTIFICATE OF REGISTRATION # F-11852

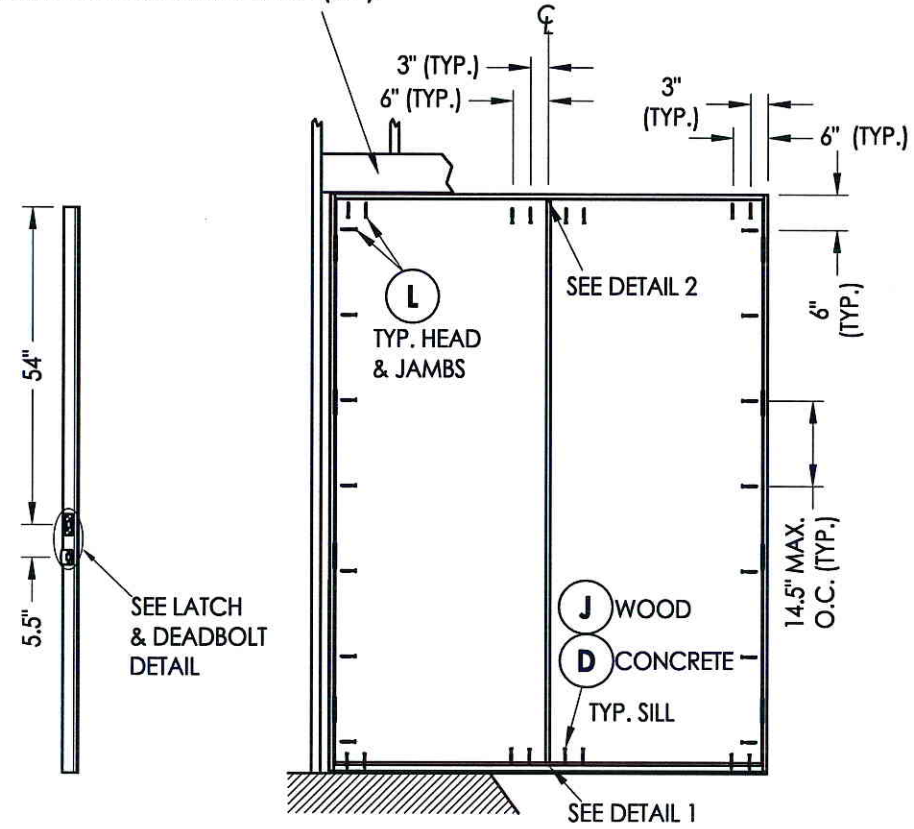

ASTRAGAL STRIKE

**FRAME ANCHORING
XX**

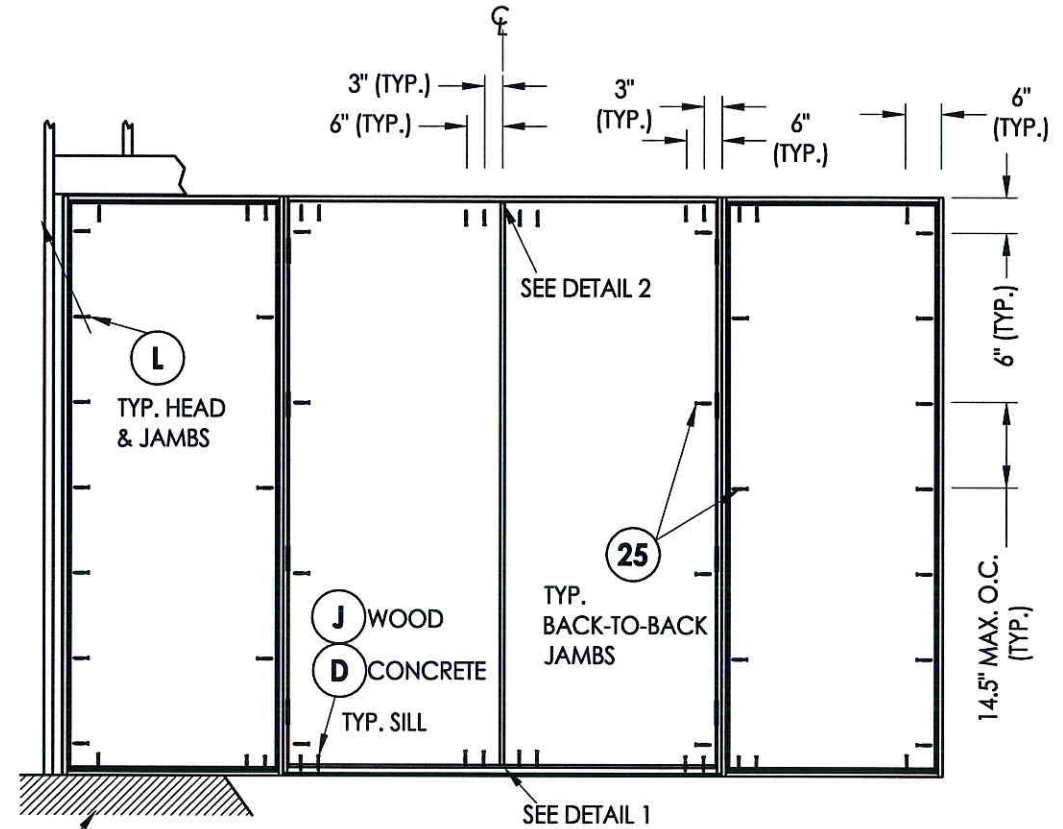

**FRAME ANCHORING
OXXO**

FLOOR SUBSTRATE MATERIAL (TYP.)
CONCRETE (MIN. 3000 PSI)
WOOD (G >= 0.42)

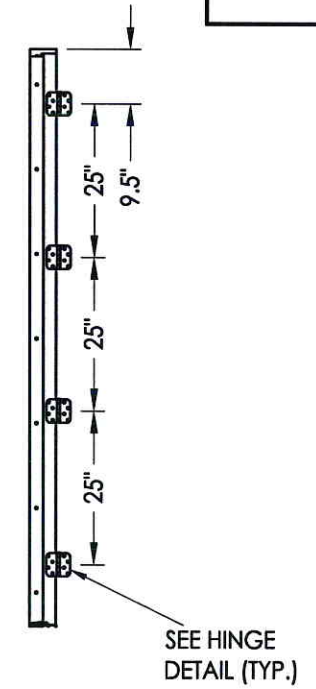

HINGE JAMB

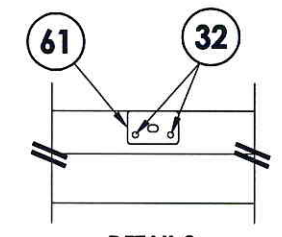

DETAIL 2
Astragal strike plate @ head

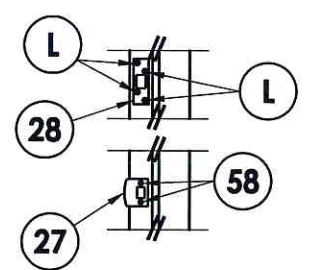

LATCH & DEADBOLT DETAIL
Security Strike

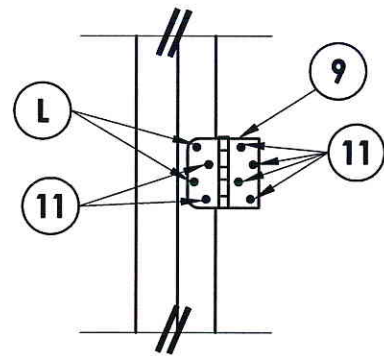

HINGE DETAIL

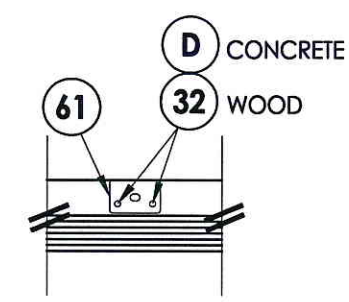

DETAIL 1
Astragal strike plate @ sill
(Outswing)

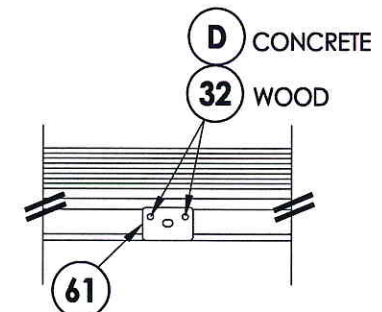

DETAIL 1
Astragal strike plate @ sill
(Inswing)

CONCRETE ANCHOR NOTES:

- Concrete anchor locations at the corners may be adjusted to maintain the min. edge distance to mortar joints.
- Concrete anchor locations noted as "MAX. ON CENTER" must be adjusted to maintain the min. edge distance to mortar joints, additional concrete anchors may be required to ensure the "MAX. ON CENTER" dimension are not exceeded.
- Concrete anchor table:

ANCHOR TYPE	ANCHOR SIZE	MIN. EMBEDMENT	MIN. CLEARANCE TO MASONRY EDGE	MIN. CLEARANCE TO ADJACENT ANCHOR
ITW TAPCON®	1/4"	1-3/4"	2-1/2"	3"
ELCO ULTRAACON®	1/4"	1-3/4"	1"	3"

PRODUCT:	FIBERGLASS DOOR	
PART OR ASSEMBLY:	FRAME ANCHORING	
NO.	DATE	BY
		REVISIONS
DATE:	11/8/12	
SCALE:	N.T.S.	
DWG. BY:	JK	
CHK. BY:	LFS	
DRAWING NO.:	TX-4279	
SHEET	8 of 10	

© 2012 R.W. BUILDING CONSULTANTS INC.

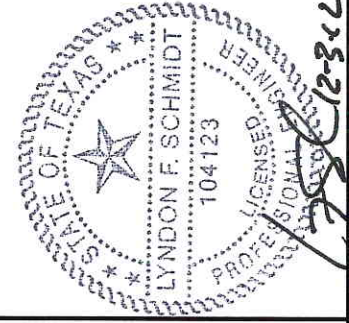
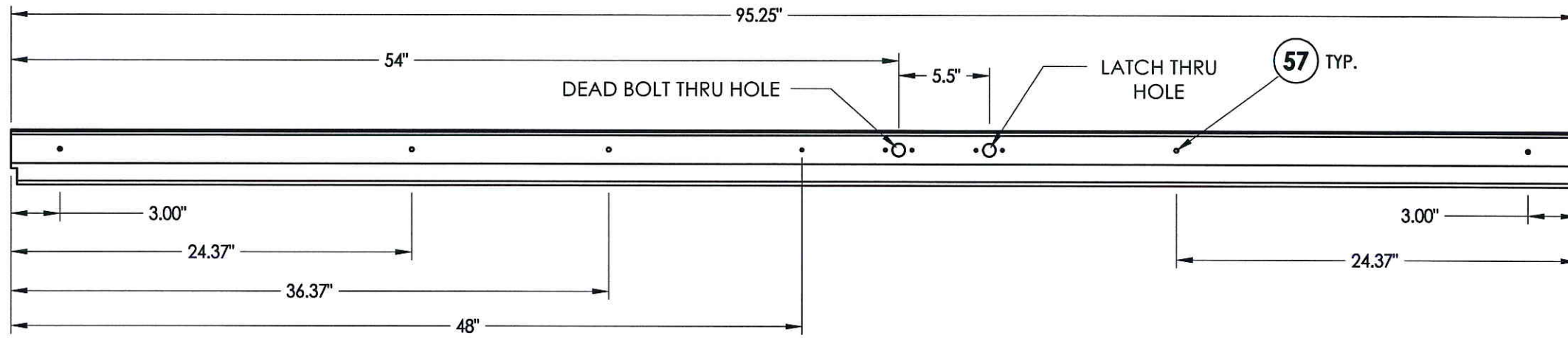

Documents Prepared By: Lyndon F. Schmidt, P.E. TEXAS P.E. #104123

RW BUILDING CONSULTANTS, INC.
P.O. Box 230 Valrico FL 33595
Phone No.: 813.659.9197

TEXAS BOARD OF PROFESSIONAL ENGINEERS
CERTIFICATE OF REGISTRATION # F-11852

TOP

BOTTOM

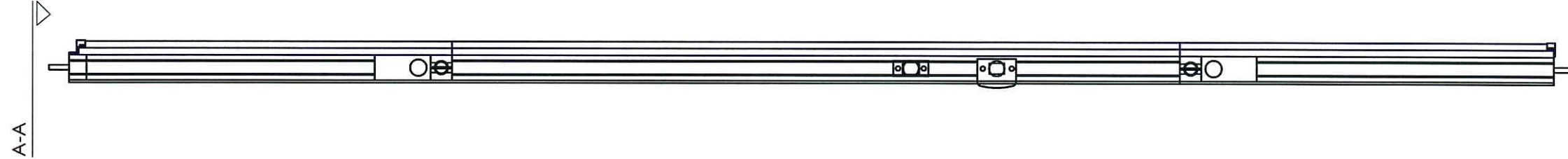

8'0 ALUMINUM ASTRAGAL ASSEMBLY
By Endura Products

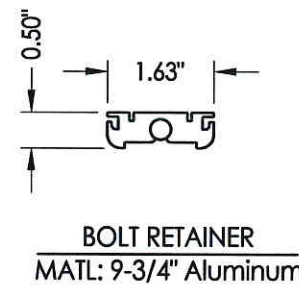
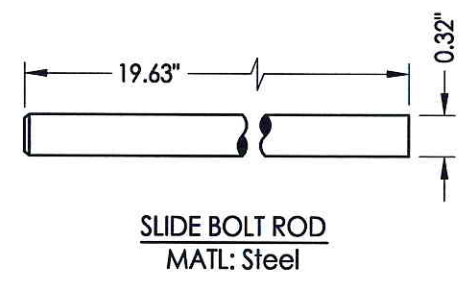
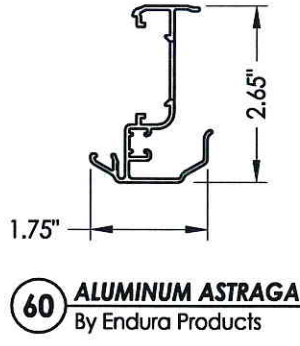
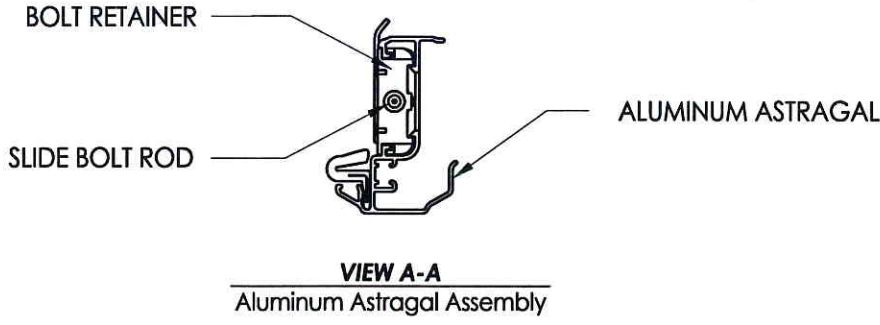

<u>PRODUCT:</u>	FIBERGLASS DOOR
<u>PART OR ASSEMBLY:</u>	ASTRAGAL DETAILS
<u>NO. DATE</u>	<u>BY</u>
	REVISIONS
<u>DATE:</u> 11/8/12	
<u>SCALE:</u> N.T.S.	
<u>DWG. BY:</u> JK	
<u>CHK. BY:</u> LFS	
<u>DRAWING NO.:</u> TX-4279	
<u>SHEET</u> 9 <u>OF</u> 10	

BILL OF MATERIALS

ITEM #	DESCRIPTION	MATERIAL
B	2X FRAMING (G >= 0.42)	WOOD
C	1/4" MAX. SHIM SPACE	-
D	1/4" PFH ITW CONCRETE SCREW (1-3/4" MIN. EMB.)	STEEL
J	#10 X 3" PFH WOOD SCREW (1-1/2" MIN. EMB.)	STEEL
L	#10 X 2-1/2" PFH WOOD SCREW (1.15" MIN. EMB.)	STEEL
1	HEAD & JAMB	COMP
7	WEATHERSTRIP (PE 650 - ENDURA)	FOAM
8	DOOR BOTTOM SWEEP	VINYL
9	4" HINGE	STEEL
11	#9 X 3/4" PFH WOOD SCREW	STEEL
24	#10 X 1-1/2" PFH WOOD SCREW	STEEL
25	#10 X 2" PFH WOOD SCREW	STEEL
27	LATCH STRIKE PLATE	STEEL
28	DEADBOLT STRIKE PLATE	STEEL
30	OUTSWING THRESHOLD	ALUM/COMP
32	#8 X 3" PFH WS	STEEL
36	INSWING THRESHOLD	ALUM/COMP
39	INSWING SIDELITE SEAT	PVC
40	DOOR PANEL - SEE DOOR PANEL DETAIL SHEET FOR DETAILS	-
50	SIDELITE PANEL - SEE SIDELITE PANEL DETAIL SHEET FOR DETAILS	-
57	#8 X 2" PFH SMS	STEEL
58	#8 X 2-1/2" PFH WOOD SCREW	STEEL
60	ASTRAGAL (ENDURA)	ALUM
61	ASTRAGAL STRIKE PLATE	STEEL

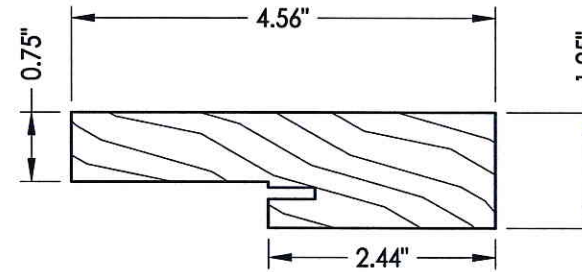

1 HEAD & JAMB
Wood

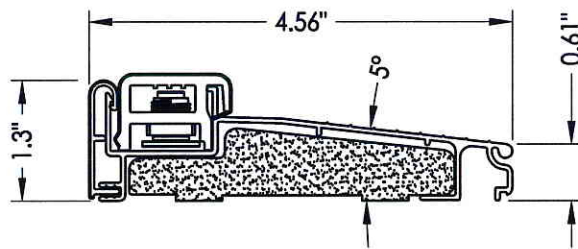

36 INSWING THRESHOLD
ENDURA ZAIL 4565
with Composite Substrate

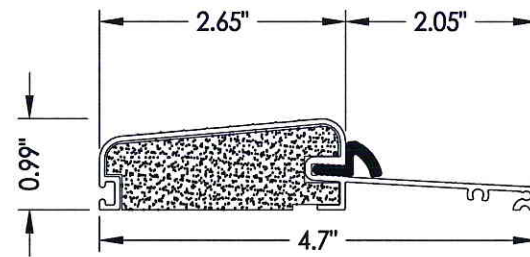

30 OUTSWING THRESHOLD
Columbia 775 Series
w/ Composite Substrate

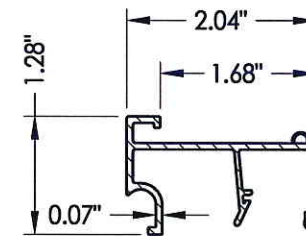

39 INSWING SIDELITE SEAT
ENDURA 60 SERIES

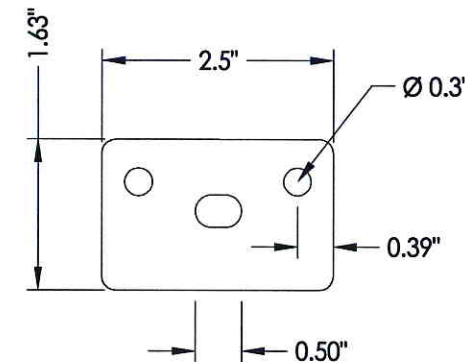

61 ASTRAGAL STRIKE PLATE

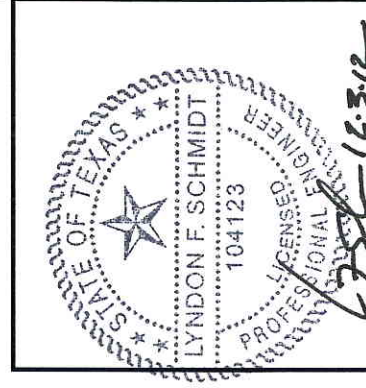

Documents Prepared By: Lyndon F. Schmidt, P.E.
TEXAS P.E. #104123

RW BUILDING CONSULTANTS, INC.
P.O. Box 230 Valrico FL 33595
Phone No.: 813.659.9197
TEXAS BOARD OF PROFESSIONAL ENGINEERS
CERTIFICATE OF REGISTRATION # F-11852

PRODUCT: FIBERGLASS DOOR
PART OR ASSEMBLY: BILL OF MATERIALS & COMPONENTS

NO.	DATE	BY	REVISIONS

DATE: 11/8/12
SCALE: N.T.S.
DWG. BY: JK
CHK. BY: LFS
DRAWING NO.: TX-4279
SHEET 10 of 10