

"Smooth Star", "Fiber Classic" & "Classic Craft"

Opaque Fiberglass Single Door w/ or w/o Sidelites

INSWING / OUTSWING
"Non-Impact"



Documents Prepared By: Lyndon F. Schmidt, P.E.
TEXAS P.E. #104123

RW BUILDING CONSULTANTS, INC.
P.O. Box 230 Vairico FL 33595
Phone No.: 813.659.9197

TEXAS BOARD OF PROFESSIONAL ENGINEERS
CERTIFICATE OF REGISTRATION # F-11852

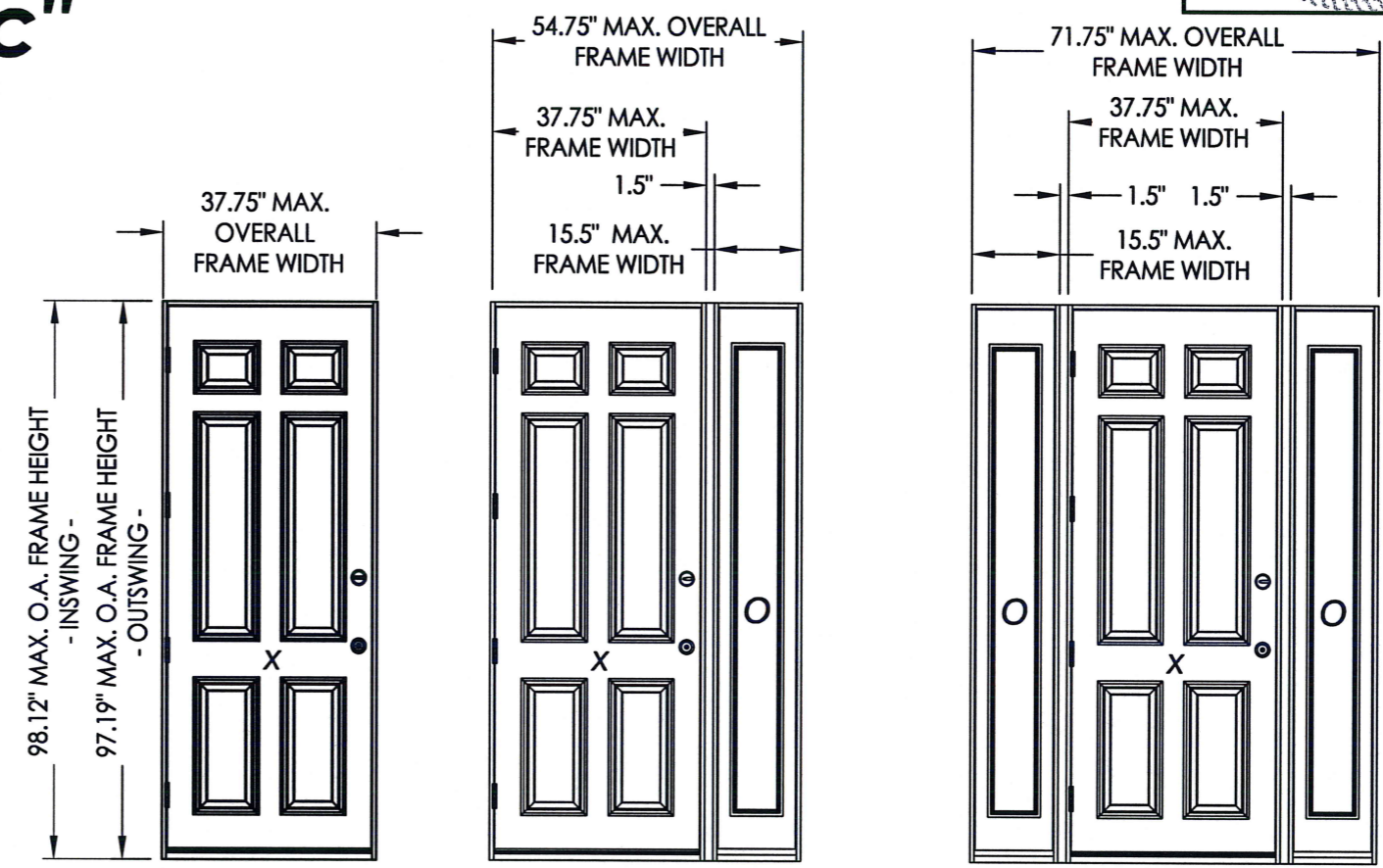

EVALUATED FOR USE IN THE STATE OF TEXAS

The Thermo-Tru FIBERGLASS door described herein complies with the 2006 International Residential Code (IRC), Sections R301 & R613 and the 2006 International Building Code (IBC), Sections 1405.12, 1609, 1714.5, 2403 and 2404 (including Texas revisions) subject to the following conditions:

1. Anchors shall be as listed and spaced as shown in the details. Anchor embedment to base material shall be beyond wall dressing or stucco.
2. When used in areas requiring wind-borne debris protection, this product is required to be protected with an impact resistant covering that complies with Section R301.2.1.2 of the IRC and Section 1609.1.2 of the IBC.
3. Allowable design pressure requirements must be equal to or less than the design pressure rating shown in the design pressure chart, sheet 1 of this drawing.
4. Conditions not covered by this drawing are subject to further engineering analysis.

TABLE OF CONTENTS

SHEET #	DESCRIPTION
1	Typical elevations, design pressures & general notes
2	Door panel details (Smooth Star/Fiber Classic)
3	Door panel details (Classic Craft)
4	Sidelite panel & glazing detail (Smooth Star/Fiber Classic)
5	Sidelite panel & glazing detail (Classic Craft)
6	Elevations
7	Horizontal cross sections
8	Vertical cross sections
9	Vertical cross sections
10	Frame anchoring
11	Bill of materials and components

CONFIGURATION	MAX. FRAME DIMENSION	SWING	DESIGN PRESSURE (PSF) SMOOTH STAR / FIBER CLASSIC		DESIGN PRESSURE (PSF) CLASSIC CRAFT	
			POSITIVE	NEGATIVE	POSITIVE	NEGATIVE
X	37.75" x 98.12"	INSWING	+80.0	-85.0	+80.0	-85.0
	37.75" x 97.19"	OUTSWING	+80.0	-80.0	+80.0	-80.0
OX or XO	54.75" x 98.12"	INSWING	+55.0	-65.0	+55.0	-65.0
	54.75" x 97.19"	OUTSWING	+55.0	-55.0	+55.0	-55.0
OXO	71.75" x 98.12"	INSWING	+55.0	-65.0	+55.0	-65.0
	71.75" x 97.19"	OUTSWING	+55.0	-55.0	+55.0	-55.0

PRODUCT: THERMA-TRU FIBERGLASS DOOR

PART OR ASSEMBLY: TYPICAL ELEVATION, DESIGN PRESSURES & GENERAL NOTES

NO.	DATE	BY	REVISIONS

DATE: 10/08/12

SCALE: N.T.S.

DWG. BY: JK

CHK. BY: LFS

DRAWING NO.: TX-4260

SHEET 1 OF 11

R:\A - Projects\Project Folders\Proj 1601 - 1700\PF 1694\DWG\RWBC Drawings\Texas 2012\TX-4260-61.dwg, 2

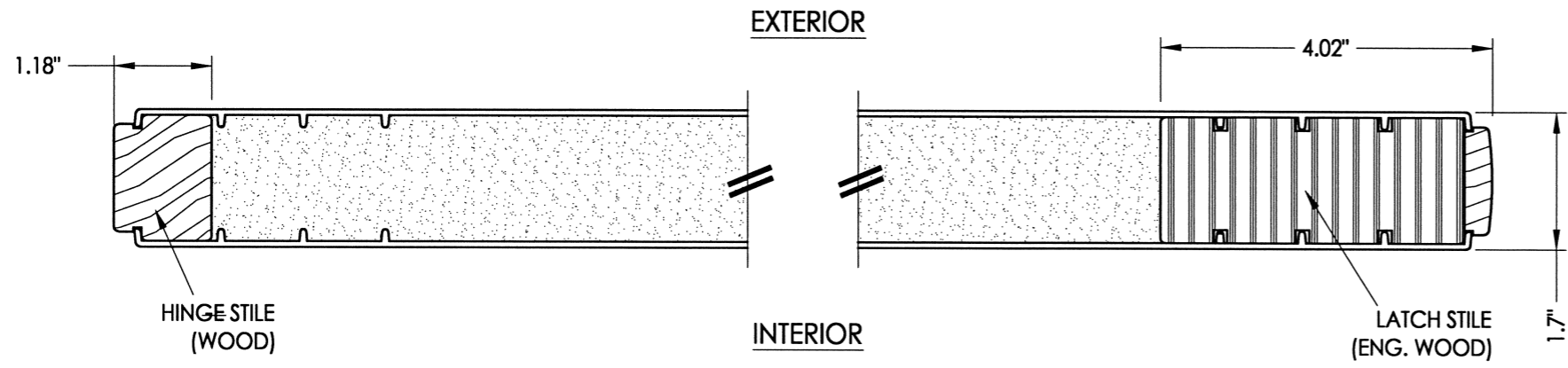

1
2 HORIZONTAL CROSS SECTION

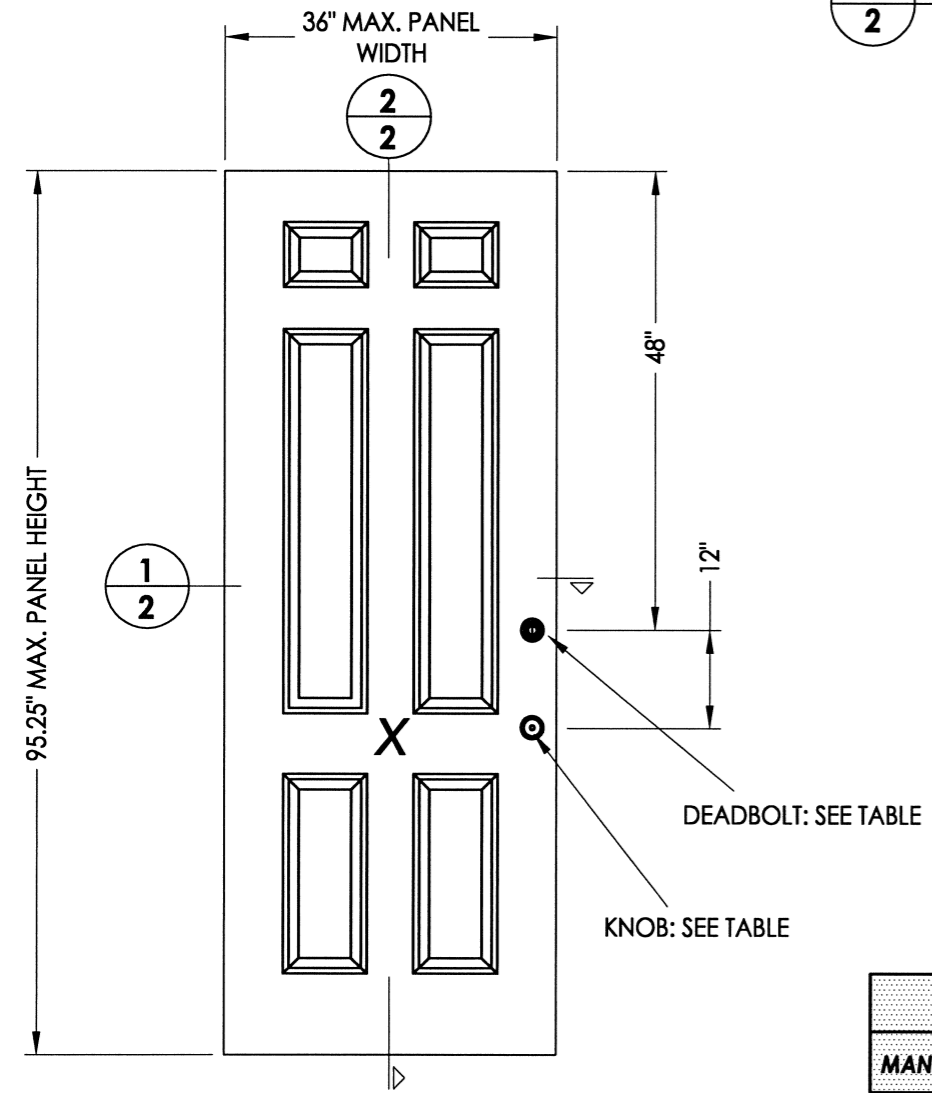

40 DOOR PANEL
Smooth Star/Fiber Classic

HARDWARE TABLE		
MANUFACTURER	MODEL	MAX. DESIGN PRESSURE
Kwikset	Knob: SIGNATURE SERIES	80 PSF
	Deadbolt: SIGNATURE SERIES (980)	
Schlage	Knob: "F" SERIES	85 PSF
	Deadbolt: "B" SERIES	

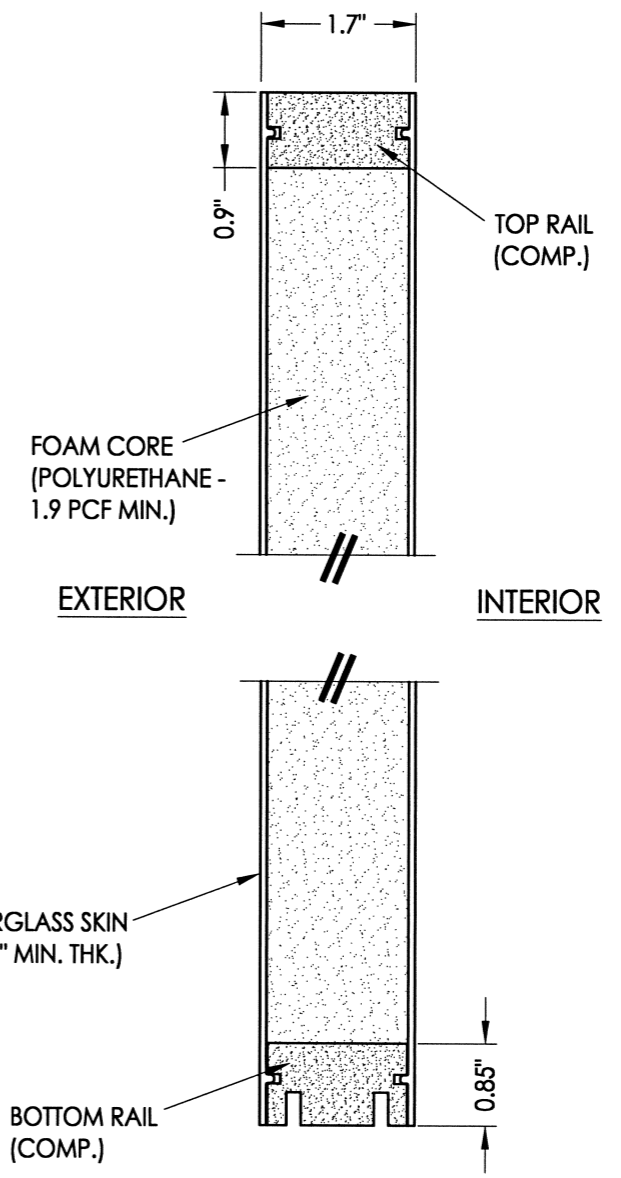

2
2 VERTICAL CROSS SECTION

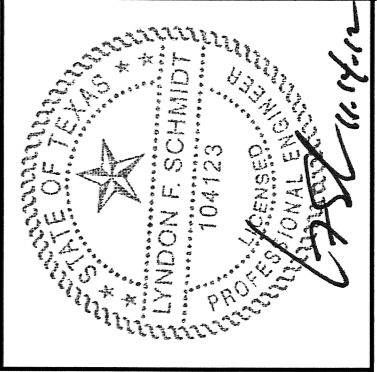

Documents Prepared By: Lyndon F. Schmidt, P.E.
TEXAS P.E. #104123

RW BUILDING CONSULTANTS, INC.
P.O. Box 230 Valrico FL 33595
Phone No.: 813.659.9197

TEXAS BOARD OF PROFESSIONAL ENGINEERS
CERTIFICATE OF REGISTRATION # F-11852

PRODUCT: THERMA-TRU
FIBERGLASS DOOR

PART OR ASSEMBLY:
DOOR PANEL DETAILS

NO.	DATE	BY	REVISIONS

DATE: 10/08/12
SCALE: N.T.S.
DWG. BY: JK
CHK. BY: LFS
DRAWING NO.: TX-4260
SHEET 2 OF 11

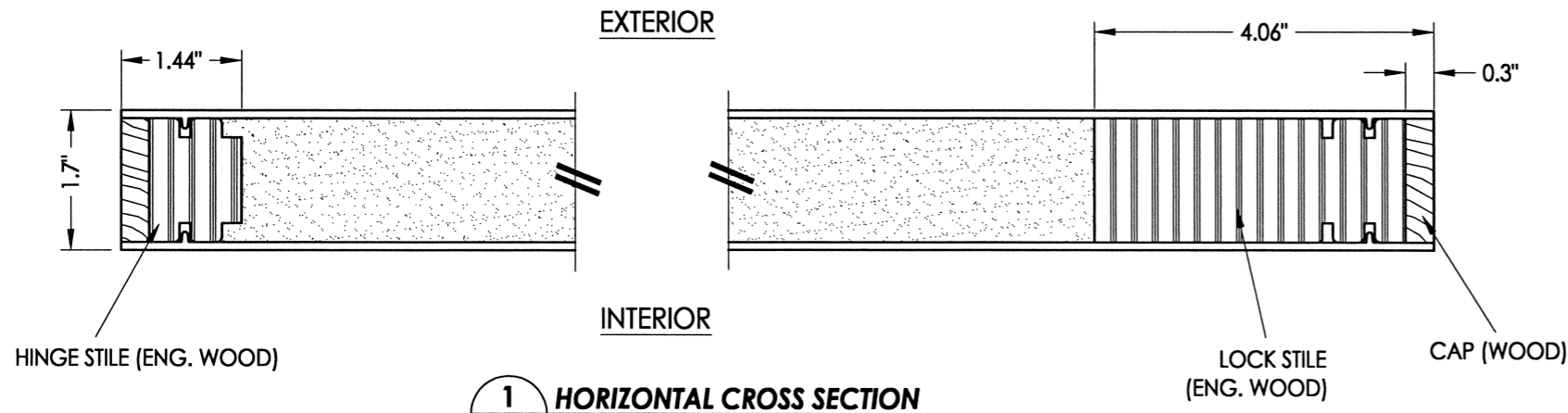

1
3 **HORIZONTAL CROSS SECTION**

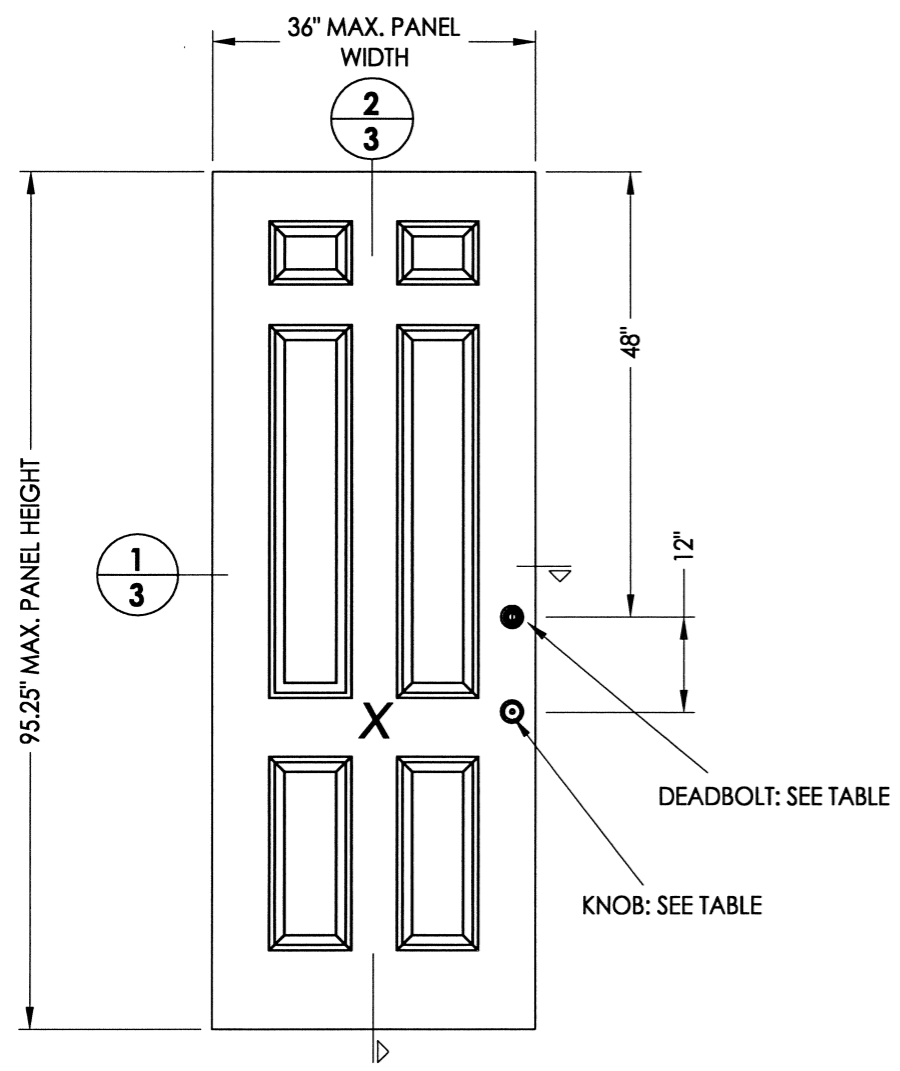

41 **DOOR PANEL**
Classic Craft

HARDWARE TABLE		
MANUFACTURER	MODEL	MAX. DESIGN PRESSURE
KWIKSET	Knob: SIGNATURE SERIES	80 PSF
	DEADBOLT: SIGNATURE SERIES (980)	
SCHLAGE	Knob: "F" SERIES	85 PSF
	DEADBOLT: "B" SERIES	

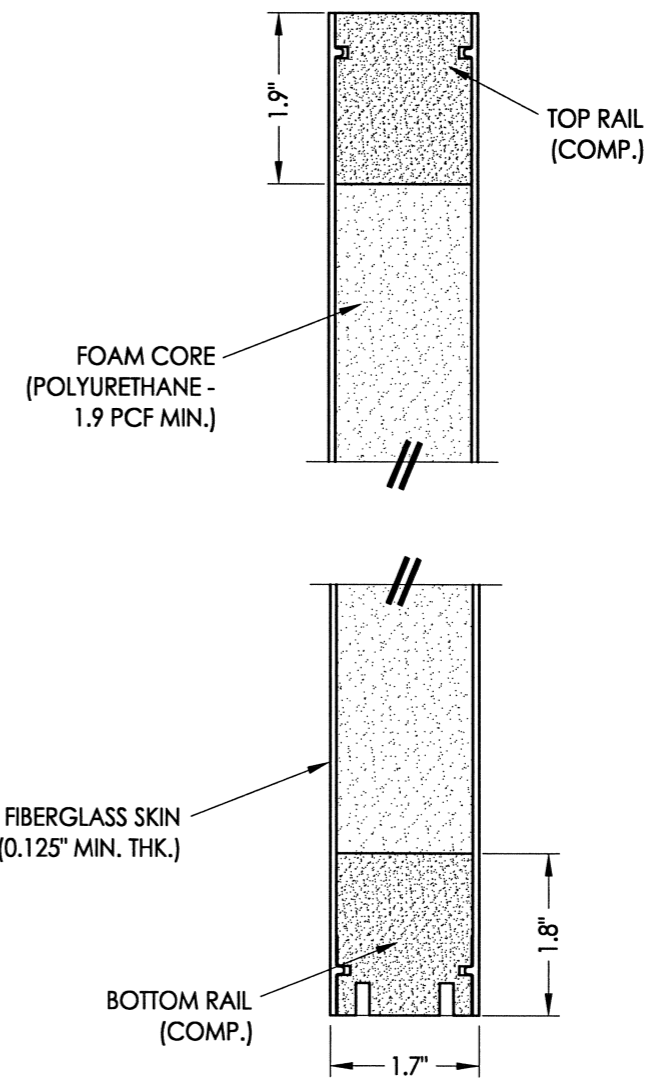

2
3 **VERTICAL CROSS SECTION**

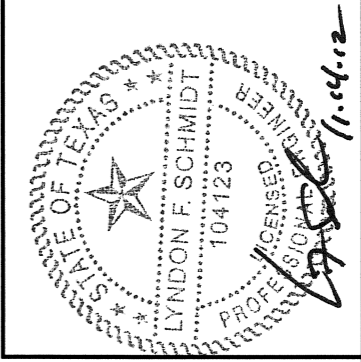

Documents Prepared By: Lyndon F. Schmidt, P.E.
TEXAS P.E. #104123

RW BUILDING CONSULTANTS, INC.
P.O. Box 230 Valrico FL 33595
Phone No.: 813.659.9197

TEXAS BOARD OF PROFESSIONAL ENGINEERS
CERTIFICATE OF REGISTRATION # F-11852

PRODUCT: THERMA-TRU
FIBERGLASS DOOR

PART OR ASSEMBLY:
DOOR PANEL DETAILS

REVISIONS	
NO.	DATE

DATE: 10/08/12
SCALE: N.T.S.
DWG. BY: JK
CHK. BY: LFS
DRAWING NO.: TX-4260
SHEET 3 OF 11

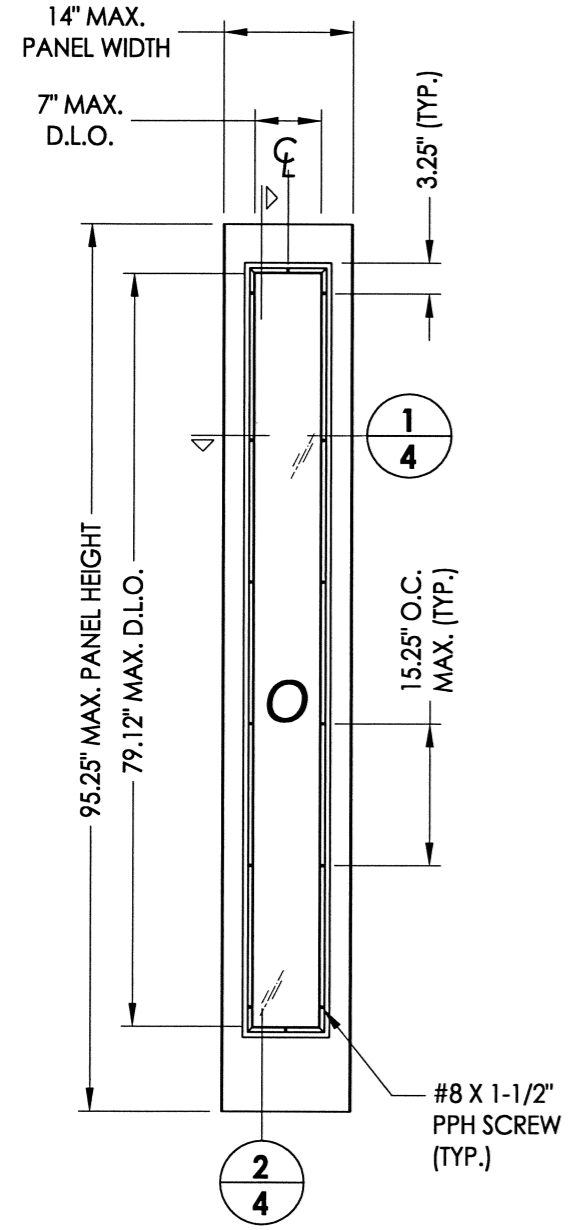
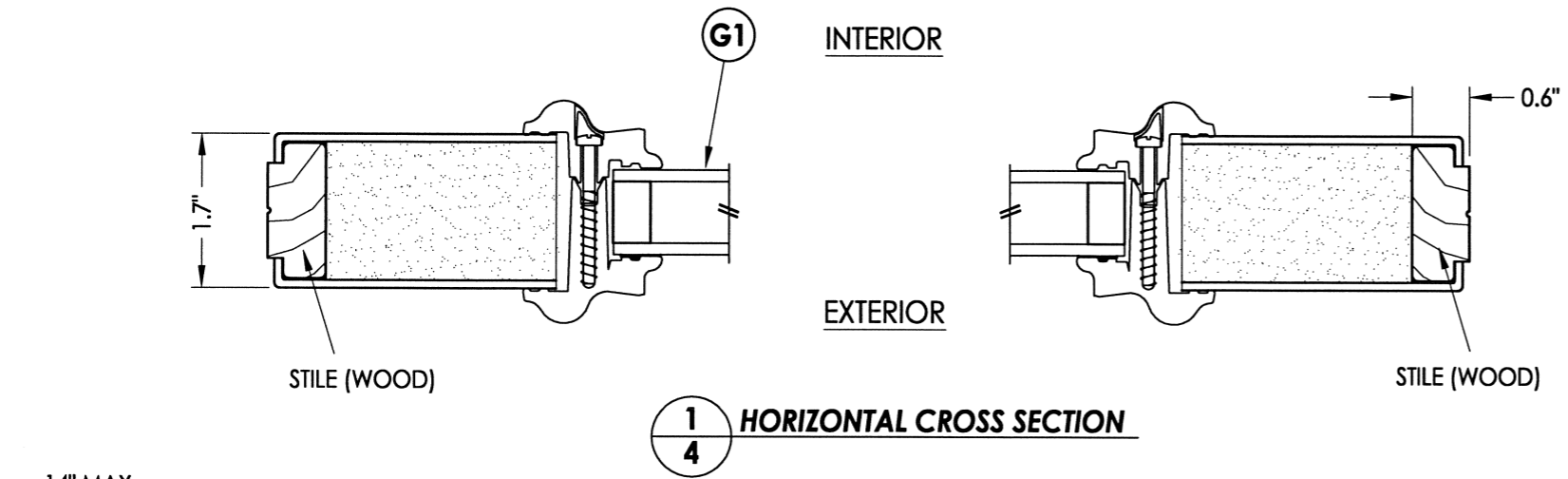

50 **SIDELITE PANEL**
Smooth Star/Fiber Classic

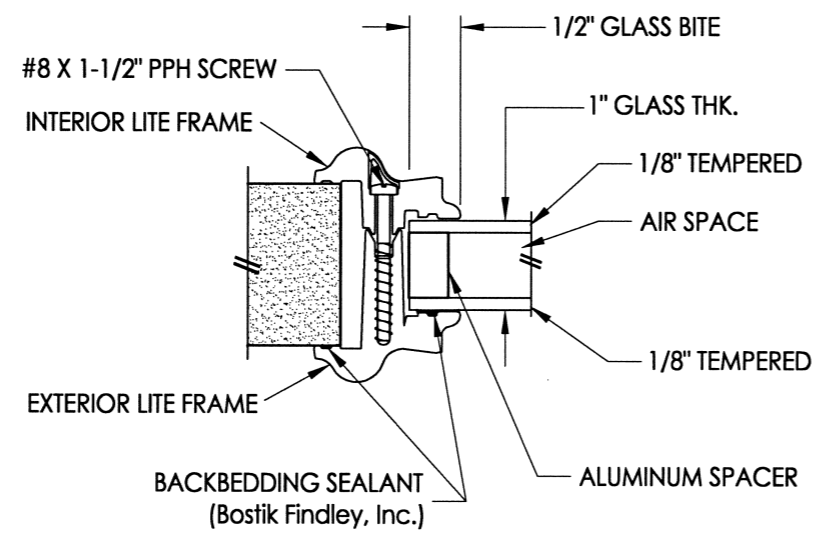

G1 **GLAZING DETAIL**
BTS Lip Lite Frame

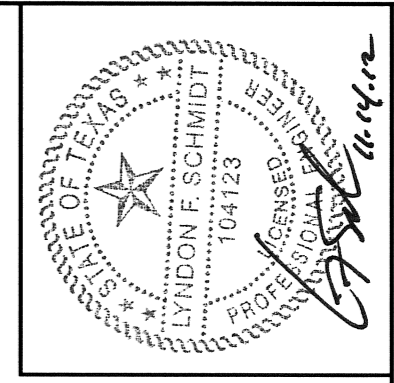
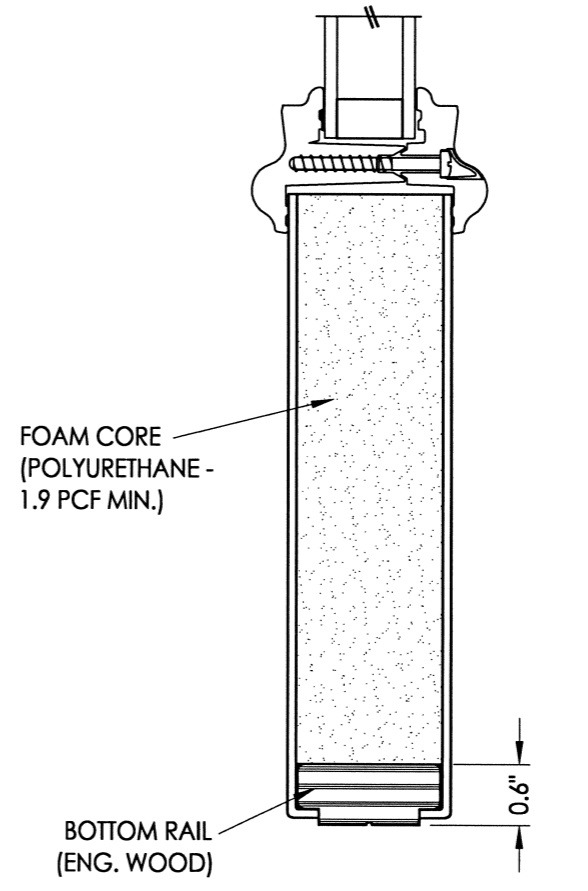
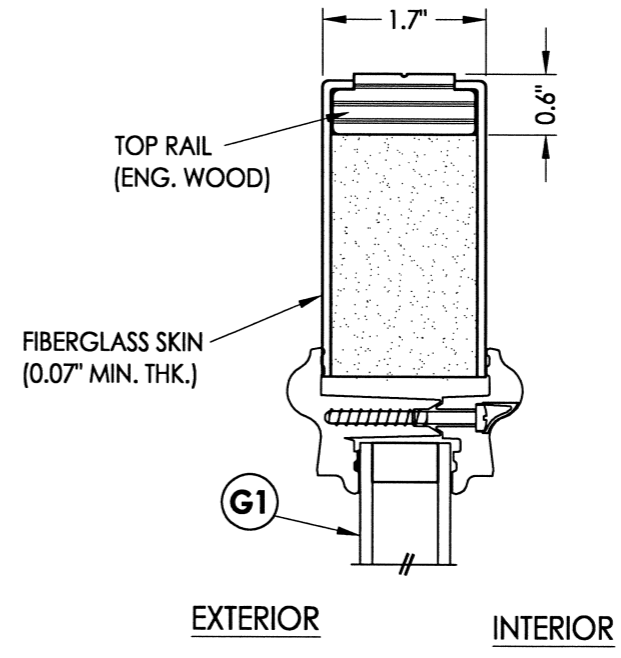
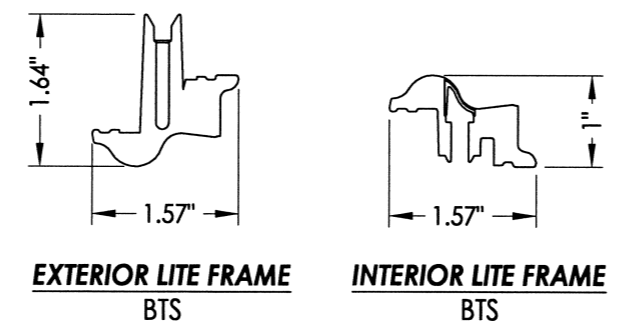

Documents Prepared By: Lyndon F. Schmidt, P.E.
TEXAS P.E. #104123

RW BUILDING CONSULTANTS, INC.
P.O. Box 230 Valrico FL 33595
Phone No.: 813.659.9197

TEXAS BOARD OF PROFESSIONAL ENGINEERS
CERTIFICATE OF REGISTRATION # F-11852

PRODUCT: THERMA-TRU
FIBERGLASS DOOR

PART OR ASSEMBLY:
SIDELITE PANEL & GLAZING DETAIL
(SMOOTH STAR/FIBER CLASSIC)

NO.	DATE	BY	REVISIONS

DATE: 10/08/12
SCALE: N.T.S.
DWG. BY: JK
CHK. BY: LFS
DRAWING NO.: TX-4260
SHEET 4 OF 11

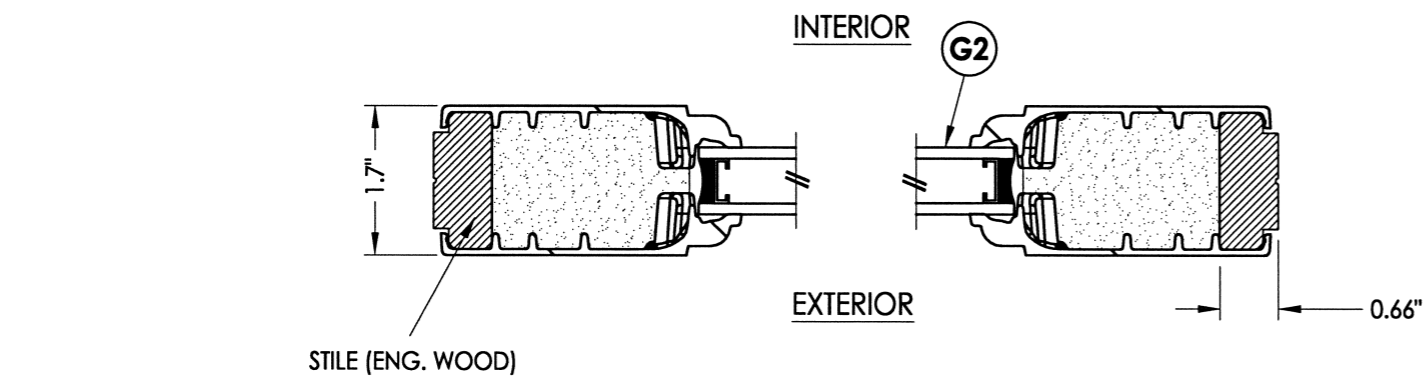

1
5 HORIZONTAL CROSS SECTION

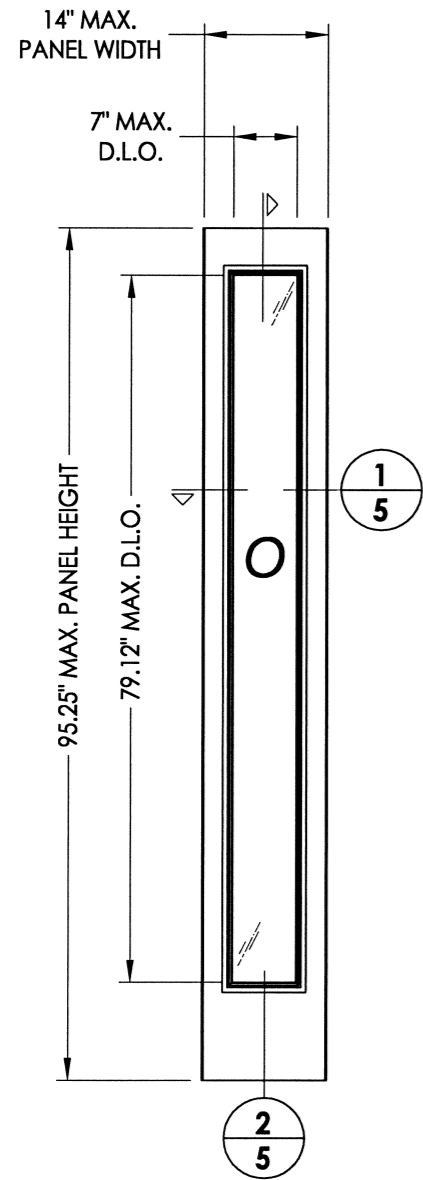

51 SIDELITE PANEL
Classic Craft

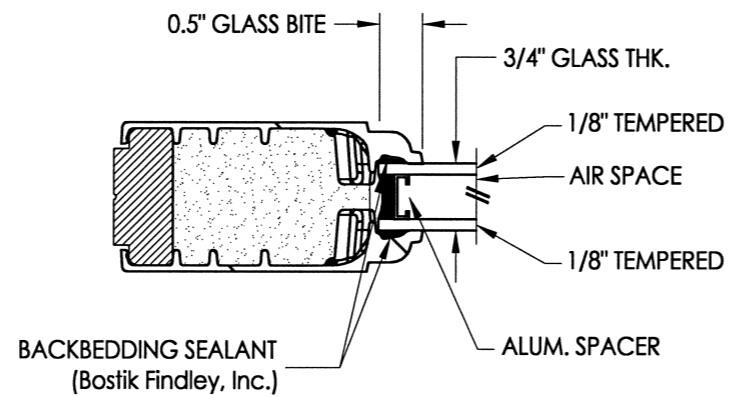

G2 GLAZING DETAIL
Flush Glazed

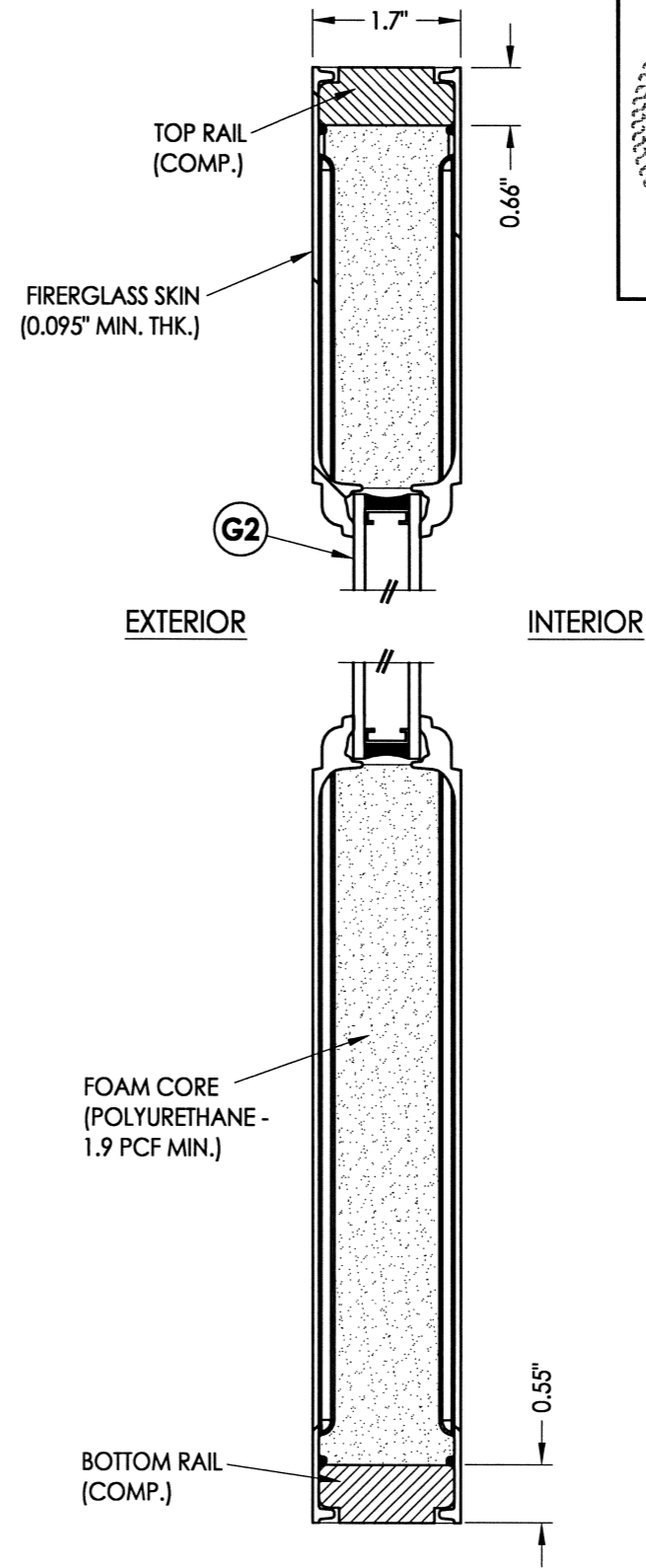

2
5 VERTICAL CROSS SECTION

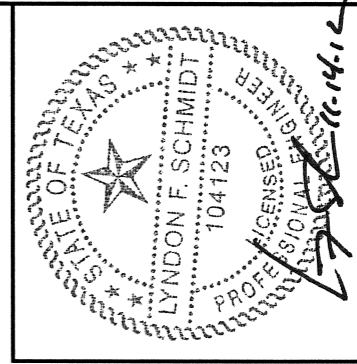

Documents Prepared By: Lyndon F. Schmidt, P.E.
TEXAS P.E. #104123

RW BUILDING CONSULTANTS, INC.
P.O. Box 230 Valrico FL 33595
Phone No.: 813.659.9197

TEXAS BOARD OF PROFESSIONAL ENGINEERS
CERTIFICATE OF REGISTRATION # F-11852

PRODUCT: THERMA-TRU
FIBERGLASS DOOR
PART OR ASSEMBLY:
SIDELITE PANEL & GLAZING DETAIL
(CLASSIC CRAFT)

NO.	DATE	BY	REVISIONS

DATE: 10/08/12
SCALE: N.T.S.
DWG. BY: JK
CHK. BY: LFS
DRAWING NO.: TX-4260
SHEET 5 OF 11

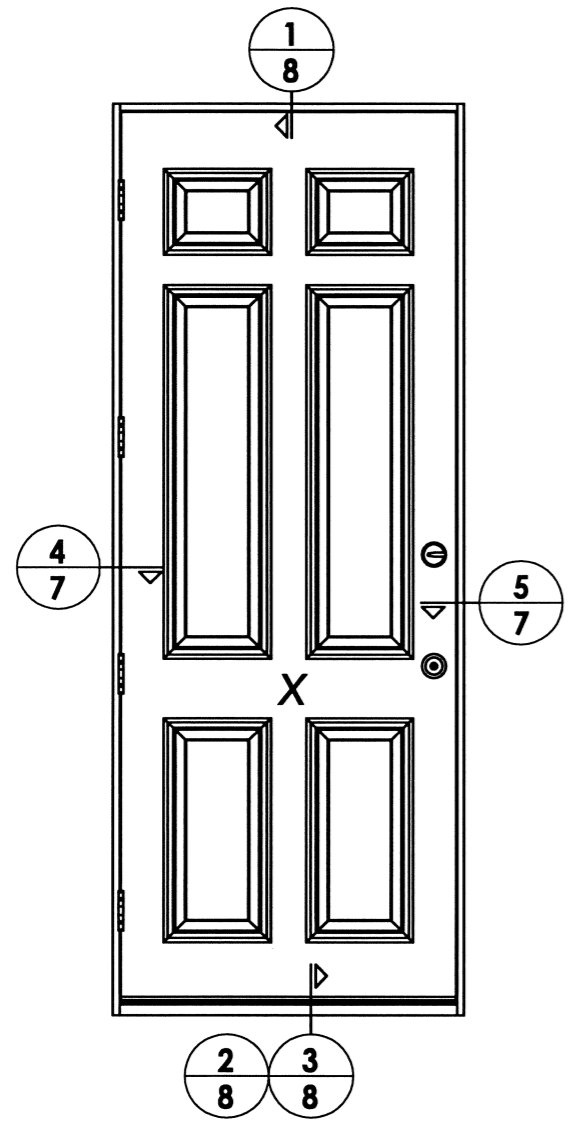

ELEVATION (X)

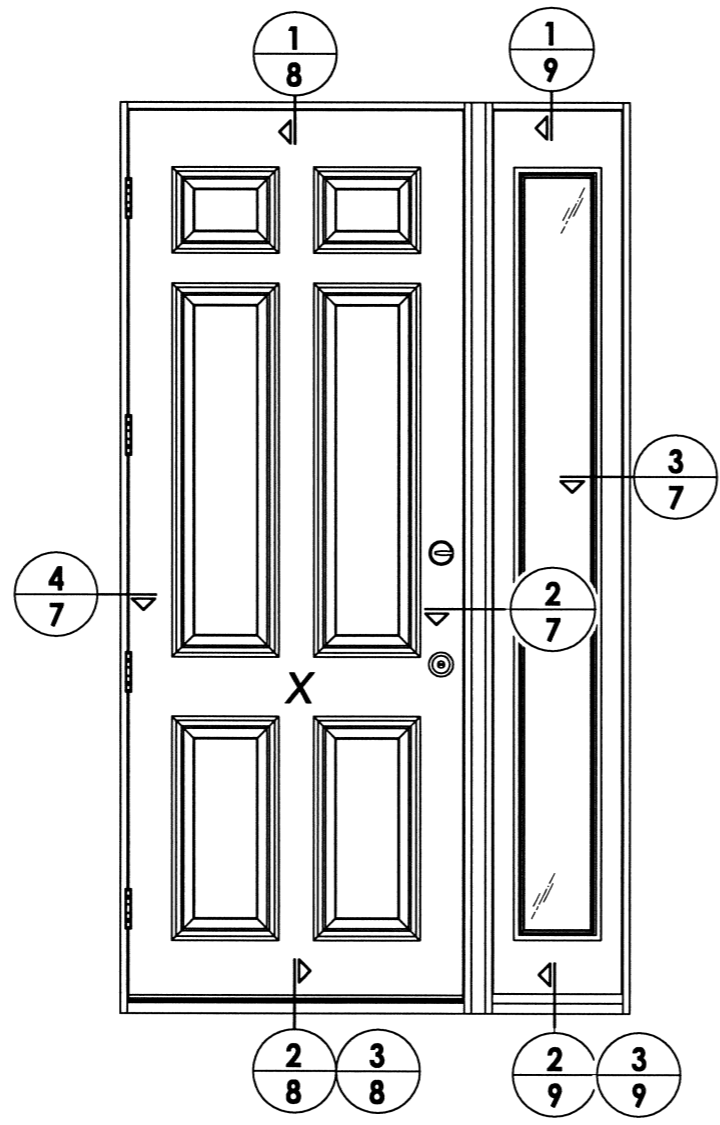

ELEVATION (OX / XO)

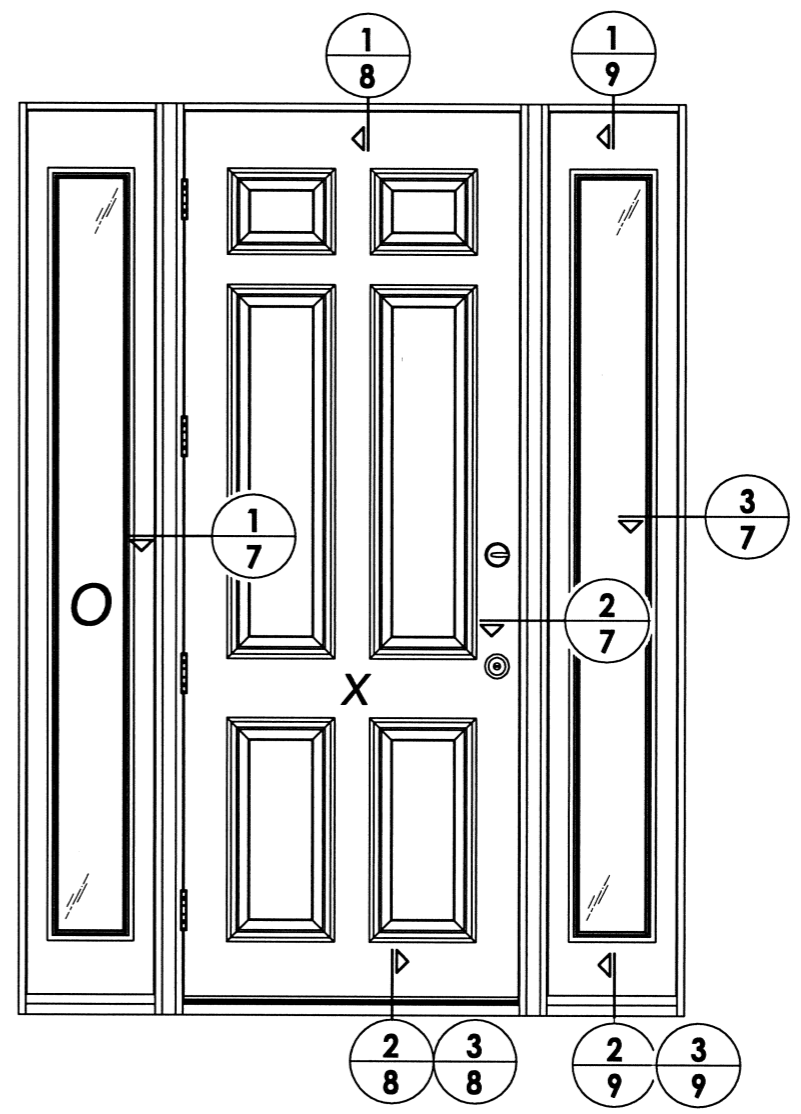

ELEVATION (OXO)

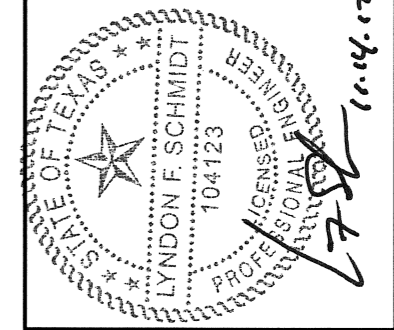

Documents Prepared By: Lyndon F. Schmidt, P.E.
TEXAS P.E. #104123

RW BUILDING CONSULTANTS, INC.
P.O. Box 230 Valrico FL 33595
Phone No.: 813.659.9197
TEXAS BOARD OF PROFESSIONAL ENGINEERS
CERTIFICATE OF REGISTRATION # F-11852

PRODUCT: THERMA-TRU
FIBERGLASS DOOR
PART OR ASSEMBLY:
ELEVATIONS

NO.	DATE	BY	REVISIONS

DATE: 10/08/12
SCALE: N.T.S.
DWG. BY: JK
CHK. BY: LFS
DRAWING NO.: TX-4260
SHEET 6 OF 11

R:\A - Projects\Project Folders\Proj 1601 - 1700\PF 1694\D. RWBC Drawings\Texas 2012\TX-4260-61.dwg, 7

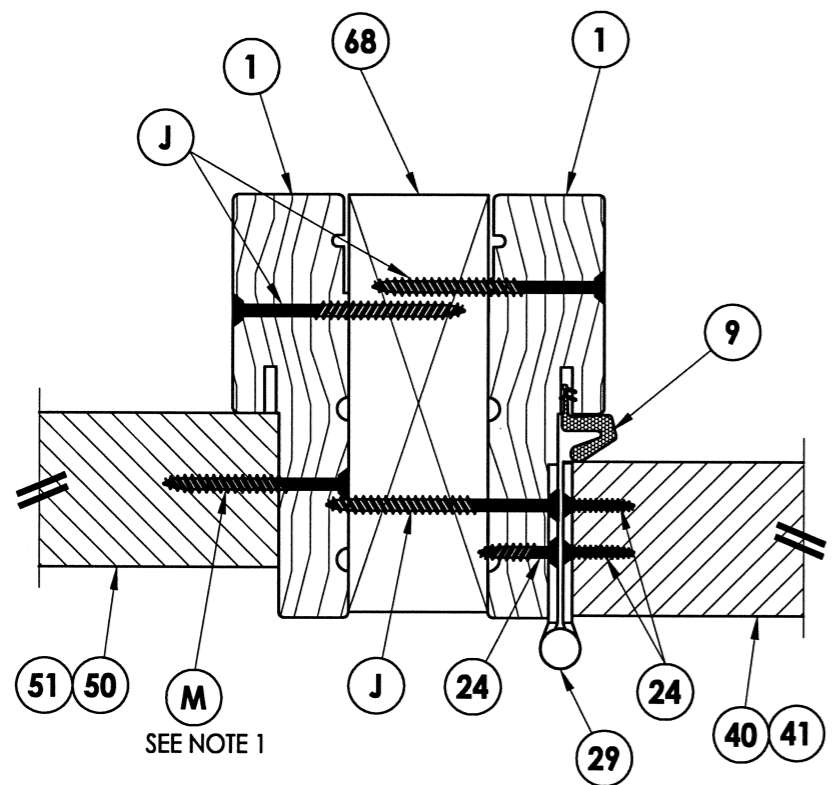

1 HORIZONTAL CROSS SECTION
7 Inswing shown - Outswing also approved

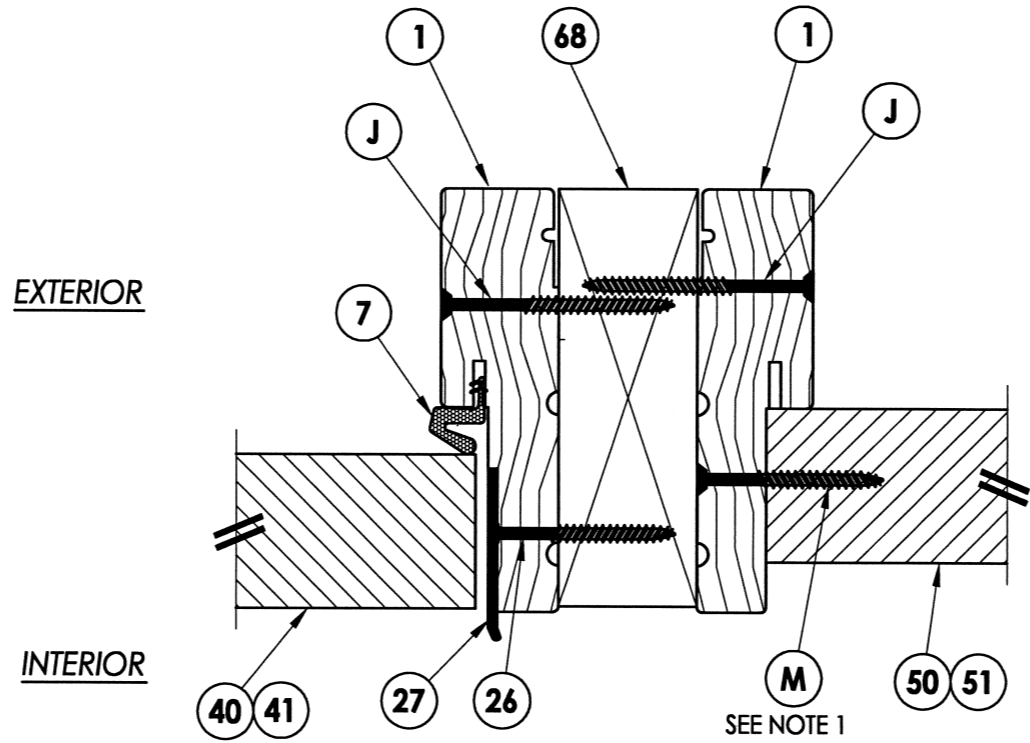

2 HORIZONTAL CROSS SECTION
7 Inswing shown - Outswing also approved

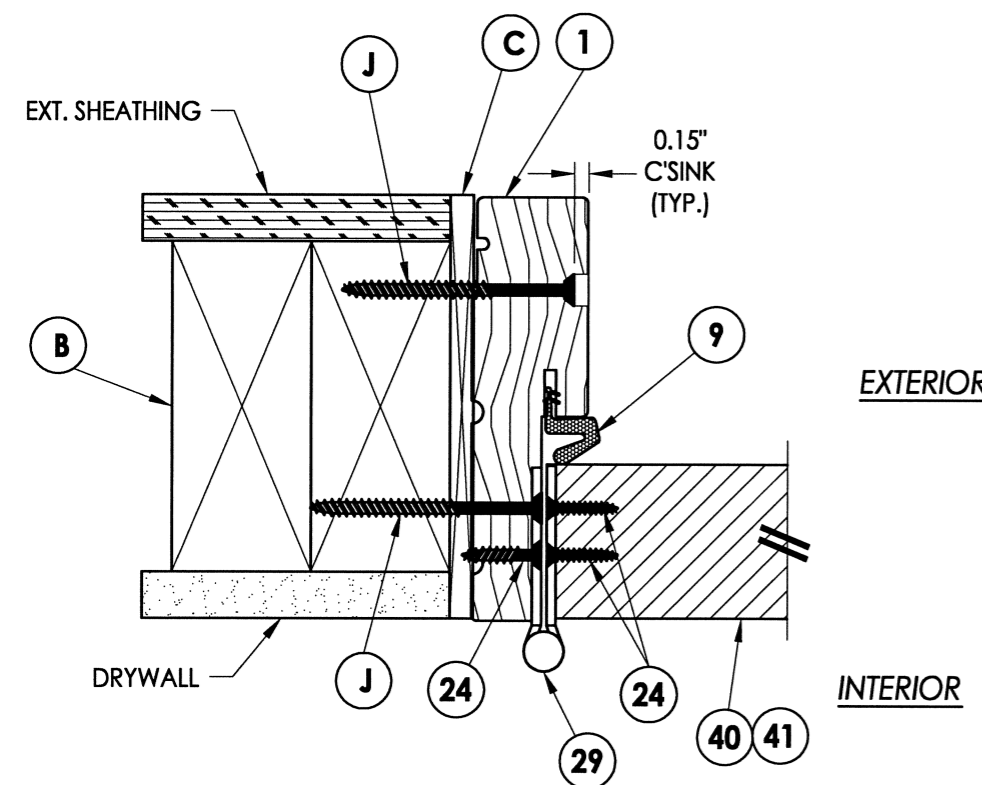

4 HORIZONTAL CROSS SECTION
7 Inswing shown - Outswing also approved

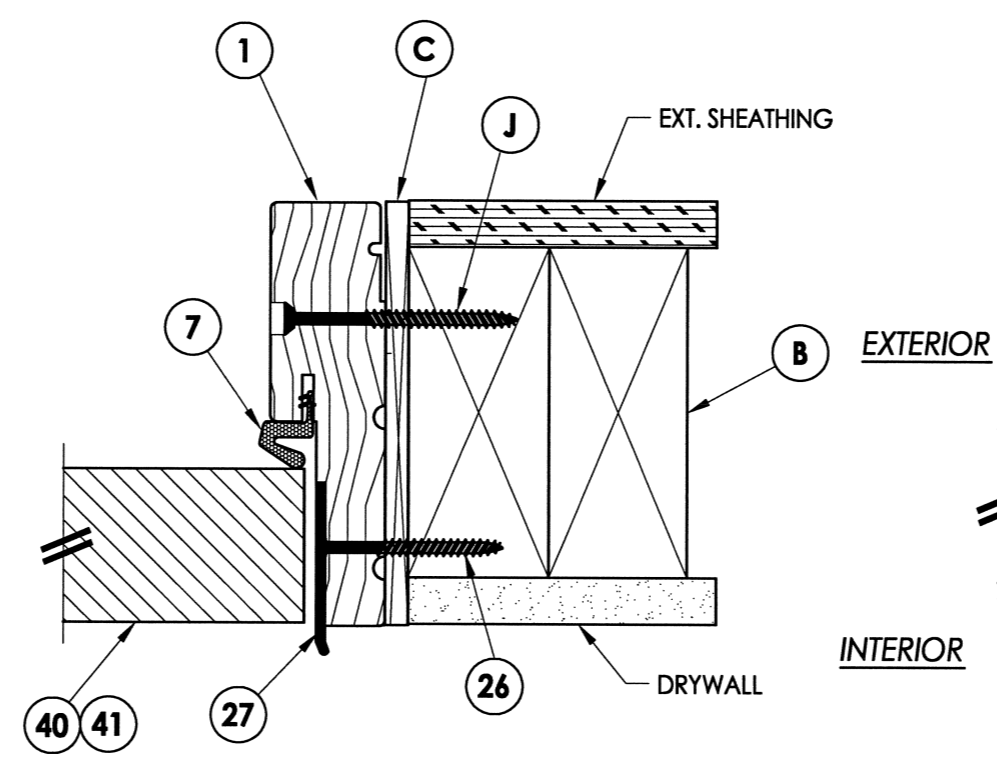

5 HORIZONTAL CROSS SECTION
7 Inswing shown - Outswing also approved

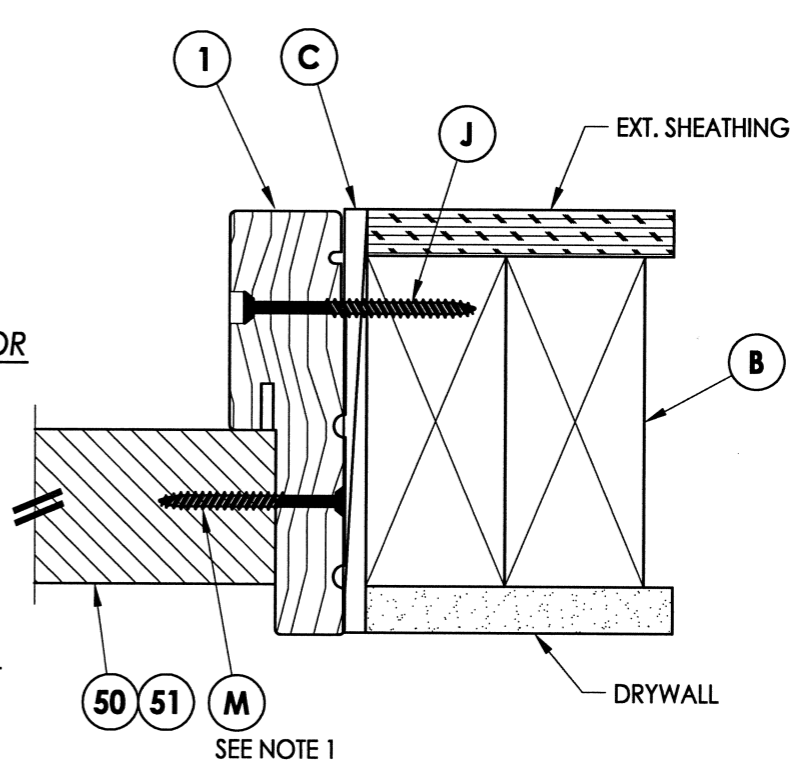

3 HORIZONTAL CROSS SECTION
7 Inswing shown - Outswing also approved

Note:
 1. Sidelite assembly screws located 11-1/2" from each end plus 1 more at the center of jamb (3 total).

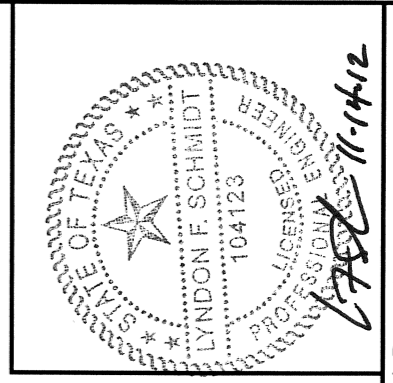

Documents Prepared By: Lyndon F. Schmidt, P.E.
 TEXAS P.E. #104123

RW BUILDING CONSULTANTS, INC.
 P.O. Box 230 Valrico FL 33595
 Phone No.: 813.659.9197
 TEXAS BOARD OF PROFESSIONAL ENGINEERS
 CERTIFICATE OF REGISTRATION # F-11852

PRODUCT:	THERMA-TRU FIBERGLASS DOOR
PART OR ASSEMBLY:	HORIZONTAL CROSS SECTIONS

NO.	DATE	BY	REVISIONS

DATE:	10/08/12
SCALE:	N.T.S.
DWG. BY:	JK
CHK. BY:	LFS
DRAWING NO.:	TX-4260
SHEET	7 OF 11

R:\A - Projects\Project Folders\Proj 1601 - 1700\PF 1694\D. RWBC Drawings\Texas 2012\TX-4260-61.dwg, 8

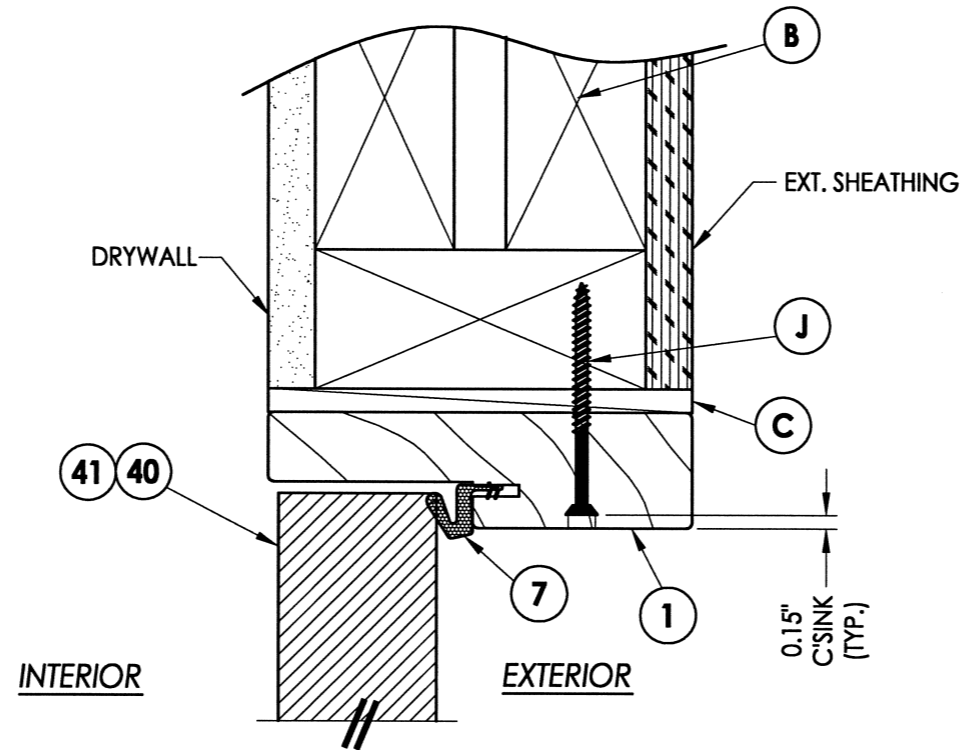

1 VERTICAL CROSS SECTION
8 Inswing shown - Outswing also approved

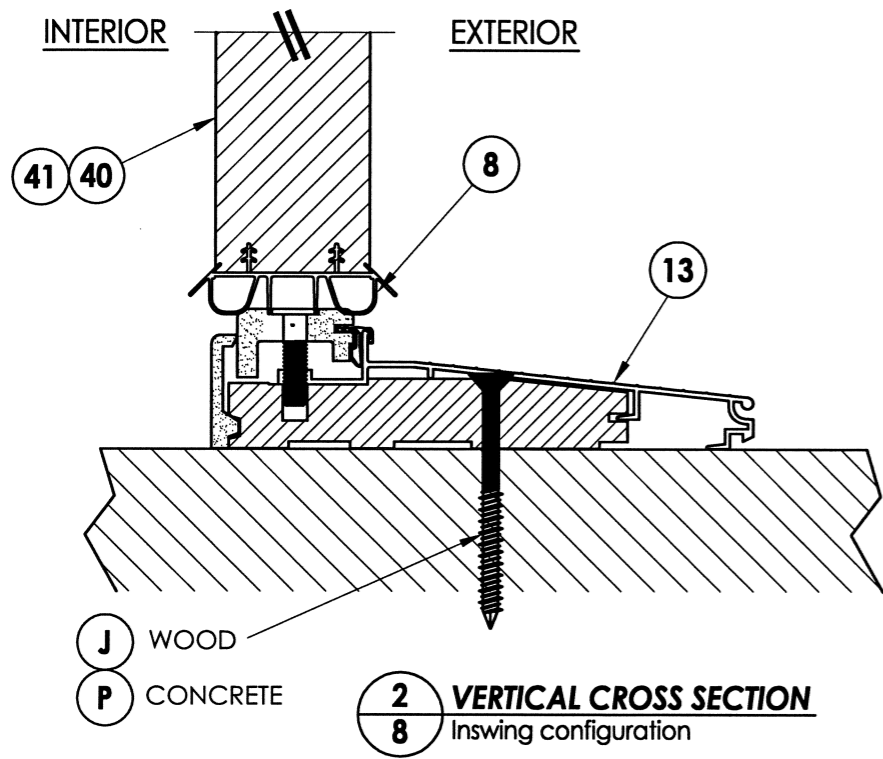

2 VERTICAL CROSS SECTION
8 Inswing configuration

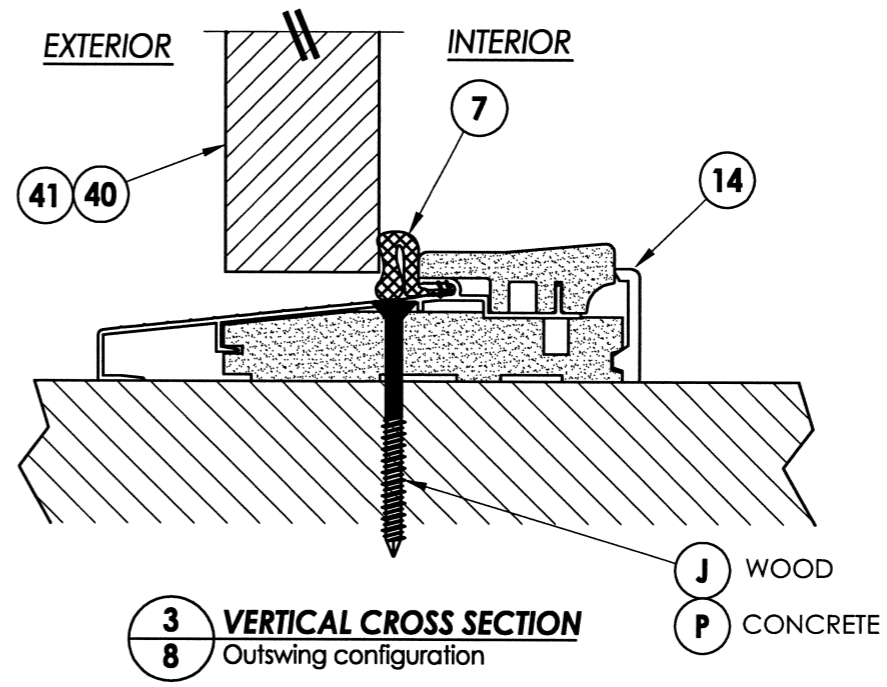

3 VERTICAL CROSS SECTION
8 Outswing configuration

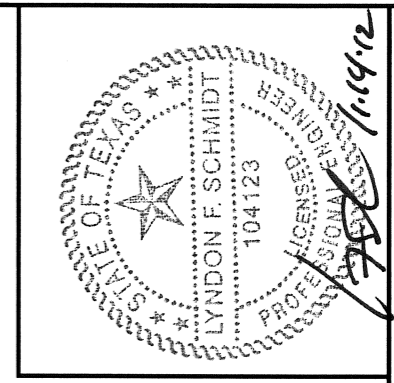

Documents Prepared By: Lyndon F. Schmidt, P.E.
 TEXAS P.E. #104123

RW BUILDING CONSULTANTS, INC.
 P.O. Box 230 Valrico FL 33595
 Phone No.: 813.659.9197
 TEXAS BOARD OF PROFESSIONAL ENGINEERS
 CERTIFICATE OF REGISTRATION # F-11852

PRODUCT: THERMA-TRU FIBERGLASS DOOR
 PART OR ASSEMBLY: VERTICAL CROSS SECTIONS

NO.	DATE	BY

DATE: 10/08/12
 SCALE: N.T.S.
 DWG. BY: JK
 CHK. BY: LFS
 DRAWING NO.: TX-4260
 SHEET 8 OF 11

© 2012 R.W. BUILDING CONSULTANTS INC.

R:\A - Projects\Project Folders\Proj_1601 - 1700\PF_1694\D. RWBC Drawings\Texas 2012\TX-4260-61.dwg, 9

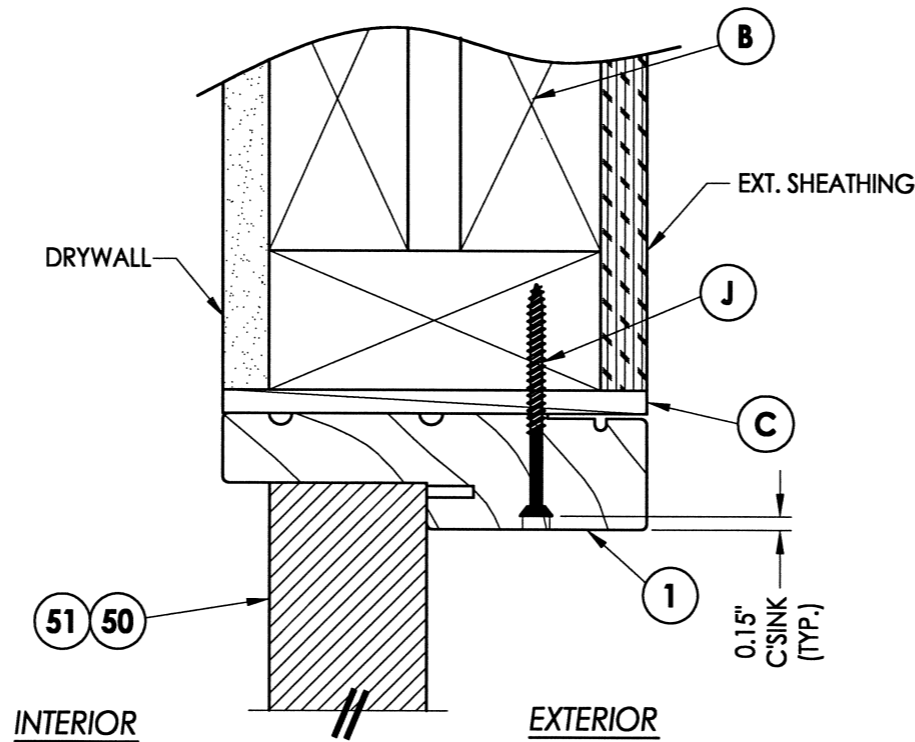

1 VERTICAL CROSS SECTION
9 Inswing shown - Outswing also approved

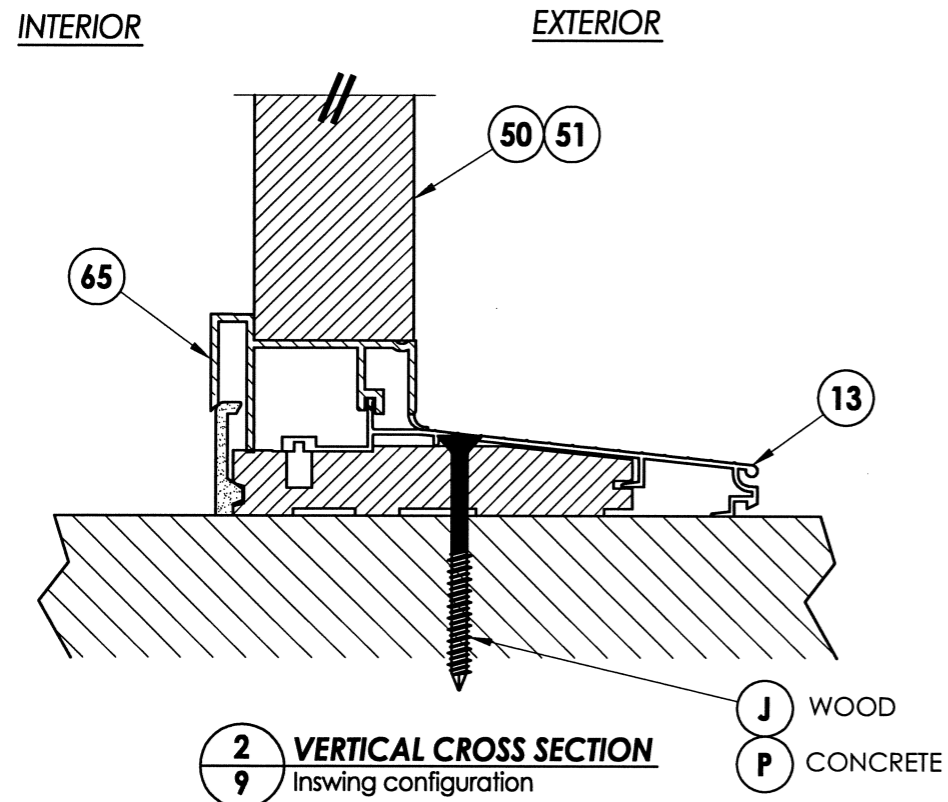

2 VERTICAL CROSS SECTION
9 Inswing configuration

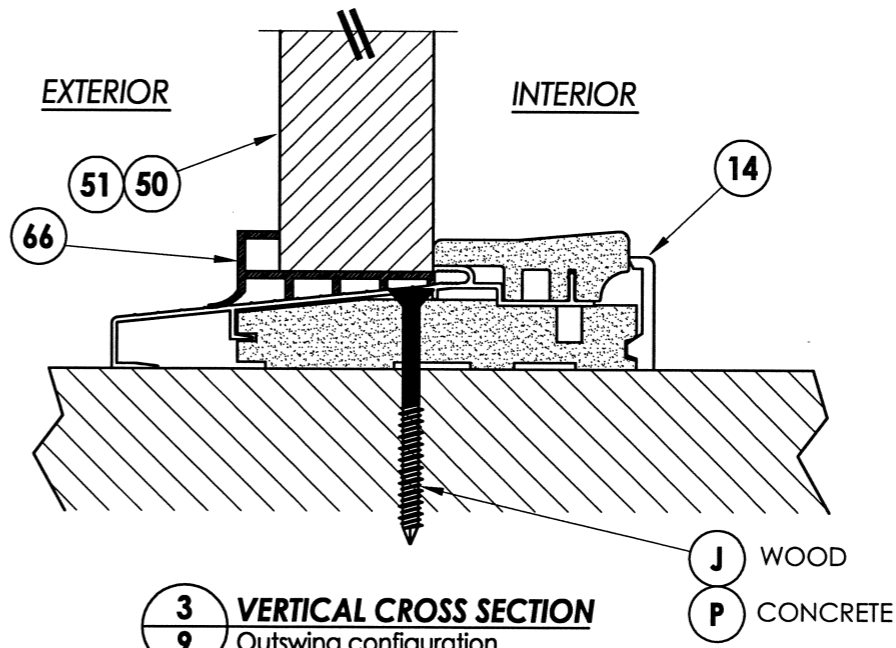

3 VERTICAL CROSS SECTION
9 Outswing configuration

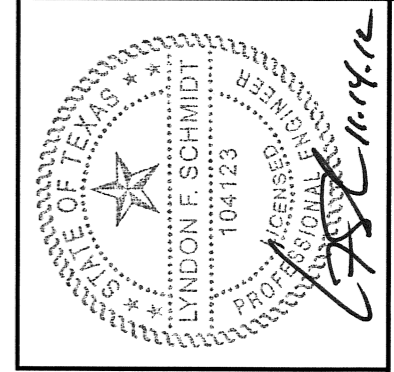

Documents Prepared By: Lyndon F. Schmidt, P.E.
 TEXAS P.E. #104123

RW BUILDING CONSULTANTS, INC.
 P.O. Box 230 Valrico FL 33595
 Phone No.: 813.659.9197

TEXAS BOARD OF PROFESSIONAL ENGINEERS
 CERTIFICATE OF REGISTRATION # F-11852

PRODUCT: THERMA-TRU FIBERGLASS DOOR
 PART OR ASSEMBLY: VERTICAL CROSS SECTIONS

NO.	DATE	BY	REVISIONS

DATE: 10/08/12
 SCALE: N.T.S.
 DWG. BY: JK
 CHK. BY: LFS
 DRAWING NO.: TX-4260
 SHEET 9 of 11

2X FRAMING TO BE DESIGNED BY THE ENGINEER OR ARCHITECT OF RECORD BASED ON WIND LOADS AND THE CLADDING BEING USED (TYP.).

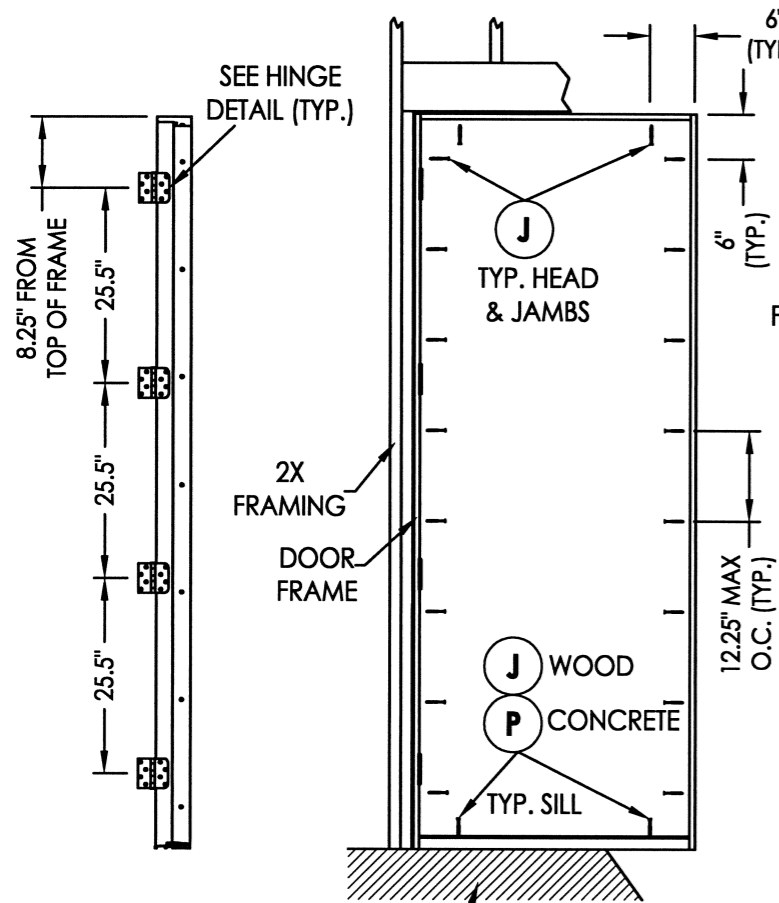

HINGE JAMB

FLOOR SUBSTRATE MATERIAL (TYP.)
 CONCRETE (MIN. 3000 PSI)
 WOOD (S.G. >= 0.42)

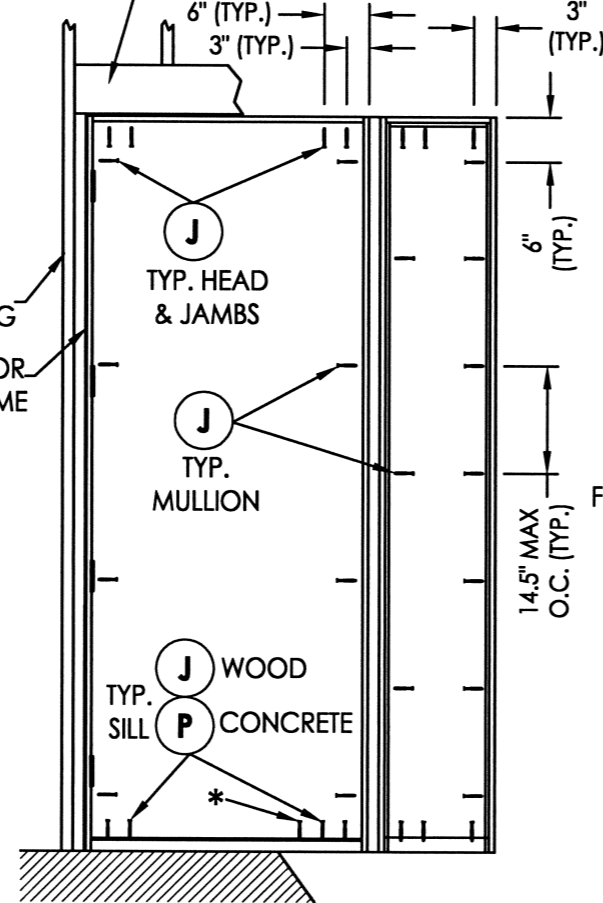
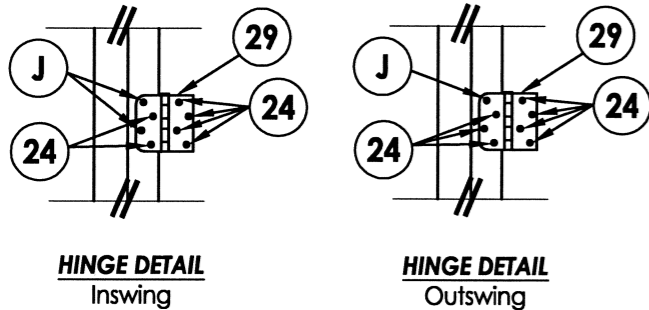

FRAME ANCHORING
XO / OX

*This anchor required for D.P > 60 psf.

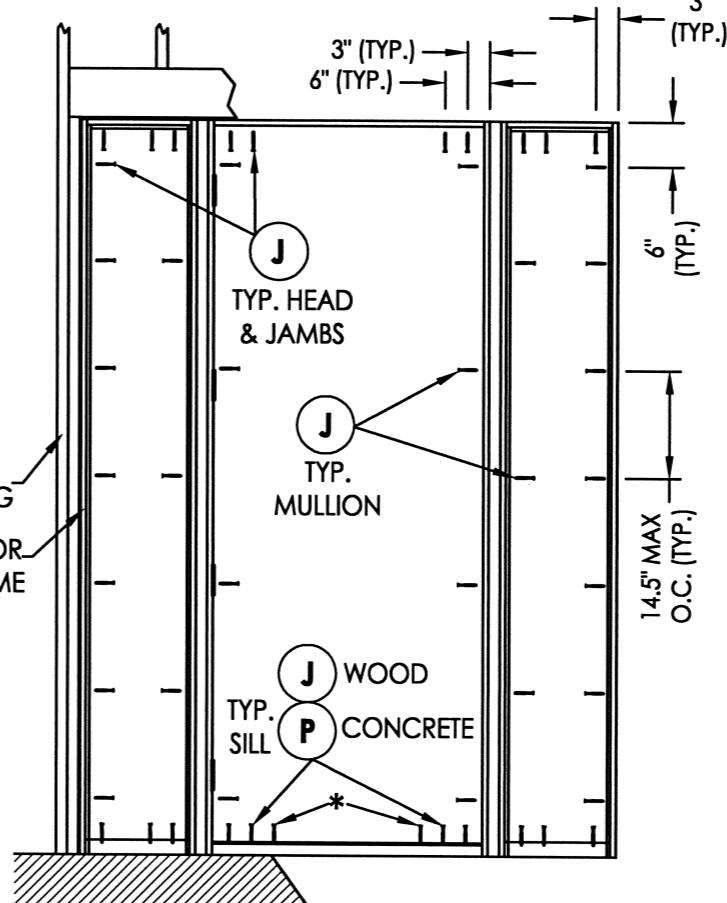

FRAME ANCHORING
OXO

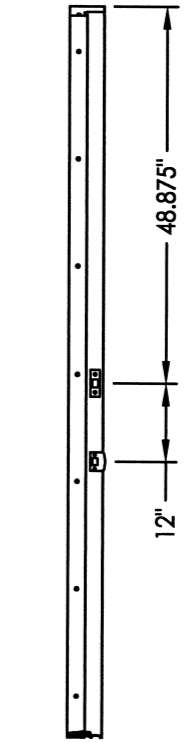
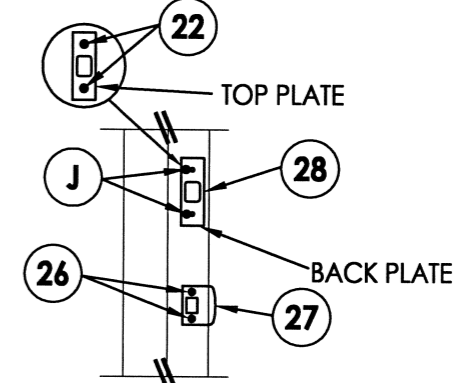
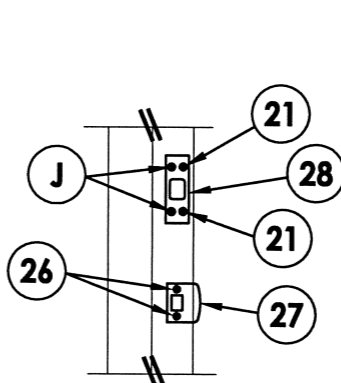

STRIKE JAMB

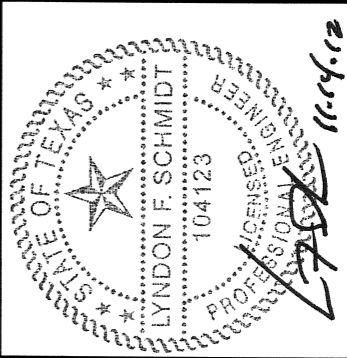

Documents Prepared By: Lyndon F. Schmidt, P.E.
 TEXAS P.E. #104123

RW BUILDING CONSULTANTS, INC.
 P.O. Box 230 Valrico FL 33595
 Phone No.: 813.659.9197

TEXAS BOARD OF PROFESSIONAL ENGINEERS
 CERTIFICATE OF REGISTRATION # F-11852

PRODUCT: THERMA-TRU FIBERGLASS DOOR
 PART OR ASSEMBLY: FRAME ANCHORING

NO.	DATE	BY

DATE: 10/08/12
 SCALE: N.T.S.
 DWG. BY: JK
 CHK. BY: LFS
 DRAWING NO.: TX-4260
 SHEET 10 OF 11

BILL OF MATERIALS		
ITEM #	DESCRIPTION	MATERIAL
B	2X BUCK (G >= 0.42)	WOOD
C	1/4" MAX. SHIM SPACE	-
J	#10 X 2-1/2" PFH WOOD SCREW (MIN. EMB. = 1.15" HEAD/JAMBS, 1-1/2" SILL)	STEEL
M	#10 X 2" PFH WOOD SCREW	STEEL
P	1/4" PFH ELCO OR ITW CONCRETE SCREW (1-3/4" MIN. EMB.)	STEEL
1	JAMB - FINGER JOINTED PINE	WOOD
7	WEATHERSTRIP (Long Reach by Therma-Tru)	FOAM
8	SWEEP	VINYL
9	WEATHERSTRIP (Medium Reach by Therma-Tru)	FOAM
13	INSWING THRESHOLD	ALUM/COMP
14	OUTSWING THRESHOLD	ALUM/COMP
21	#8 X 5/8" PFH WOOD SCREW	STEEL
22	10-32 X 3/8" PFH MACHINE SCREW	STEEL
24	#10 x 1" PFH WOOD SCREW	STEEL
26	#8 x 2" PFH WOOD SCREW	STEEL
27	LATCH STRIKE PLATE	STEEL
28	DEADBOLT STRIKE PLATE	STEEL
29	4" X 4" HINGE	STEEL
40	DOOR PANEL (SMOOTH STAR/FIBER CLASSIC)	-
41	DOOR PANEL (CLASSIC CRAFT)	-
50	SIDELITE PANEL (SMOOTH STAR/FIBER CLASSIC)	-
51	SIDELITE PANEL (CLASSIC CRAFT)	-
65	INSWING SIDELITE ADAPTER	PVC
66	OUTSWING SIDELITE ADAPTER	PVC
68	2X MULLION (G >= 0.55)	WOOD

CONCRETE ANCHOR NOTES:

- Concrete anchor locations at the corners may be adjusted to maintain the min. edge distance to mortar joints.
- Concrete anchor locations noted as "MAX. ON CENTER" must be adjusted to maintain the min. edge distance to mortar joints, additional concrete anchors may be required to ensure the "MAX. ON CENTER" dimension are not exceeded.
- Concrete anchor table:

ANCHOR TYPE	ANCHOR SIZE	MIN. EMBEDMENT	MIN. CLEARANCE TO MASONRY EDGE	MIN. CLEARANCE TO ADJACENT ANCHOR
ITW TAPCON®	1/4"	1-3/4"	2-1/2"	3"
ELCO ULTRACON®	1/4"	1-3/4"	1"	3"

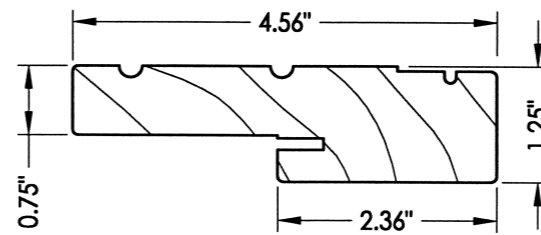

1 WOOD JAMB

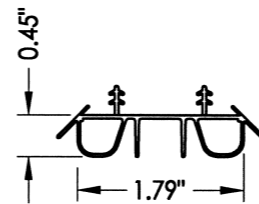

8 SWEEP

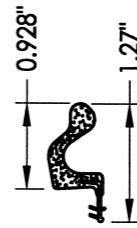

7 WEATHERSTRIP Long Reach

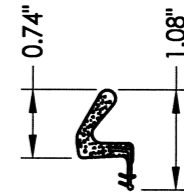

9 WEATHERSTRIP Medium Reach

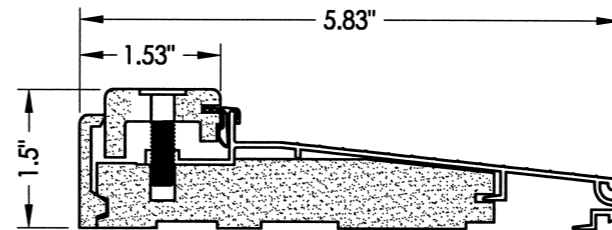

13 INSWING THRESHOLD

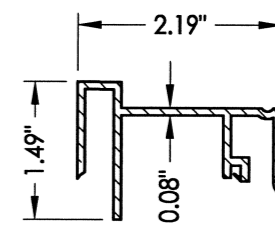

65 INSWING SIDELITE ADAPTER

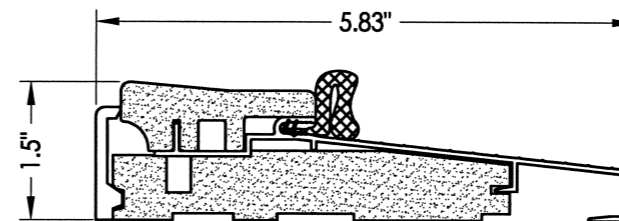

14 OUTSWING THRESHOLD

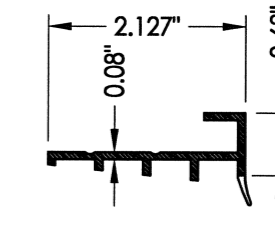

66 OUTSWING SIDELITE ADAPTER

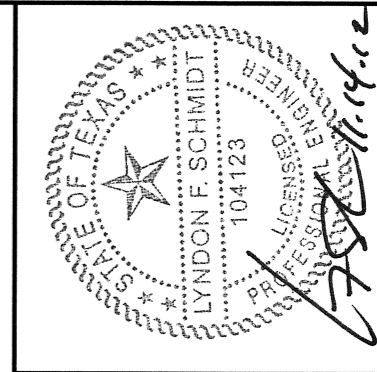

Documents Prepared By: Lyndon F. Schmidt, P.E.
TEXAS P.E. #104123

RW BUILDING CONSULTANTS, INC.
P.O. Box 230 Vairico FL 33595
Phone No.: 813.659.9197

TEXAS BOARD OF PROFESSIONAL ENGINEERS
CERTIFICATE OF REGISTRATION # F-11852

PRODUCT: THERMA-TRU FIBERGLASS DOOR
PART OR ASSEMBLY: BILL OF MATERIALS & COMPONENTS

NO.	DATE	BY	REVISIONS

DATE: 10/08/12
SCALE: N.T.S.
DWG. BY: JK
CHK. BY: LFS
DRAWING NO.: TX-4260
SHEET 11 of 11