

# THERMA TRU®

118 INDUSTRIAL DR., EDGERTON, OH 43517  
TEL. (419)298-1740

## "SMOOTH STAR", "FIBER CLASSIC", "CLASSIC CRAFT" & "CLASSIC CRAFT RUSTIC" GLAZED FIBERGLASS DOOR W/SIDELITES IN SWING / OUT SWING "IMPACT"

### EVALUATED FOR USE IN THE STATE OF TEXAS

THE THERMA-TRU FIBERGLASS DOOR DESCRIBED HEREIN COMPLIES WITH THE INTERNATIONAL RESIDENTIAL CODE (IRC), SECTIONS R301 & R613 AND THE INTERNATIONAL BUILDING CODE (IBC), SECTIONS 1714.5 1405.12, 1609, 2403 AND 2404 (INCLUDING TEXAS REVISIONS) SUBJECT TO THE FOLLOWING CONDITIONS:

1. Anchors shall be as listed and spaced as shown in the details. Anchor embedment to base material shall be beyond wall dressing or stucco.
2. When used in wind borne debris regions (SEAWARD and INLAND I ZONES), the Product complies with Sections R301.2.1.2 and 1609.1.4 as an impact resistant product and does not require the use of an approved impact resistant covering. This product does not meet the requirements for enhanced protection of essential facilities as defined in ASTM E1996.
3. Allowable design pressure requirements must be equal to or less than the design pressure rating shown in the design pressure chart, sheet 1 of this drawing.
4. Conditions not covered by this drawing are subject to further engineering analysis.

### SUPPORTING DOCUMENTS & EVIDENCE

1. Testing per AAMA 101/I.S.2/A440-05, ASTM E1886-02 and ASTM E1996-02 as performed by Testing Evaluation Laboratories Inc. and report number TEL 06-0718-1, dated July 17, 2006 and signed by Wendell W. Haney, P.E.
2. Testing per TAS 201-94, TAS 202-94 and TAS 203-94 as performed by Testing Evaluation Laboratories Inc. and reported in test report number TEL 06-1031-4, November 9, 2006 and signed by Wendell W. Haney, P.E.
3. Anchor analysis for loading conditions prepared, signed and sealed by Wendell W. Haney, P.E. Glass load resistance report ASTM E1300-00, prepared by Wendell W. Haney, P.E..
4. Certificate of Participation issued by the National Accreditation and Management Institute, Inc., certifying that Therma Tru Corporation is manufacturing products within a Quality Assurance program.

### TABLE OF CONTENTS

SHEET #	DESCRIPTION
1	TYPICAL ELEVATION, DESIGN PRESSURES & GENERAL NOTES
2	DOOR & SIDELITE PANEL CROSS SECTIONS "SMOOTH STAR"
3	DOOR & SIDELITE PANEL CROSS SECTIONS "CLASSIC CRAFT" & "RUSTIC"
4	DOOR & SIDELITE PANEL CROSS SECTIONS "FIBER CLASSIC"
5	HORIZONTAL CROSS SECTIONS
6	VERTICAL CROSS SECTIONS
7	VERTICAL CROSS SECTIONS
8	FRAME ANCHORING
9	BILL OF MATERIALS & COMPONENTS

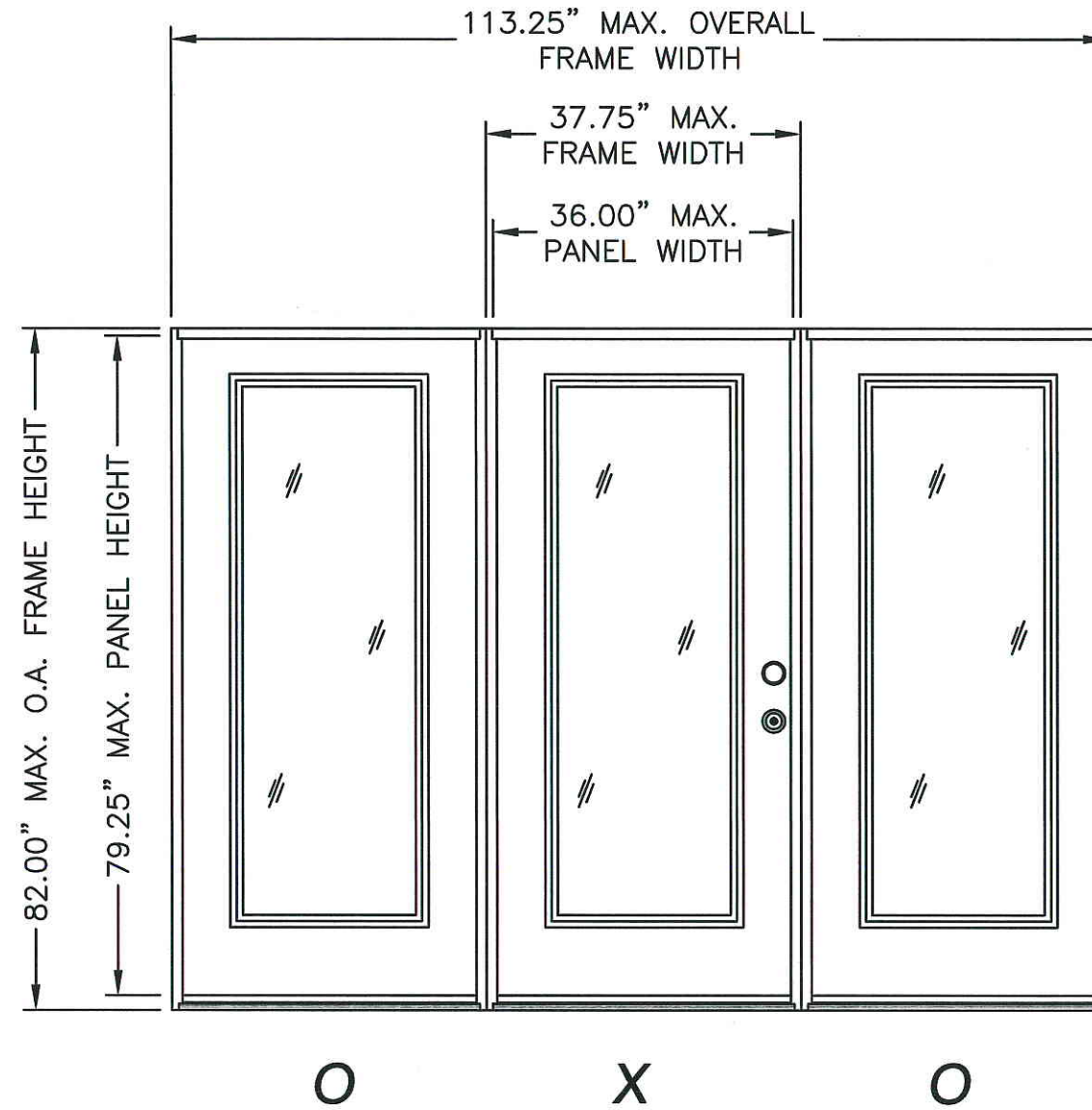

"SMOOTH STAR", "FIBER CLASSIC"  
"CLASSIC CRAFT" & "CLASSIC CRAFT RUSTIC"

SWING	OVERALL FRAME DIMENSION	OVERALL D.L.O. DOOR / SIDELITE DIMENSION	DESIGN PRESSURE (PSF)	
			POSITIVE	NEGATIVE
IN SWING	113.25" X 82.00"	21.00" X 63.25"	+49.2	-50.0
OUT SWING	113.25" X 80.62"	21.00" X 63.25"	+49.2	-50.0

Documents Prepared By:  
**R.W.** BUILDING CONSULTANTS, INC.  
P.O. Box 230 Vairico FL, 33595  
Phone No.: 813.659.9197  
Florida Board of Professional Engineers  
Certificate of Authorization No. 9813  
Wendell W. Haney, P.E. No. 54158

PRODUCT: THERMA-TRU FIBERGLASS DOOR W/  
GLAZED FIBERGLASS DOOR W/  
SIDELITES IN/OUTSWING "IMPACT"  
PART OR ASSEMBLY:  
TYPICAL ELEVATION, DESIGN  
PRESSURES & GENERAL NOTES

NO.	DATE	REV. LOCK & DEADBOLT MODEL	AL	BY
1	7/9/08			

DATE: 12/15/06  
SCALE: N.T.S.  
DWG. BY: AEM  
CHK. BY: WWH  
DRAWING NO.: TX-3182  
SHEET 1 OF 9

R:\A - Projects\Project Folders\Proj 1101 - 1200\p1105\DWG. RWBC Drawings\TX-3182\TX-3182 REV 1\TX-3182-2.DWG, Model

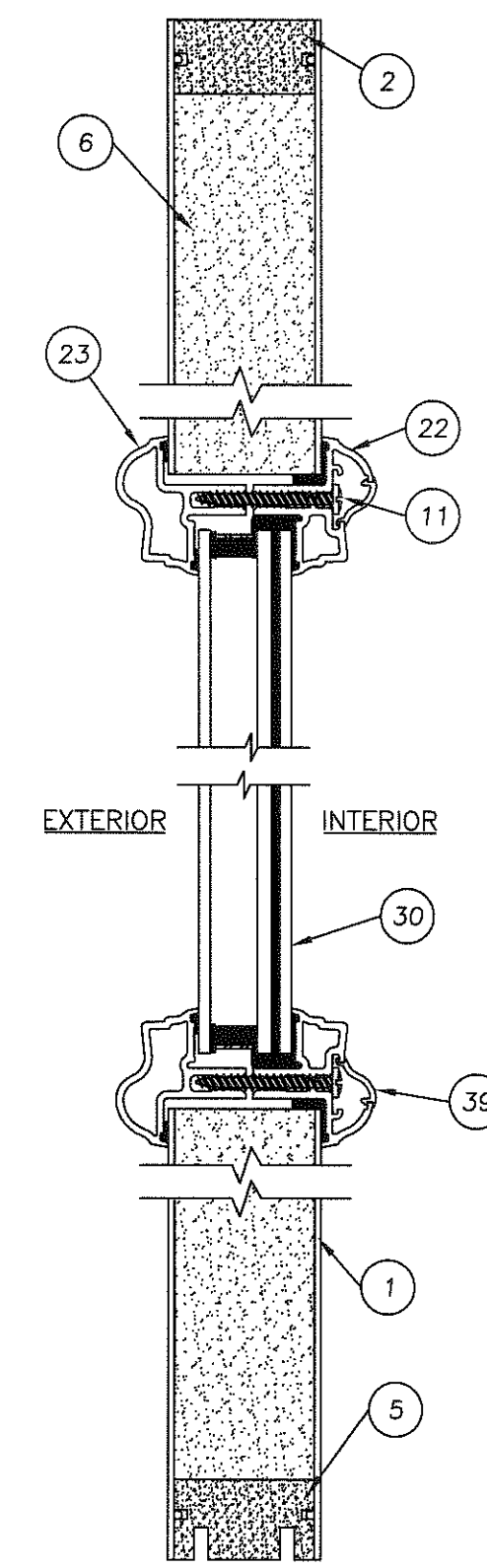
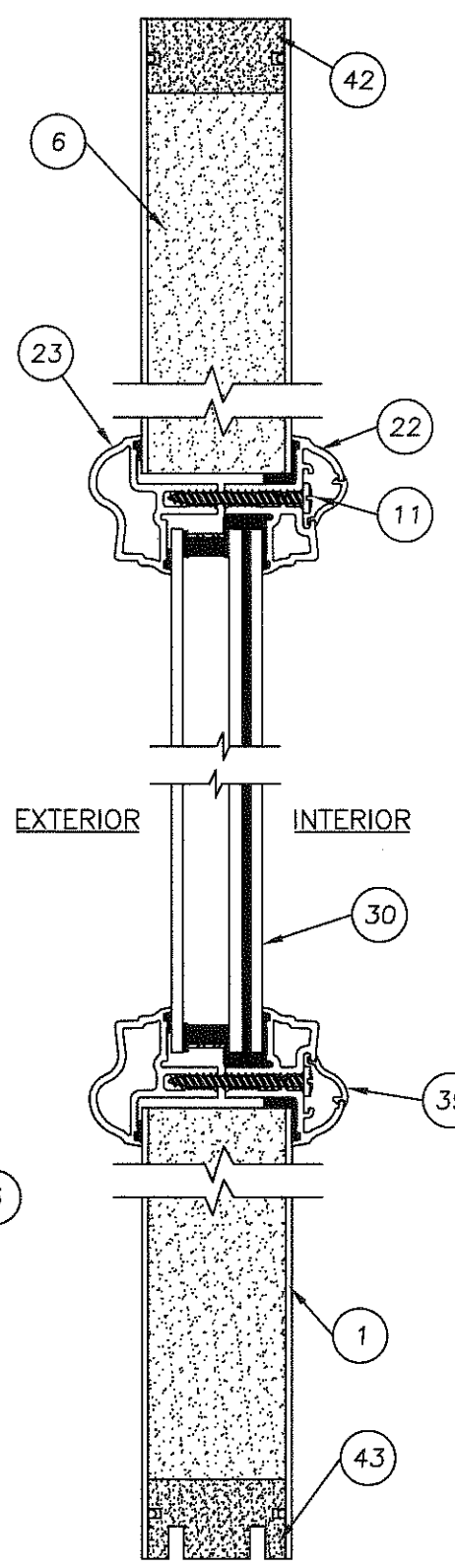
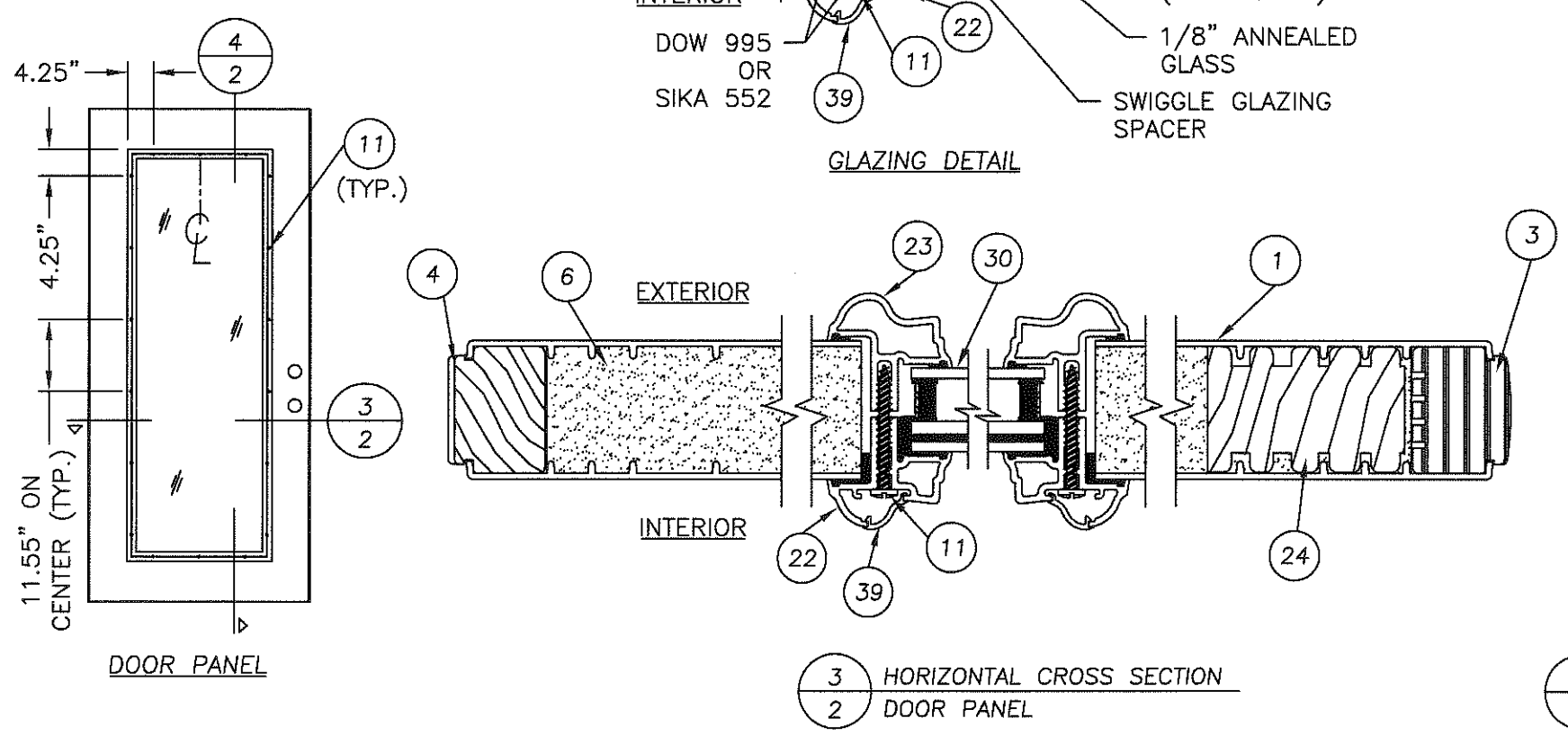
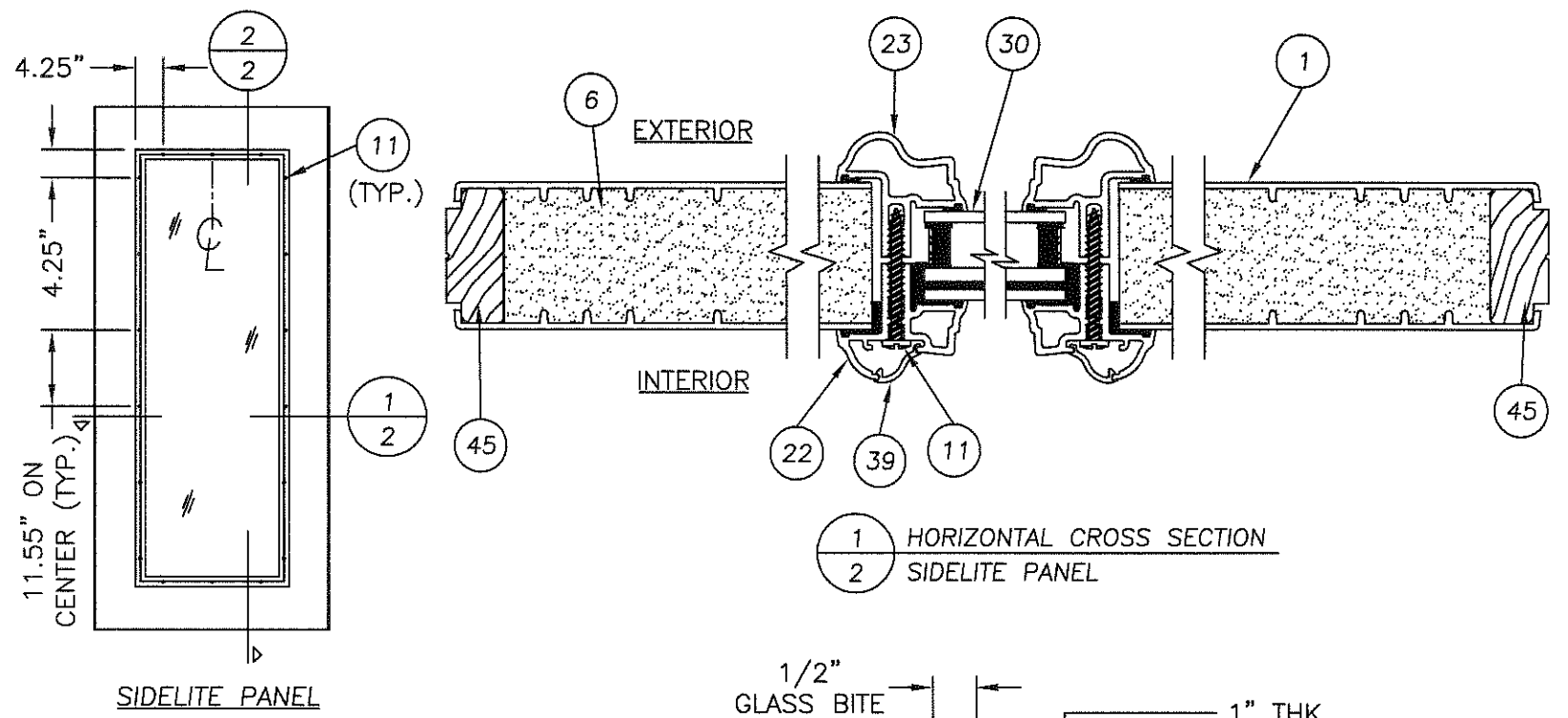

Documents Prepared By:  
**RW** BUILDING CONSULTANTS, INC.  
 P.O. Box 230 Valrico FL 33595  
 Phone No.: 813.659.9197  
 Florida Board of Professional Engineers  
 Certificate of Authorization No. 9813  
*Wendell W. Honey* 7-23-08  
 Wendell W. Honey, P.E. No. 54158

PRODUCT:  
 THERMA-TRU  
 GLAZED FIBERGLASS DOOR W/  
 SIDELITES IN/OUTSWING "IMPACT"  
 PART OR ASSEMBLY:  
 "SMOOTH STAR" DOOR/SIDELITE  
 PANEL CROSS SECTIONS

NO.	DATE	REV.	LOCK & DEADBOLT MODEL	AL	BY
1	7/9/08				

REVISIONS

DATE: 12/15/06  
 SCALE: N.T.S.  
 DWG. BY: AEM  
 CHK. BY: WWH  
 DRAWING NO.: TX-3182  
 SHEET 2 of 9

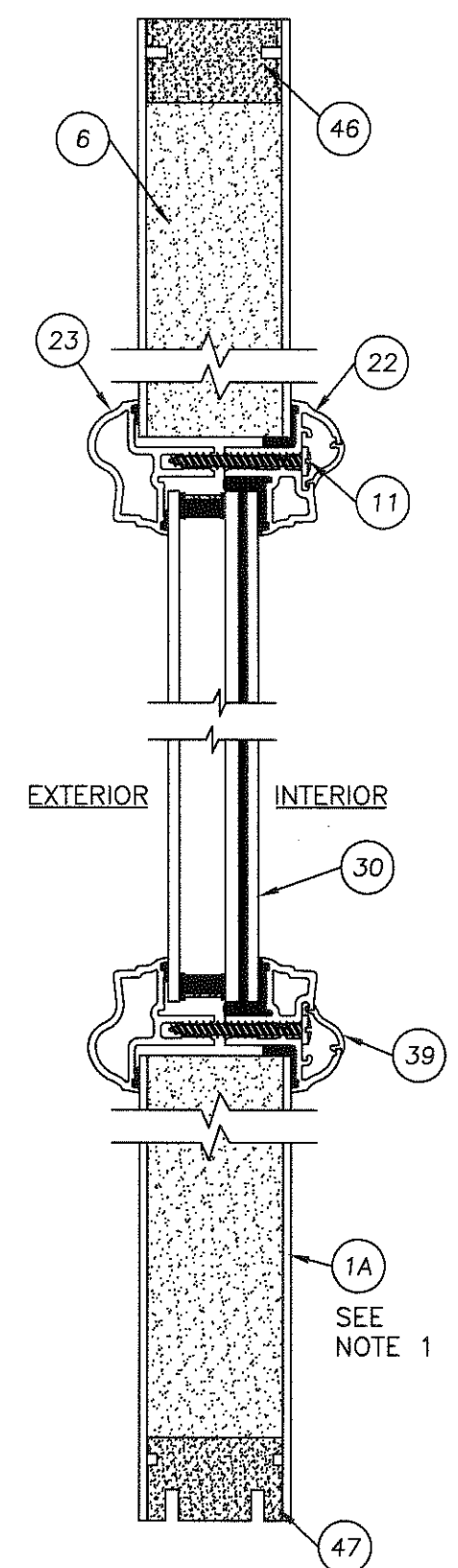
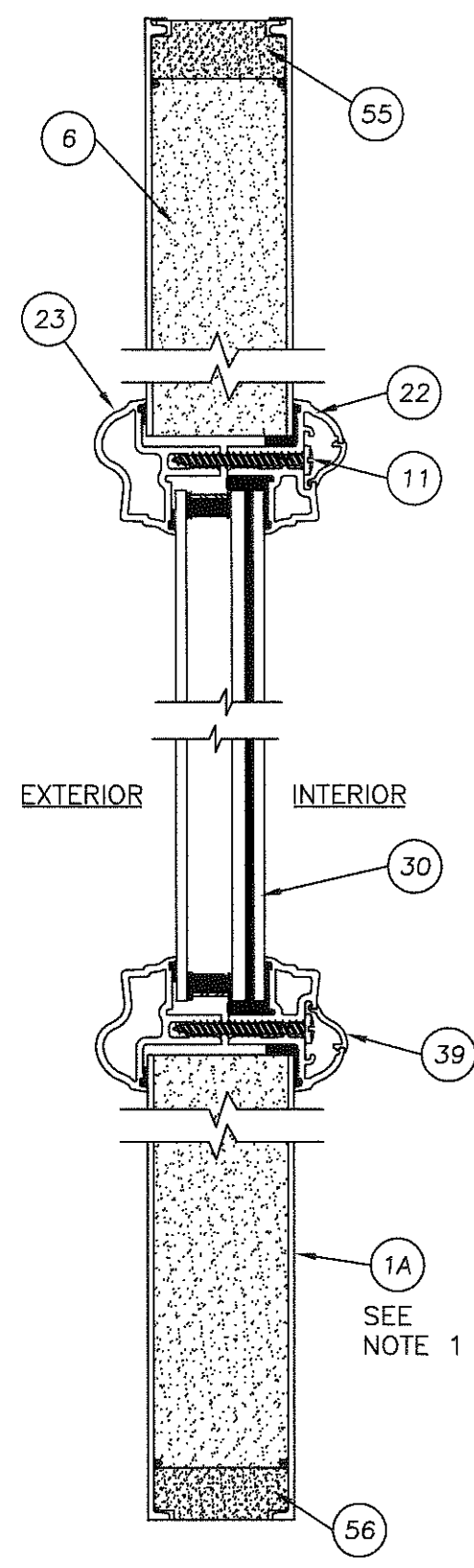
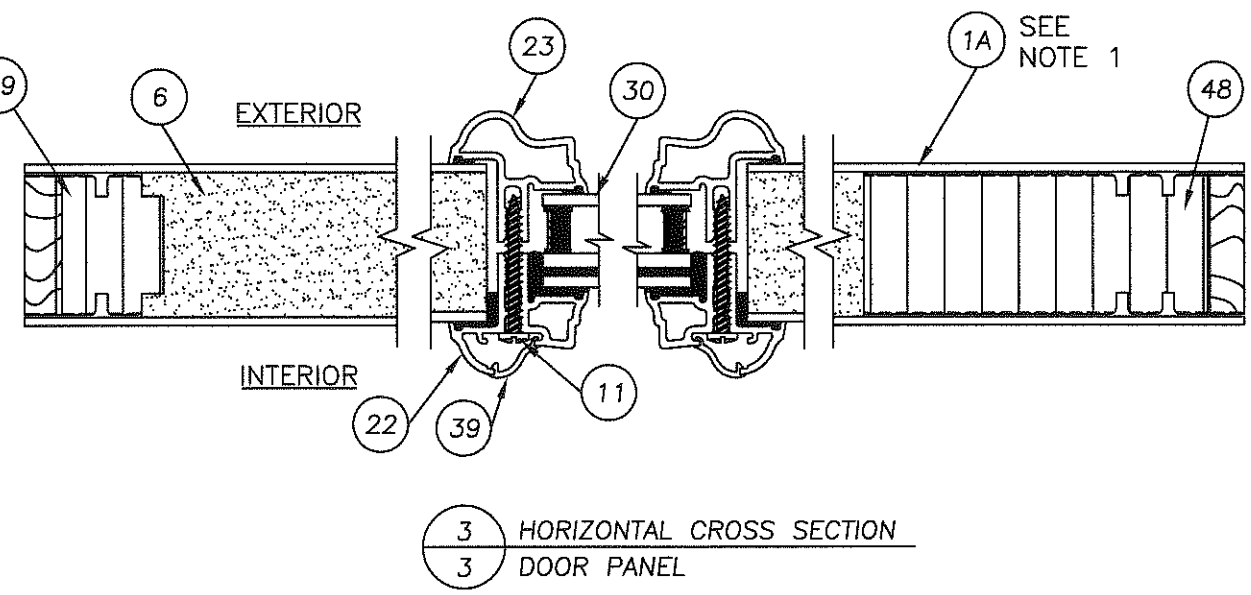
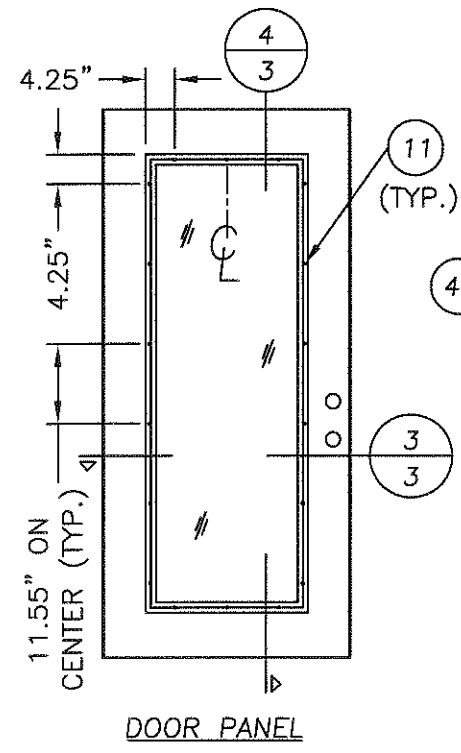
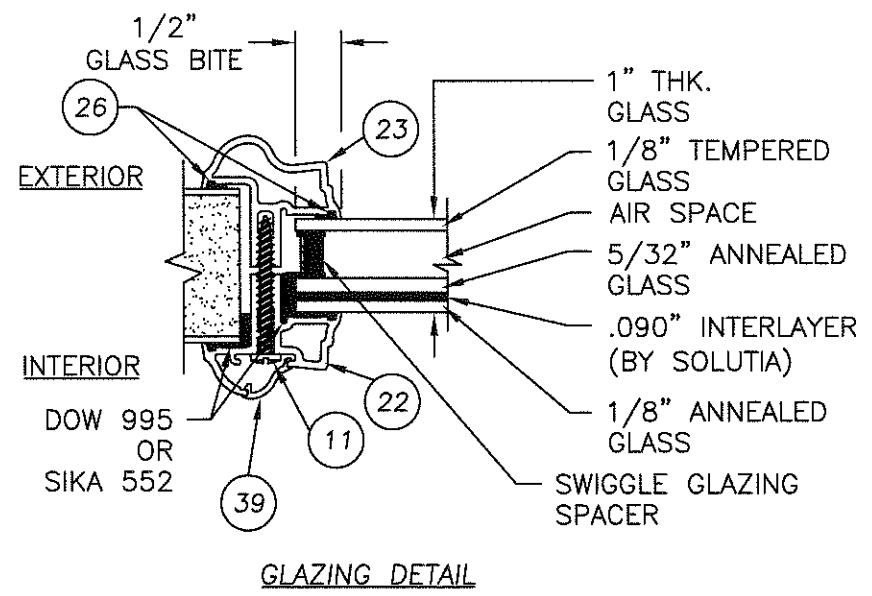
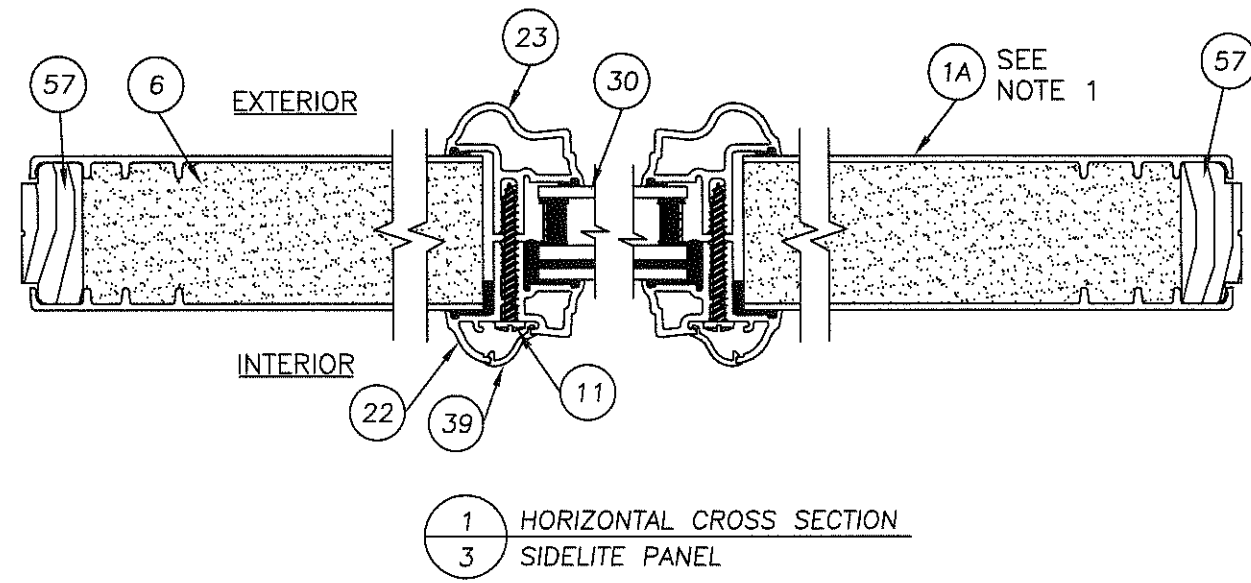
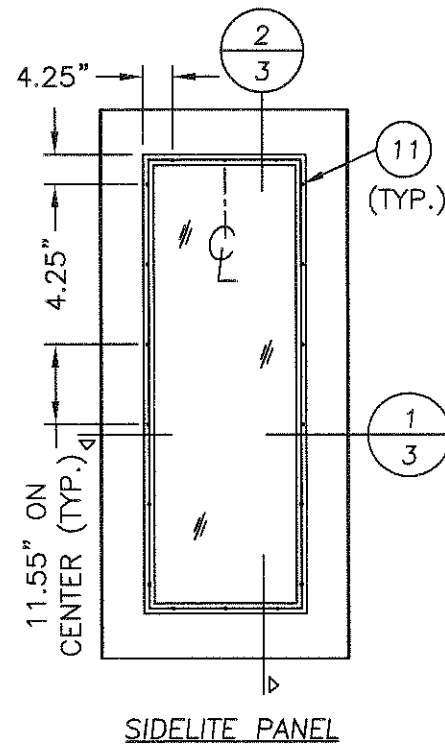

NOTE:  
1. "RUSTIC" PANEL UTILIZES MAHOGANY GRAINING PATTERN, "CLASSIC CRAFT" PANEL UTILIZES OAK GRAINING PATTERN.

Documents Prepared By:  
R.W. BUILDING CONSULTANTS, INC.  
P.O. Box 230 Valrico FL 33595  
Phone No.: 813.659.9197  
Florida Board of Professional Engineers  
Certificate of Authorization No. 9813  
Wendell W. Holroyd 7-23-08  
Wendell W. Holroyd, P.E. No. 54158

PRODUCT:	THERMA-TRU GLAZED FIBERGLASS DOOR W/ SIDELITES IN/OUTSWING "IMPACT"				
PART OR ASSEMBLY:	"CLASSIC CRAFT" & "RUSTIC" DOOR PANEL CROSS SECTIONS				
NO	DATE	REV.	LOCK & DEADBOLT MODEL	AL	BY
1	7/9/08				
REVISIONS					
DATE: 12/15/06					
SCALE: N.T.S.					
DWG. BY: AEM					
CHK. BY: WWH					
DRAWING NO.: TX-3182					
SHEET 3 OF 9					

© 2008 R.W. BUILDING CONSULTANTS INC.

R:\A - Projects\Project Folders\Proj 1101 - 1200\p1105\1105.D. RWBC Drawings\TX-3182\TX-3182 REV 1\TX-3182-4.DWG, Model

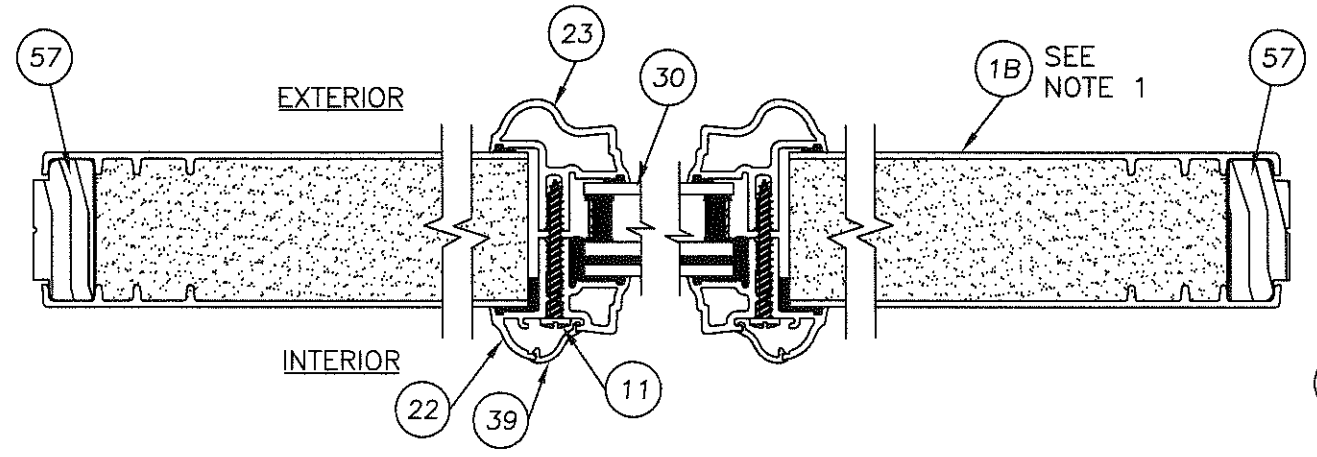
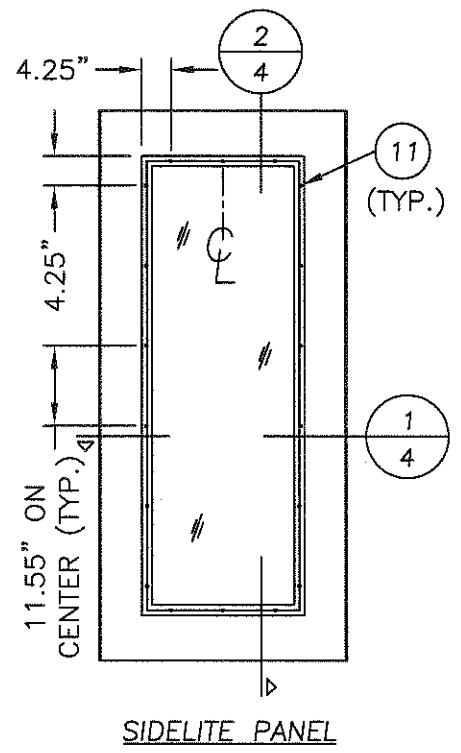

1 HORIZONTAL CROSS SECTION  
4 SIDELITE PANEL

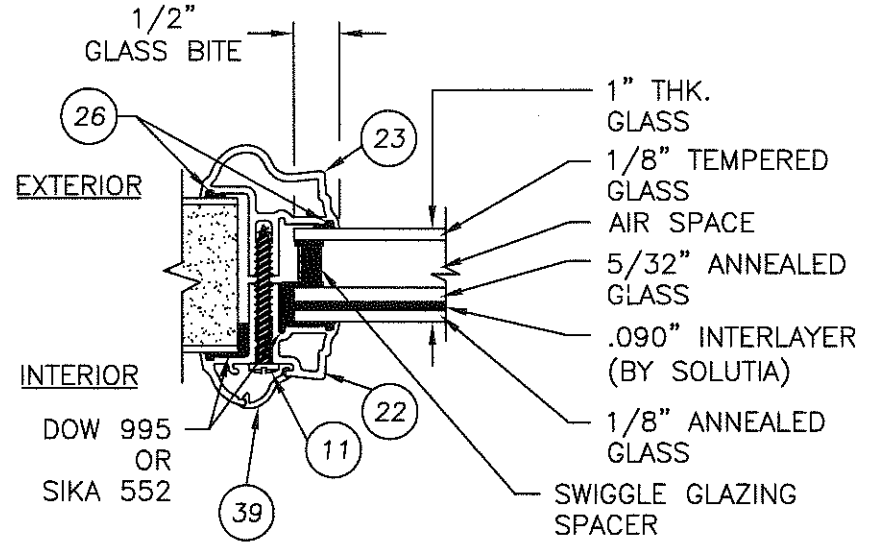

GLAZING DETAIL

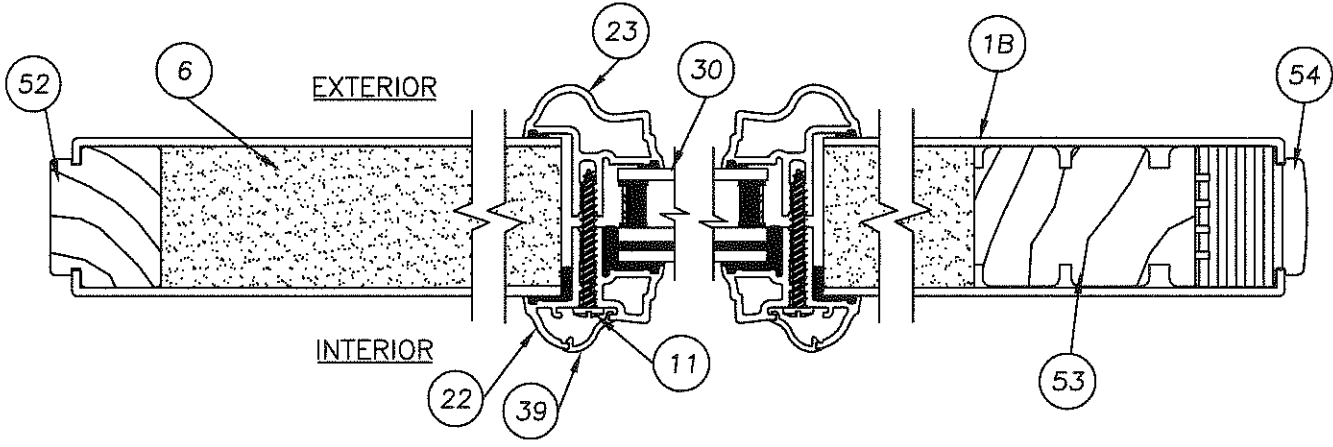
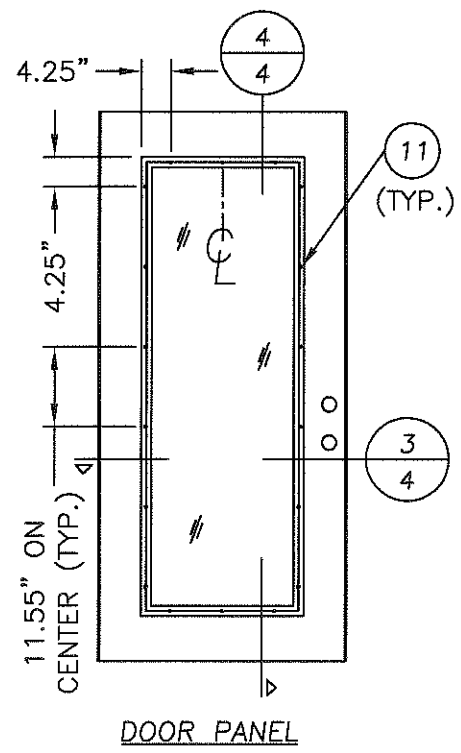

3 HORIZONTAL CROSS SECTION  
4 DOOR PANEL

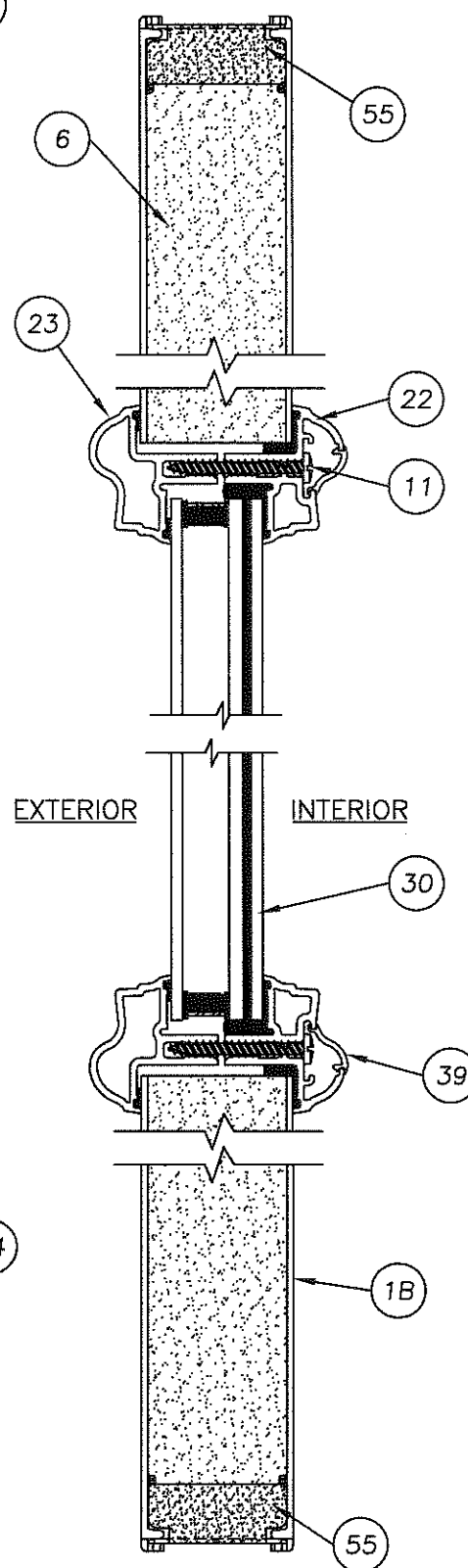

2 VERTICAL CROSS SECTION  
4 SIDELITE PANEL

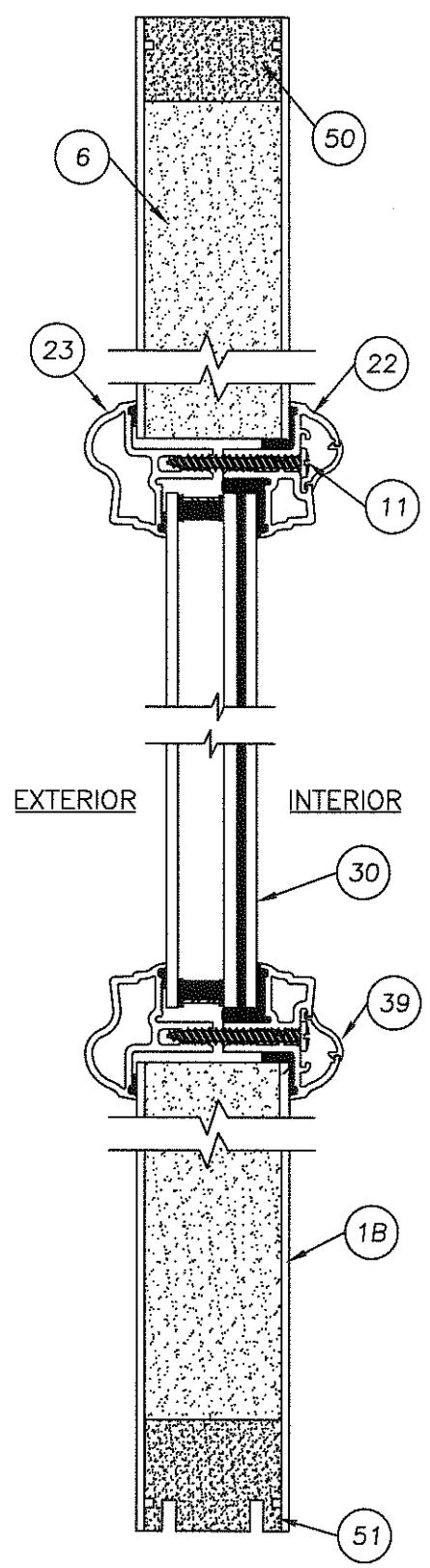

4 VERTICAL CROSS SECTION  
4 DOOR PANEL

Documents Prepared By:  
**RW** BUILDING CONSULTANTS, INC.  
 P.O. Box 230 Vairico FL 33595  
 Phone No.: 813.659.9197  
 Florida Board of Professional Engineers  
 Certificate of Authorization No. 9813  
*Wendell W. Haney* 7-23-08  
 P.E. No. 54158

PRODUCT: THERMA-TRU GLAZED FIBERGLASS DOOR W/ SIDELITES IN/OUTSWING "IMPACT"  
 PART OR ASSEMBLY: "FIBER CLASSIC" DOOR/SIDELITE PANEL CROSS SECTIONS

NO.	DATE	REV. LOCK & DEADBOLT MODEL	AL	BY
1	7/9/08			

REVISIONS

DATE: 12/15/06  
 SCALE: N.T.S.  
 DWG. BY: AEM  
 CHK. BY: WWH  
 DRAWING NO.: TX-3182  
 SHEET 4 OF 9

© 2008 R.W. BUILDING CONSULTANTS INC.

K:\A - Projects\Project folders\proj 1101 - 1200\proj1105\10. RWBC Drawings\1X-3182\1X-3182 REV 1\1X-3182-5.DWG, Model

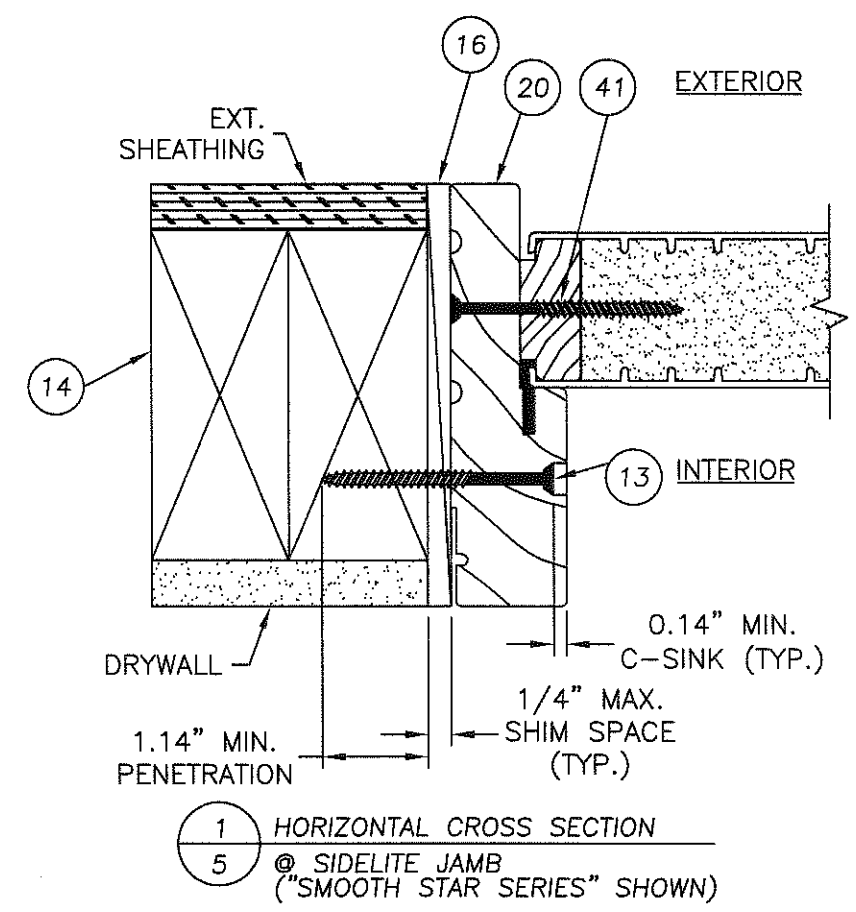
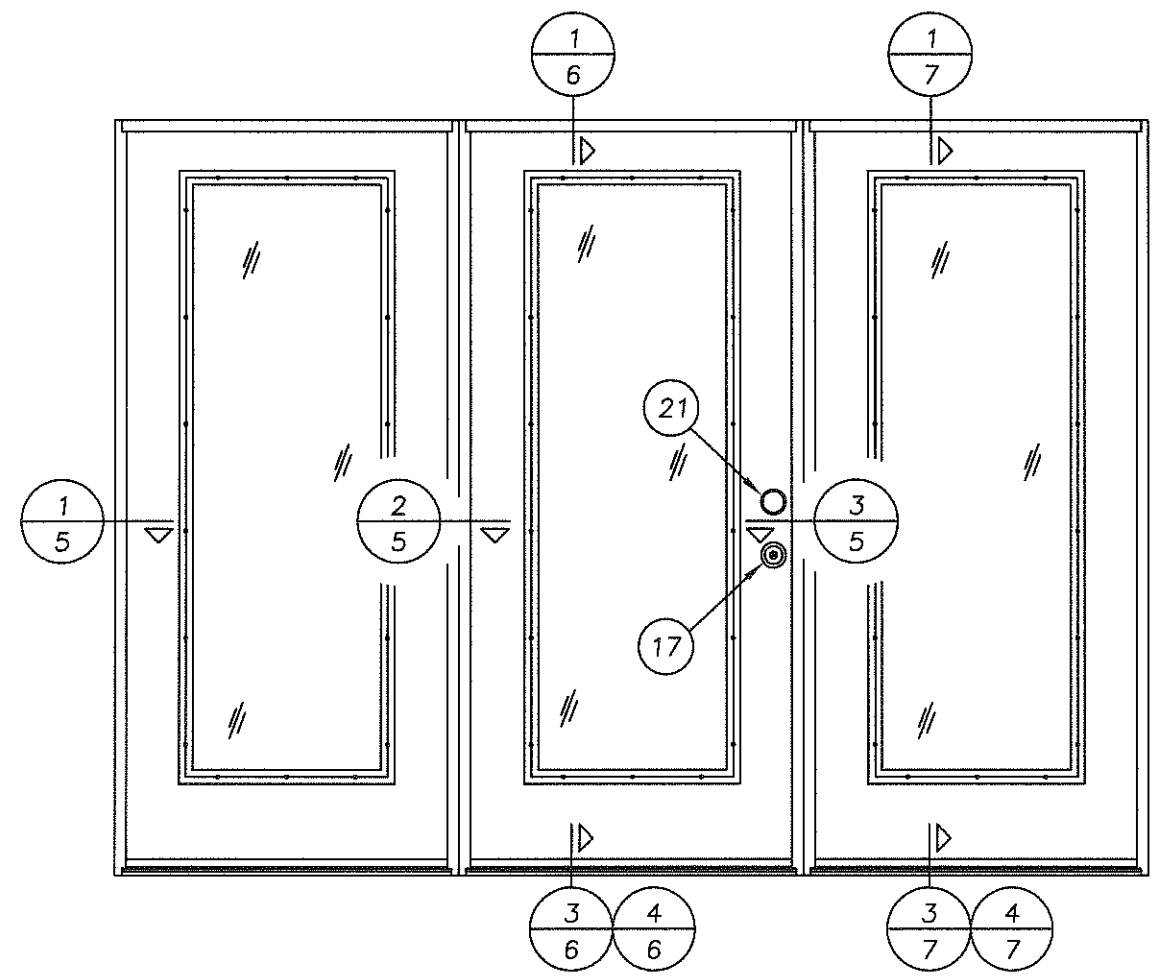

1 HORIZONTAL CROSS SECTION  
5 @ SIDELITE JAMB  
("SMOOTH STAR SERIES" SHOWN)

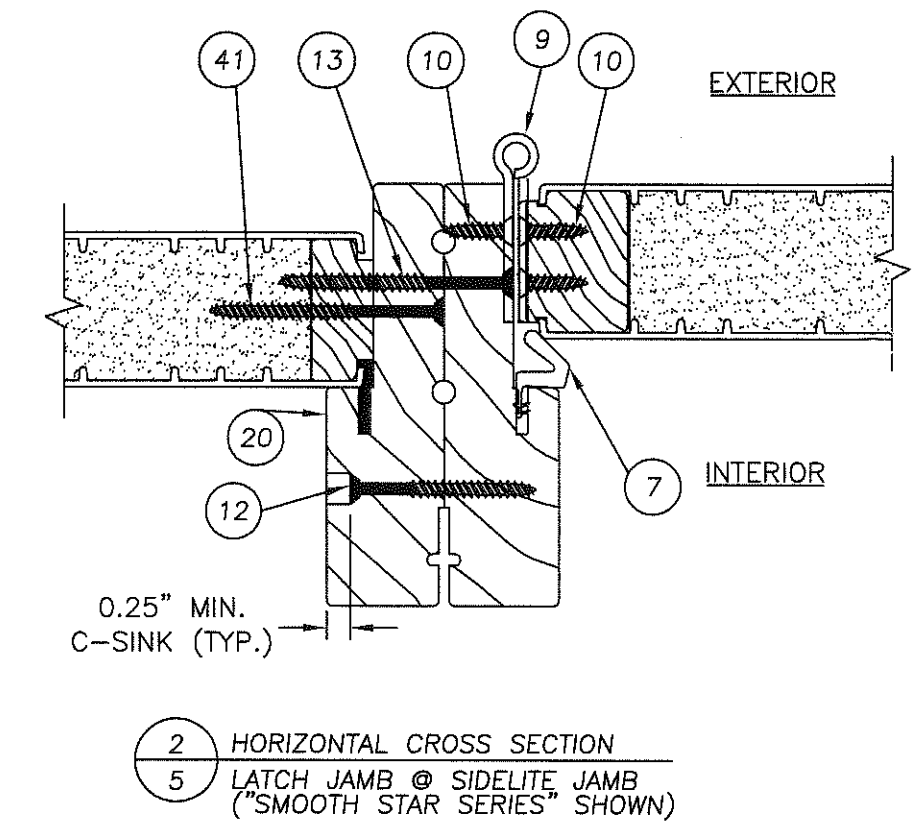

2 HORIZONTAL CROSS SECTION  
5 LATCH JAMB @ SIDELITE JAMB  
("SMOOTH STAR SERIES" SHOWN)

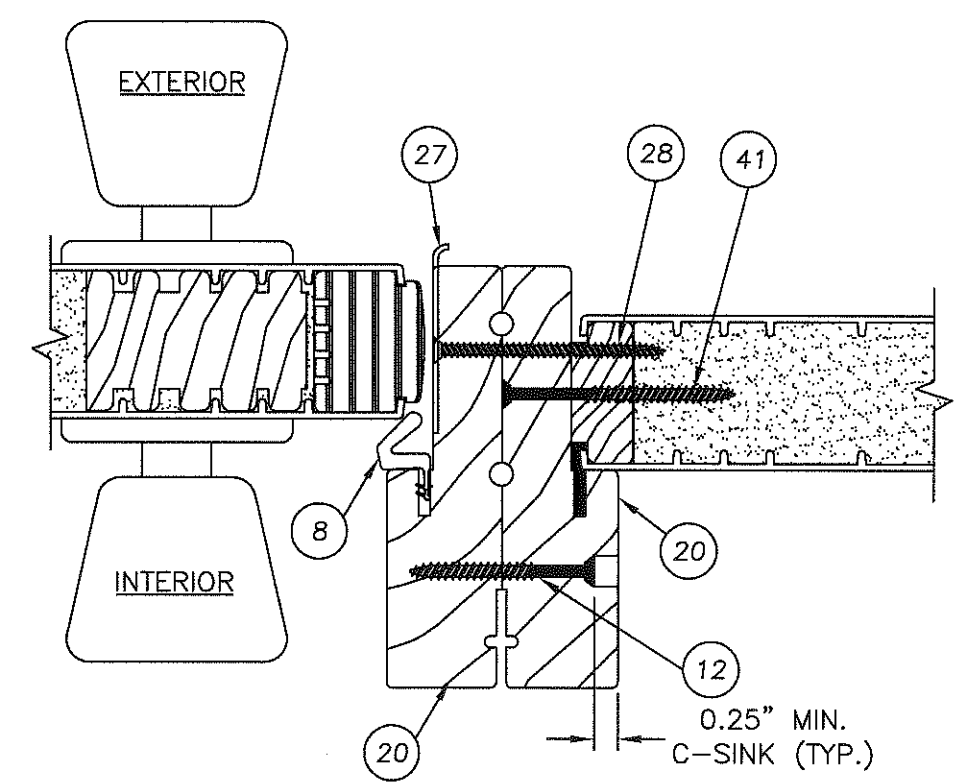

3 HORIZONTAL CROSS SECTION  
5 LATCH JAMB @ SIDELITE JAMB  
("SMOOTH STAR SERIES" SHOWN)

Documents Prepared By:  
**RW** BUILDING CONSULTANTS, INC.  
 P.O. Box 230 Valrico FL 33595  
 Phone No.: 813.659.9197  
 Florida Board of Professional Engineers  
 Certificate Of Authorization No. 9813  
*Wendell W. Haney* 7/9/08  
 Wendell W. Haney, P.E. No. 54158

PRODUCT: THERMA-TRU GLAZED FIBERGLASS DOOR S/  
 SIDELITES IN/OUTSWING "IMPACT"  
 PART OR ASSEMBLY: HORIZONTAL CROSS SECTIONS

NO.	DATE	REV.	LOCK & DEADBOLT MODEL	AL	BY
1	7/9/08				

REVISIONS

DATE: 12/15/06  
 SCALE: N.T.S.  
 DWG. BY: AEM  
 CHK. BY: WWH  
 DRAWING NO.: TX-3182  
 SHEET 5 OF 9

© 2008 R.W. BUILDING CONSULTANTS INC.

K:\A - Projects\Project Folders\Proj 1101 - 1200\p1105\1D. RWBC Drawings\TX-3182\TX-3182 REV 1\TX-3182-6.DWG, Model

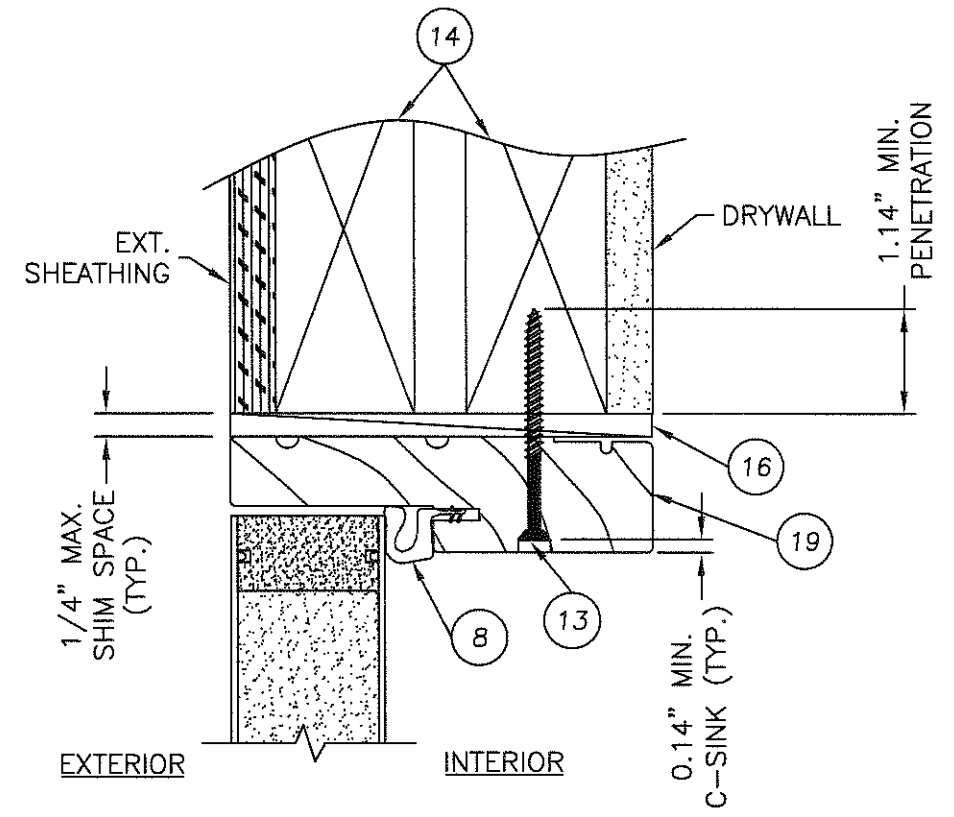

1 VERTICAL CROSS SECTION  
6 ("SMOOTH STAR SERIES" SHOWN)

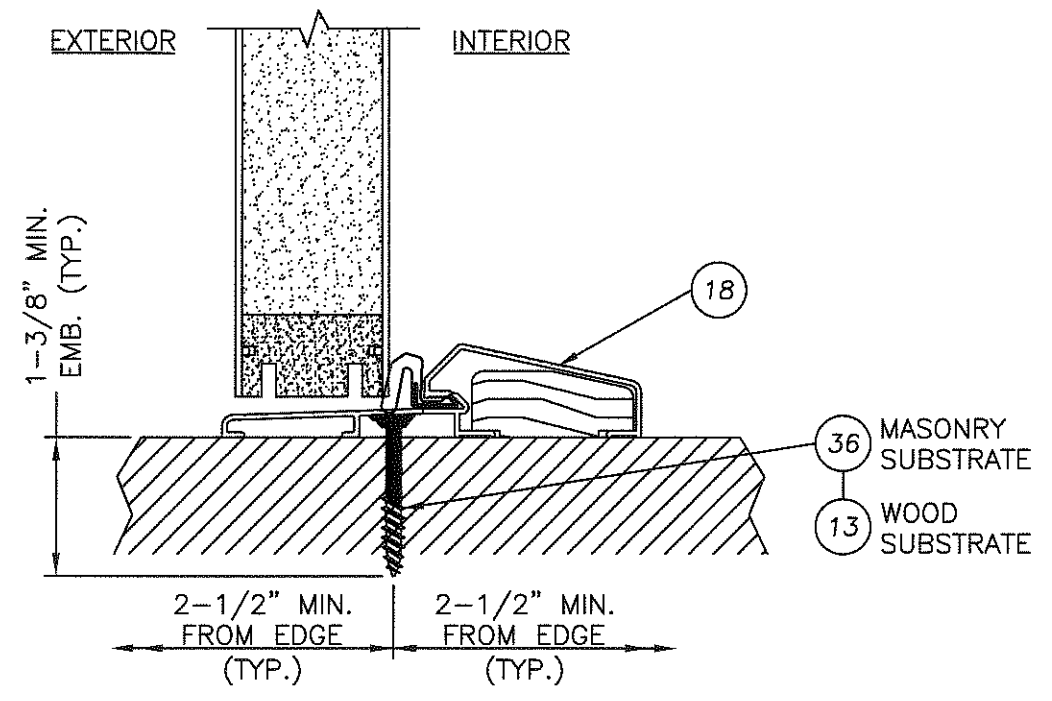

3 VERTICAL CROSS SECTION  
6 OUTSWING CONFIGURATION ("SMOOTH STAR SERIES" SHOWN)

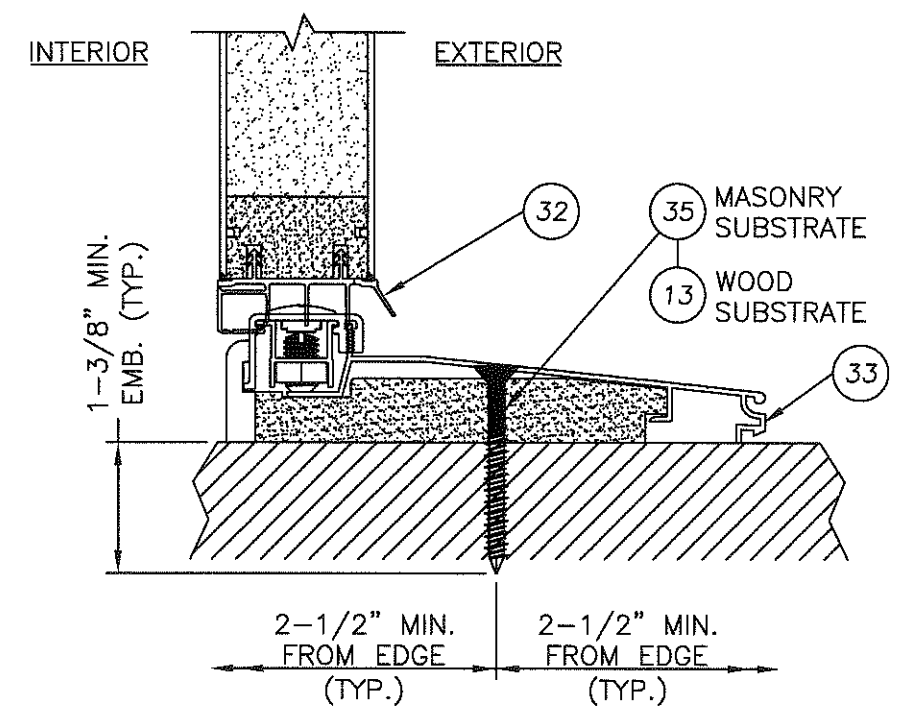

4 VERTICAL CROSS SECTION  
6 INSWING CONFIGURATION ("SMOOTH STAR SERIES" SHOWN)

Documents Prepared By:  
**RW** BUILDING CONSULTANTS, INC.  
P.O. Box 230 Valrico FL, 33595  
Phone No.: 813.659.9197  
Florida Board of Professional Engineers  
Certificate Of Authorization No. 9813  
*Wendell W. Hahn* 7-23-08  
Wendell W. Hahn, P.E. No. 54158

PRODUCT: THERMA-TRU GLAZED FIBERGLASS DOOR W/ SIDELITES IN/OUTSWING "IMPACT"  
PART OR ASSEMBLY: VERTICAL CROSS SECTIONS

NO.	DATE	REV. LOCK & DEADBOLT MODEL	AL	BY
1	7/9/08			

REVISIONS

DATE: 12/15/06  
SCALE: N.T.S.  
DWG. BY: AEM  
CHK. BY: WWH  
DRAWING NO.: TX-3182  
SHEET 6 OF 9

© 2008 R.W. BUILDING CONSULTANTS INC.

K:\A - Projects\Project Folders\Proj 1101 - 1200\pt1105\1D. RWBC Drawings\TX-3182\TX-3182 REV 1\TX-3182-7.DWG, Model

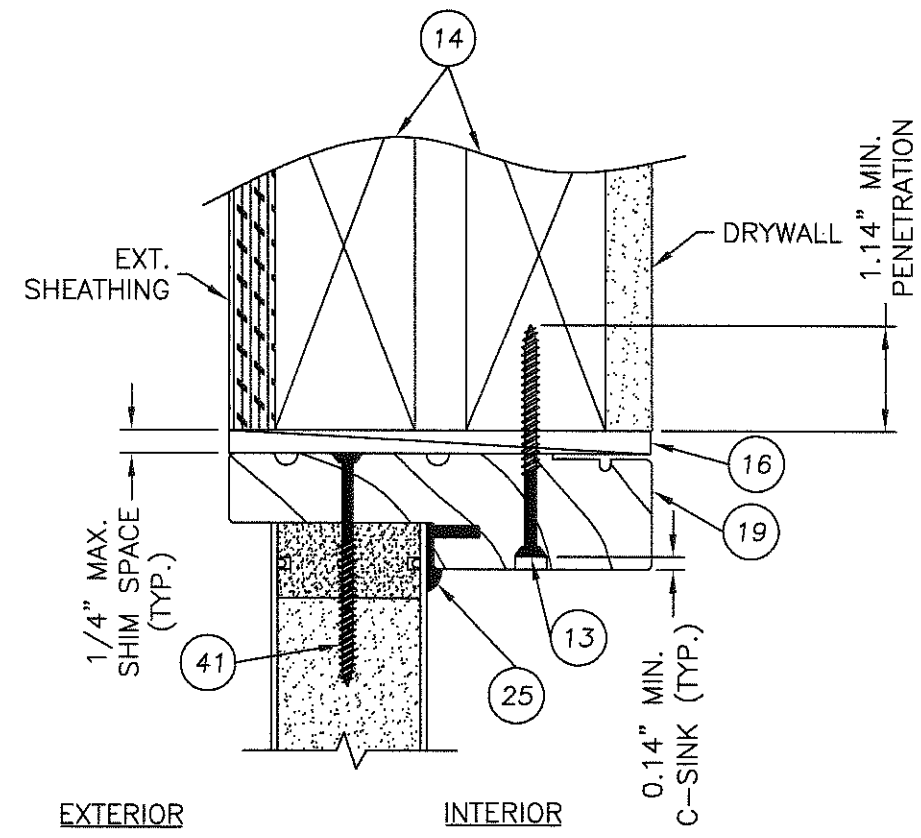

1 VERTICAL CROSS SECTION  
7 ("SMOOTH STAR SERIES" SHOWN)

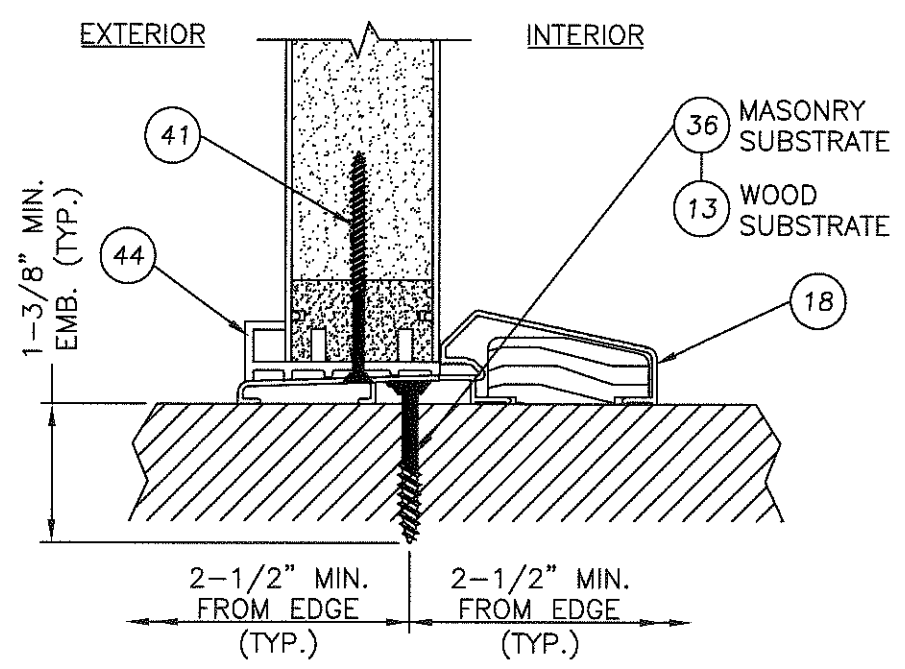

3 VERTICAL CROSS SECTION  
7 OUTSWING CONFIGURATION  
("SMOOTH STAR SERIES" SHOWN)

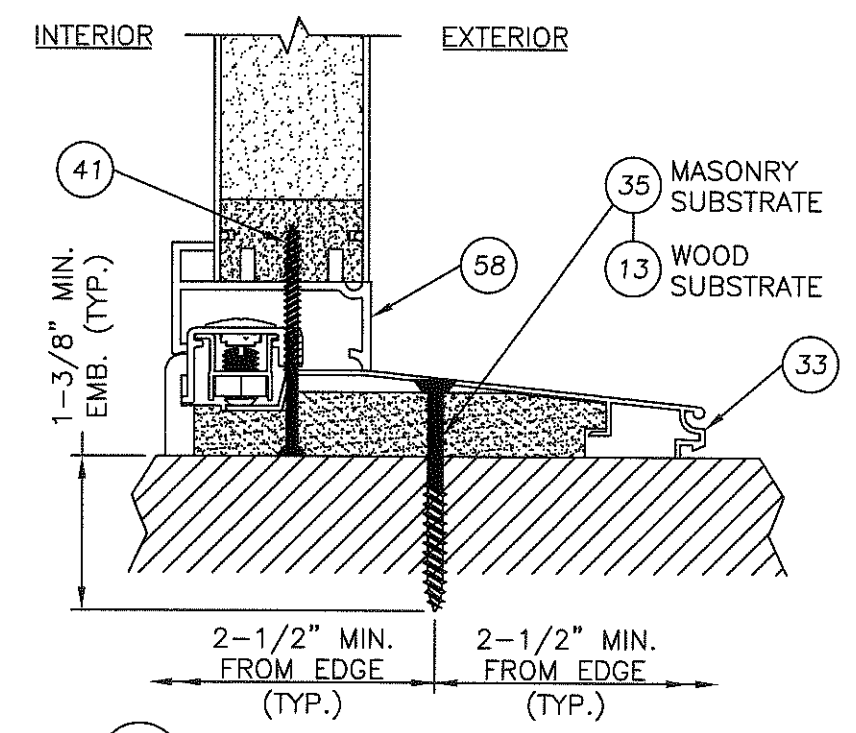

4 VERTICAL CROSS SECTION  
7 INSWING CONFIGURATION  
("SMOOTH STAR SERIES" SHOWN)

Documents Prepared By:		BUILDING CONSULTANTS, INC. P.O. Box 230 Valrico FL 33595 Phone No.: 813.659.9197 Florida Board of Professional Engineers Certificate Of Authorization No. 9813 <i>Wendell W. Pope</i> 7-23-08 Wendell W. Pope, P.E. No. 54158	
PRODUCT:	THERMA-TRU GLAZED FIBERGLASS DOOR W/ SIDELITES IN/OUTSWING "IMPACT"	PART OR ASSEMBLY:	VERTICAL CROSS SECTIONS
NO.	DATE	REV.	LOCK & DEADBOLT MODEL
1	7/9/08		
DATE: 12/15/06		SCALE: N.T.S.	
DWG. BY: AEM		CHK. BY: WWH	
DRAWING NO.: TX-3182		SHEET 7 OF 9	

K:\A - PROJECTS\PROJECT FOLDERS\PROJ 1101 - 1200\PT.1105\D. KWBC DRAWINGS\X-3182\X-3182 REV 1\X-3182-8.DWG, MODEL

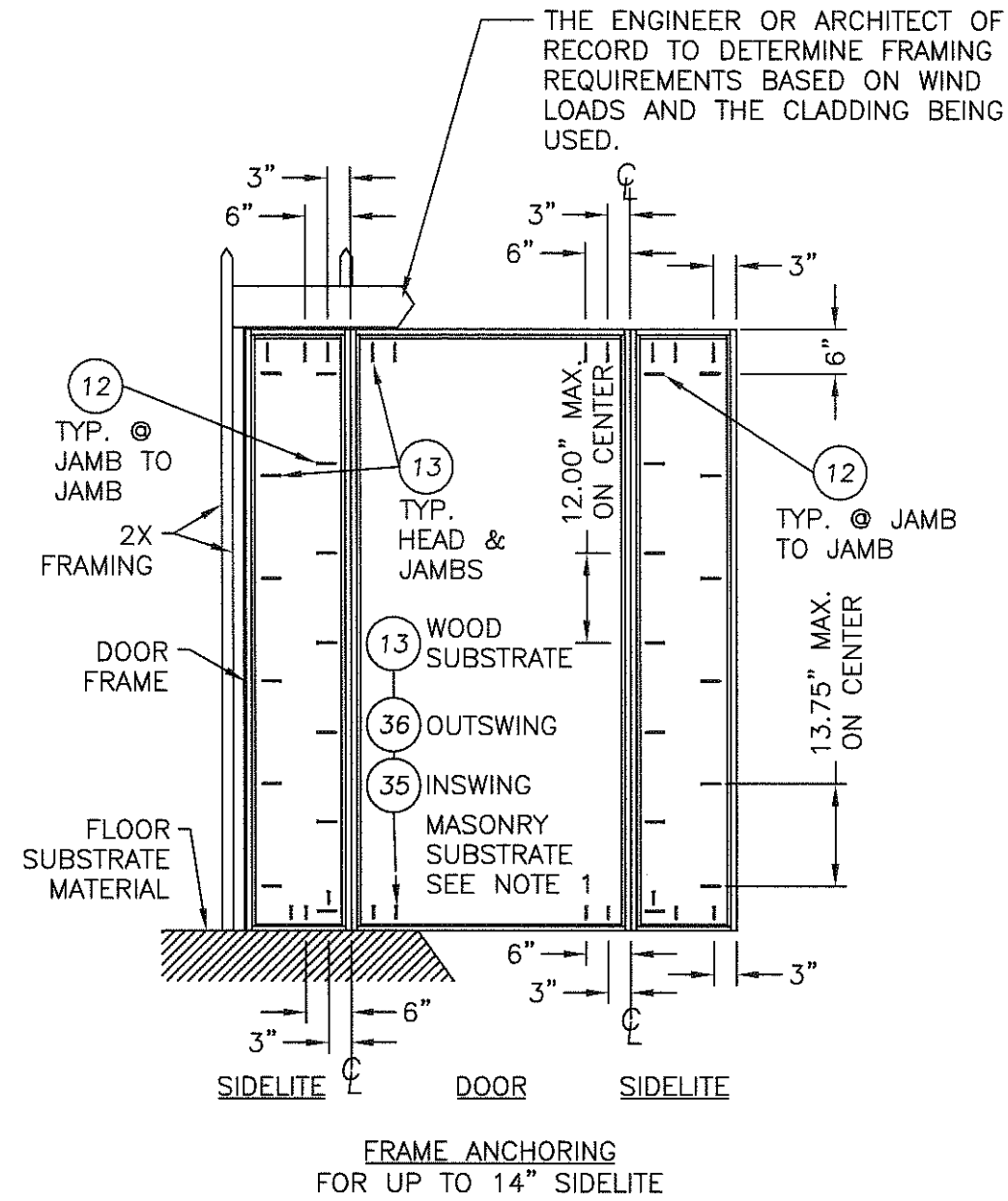
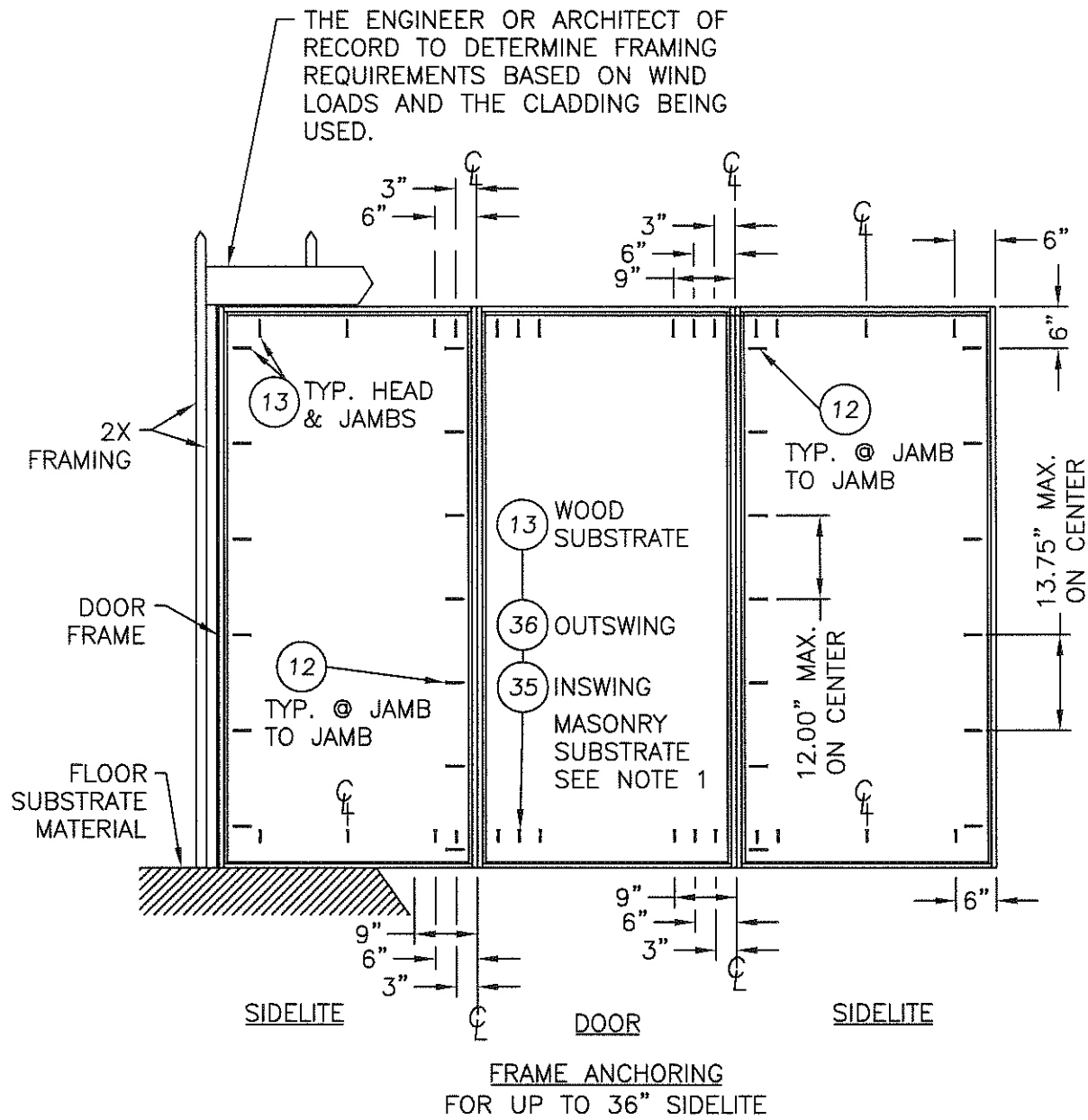

**NOTES:**

1. 1/4" ITW CONCRETE SCREWS ANCHORING FRAME AND/OR SILL REQUIRE A MINIMUM 2-1/2" CLEARANCE TO MASONRY EDGES AND A MINIMUM 3" CLEARANCE TO ADJACENT CONCRETE SCREWS UNLESS OTHERWISE NOTED BY CONCRETE SCREW MANUFACTURER.

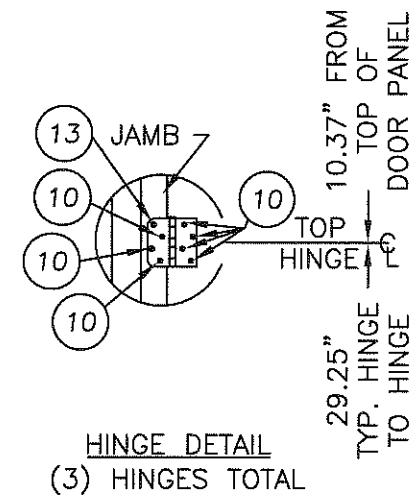
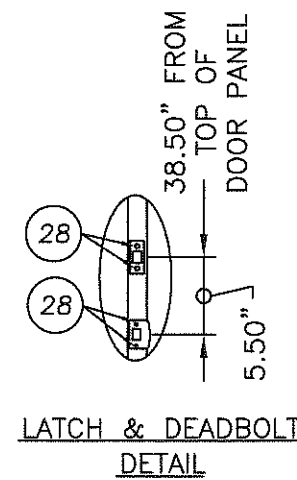

Documents Prepared By: **RW BUILDING CONSULTANTS, INC.**  
P.O. Box 230 Valrico FL 33595  
Phone No.: 813.659.9197  
Florida Board of Professional Engineers  
Certificate of Authorization No. 9813  
Wendell W. Hagedorn, P.E. No. 54158

PRODUCT: THERMA-TRU DOOR W/ GLAZED FIBERGLASS SIDELITES IN/OUTSWING "IMPACT"

PART OR ASSEMBLY: FRAME ANCHORING

NO.	DATE	REV. LOCK & DEADBOLT MODEL	AL	BY
1	7/9/08			

REVISIONS

DATE: 12/15/06  
SCALE: N.T.S.  
DWG. BY: AEM  
CHK. BY: WWH  
DRAWING NO.: TX-3182  
SHEET 8 OF 9

© 2008 R.W. BUILDING CONSULTANTS INC.



K:\A - Projects\Project Folders\Proj 1101 - 1200\pr1105\D. RWBC Drawings\1X-3182\1X-3182 REV 1\1X-3182-9.DWG, Model

Item	DESCRIPTION	Material
1	DOOR SKIN; SMOOTH STAR SERIES (.065" MIN.)	FIBERGLASS
1A	DOOR SKIN; CLASSIC CRAFT SERIES & RUSTIC (.090" MIN.)	FIBERGLASS
1B	DOOR SKIN; FIBER CLASSIC SERIES (.065" MIN.)	FIBERGLASS
2	TOP RAIL DOOR THERMA-TRU (SMOOTH STAR)	COMP.
3	LATCH STILE DOOR THERMA-TRU (SMOOTH STAR)	LVL
4	HINGE STILE DOOR THERMA-TRU (SMOOTH STAR)	WOOD
5	BOTTOM RAIL DOOR THERMA-TRU (SMOOTH STAR)	COMP.
6	POLYURETHANE FOAM	FOAM
7	MEDIUM REACH COMPRESSION WEATHER-STRIP (THERMA-TRU)	FOAM
8	LONG REACH COMPRESSION WEATHER-STRIP (THERMA-TRU)	FOAM
9	4" x 4" HINGE .097" THK. (THERMA-TRU)	STEEL
10	#10 x 3/4" PFH WOOD SCREW (Hinge to Frame)	STEEL
11	#10 x 1-1/2" PPH SHEET METAL SCREW	STEEL
12	#10 x 2" PFH WOOD SCREW	STEEL
13	#10 x 2-1/2" PFH WOOD SCREW	STEEL
14	2X FRAMING	WOOD
15	NOT USED	-
16	MAX. 1/4" SHIM MATERIAL	WOOD
17	LOCK - KWIKSET ULTRAMAX 740	STEEL
18	THRESHOLD OUTSWING (THERMA-TRU)	ALUM./WOOD
19	HEADER JAMB (4.656" x 1.25" THERMA-TRU, PINE)	WOOD
20	SIDE JAMB (4.656" x 1.25" THERMA-TRU) (FJ PINE)	WOOD
21	DEADBOLT - KWIKSET 780 SINGLE CYLINDER	STEEL
22	INTERIOR LITE FRAME	ALUM.
23	EXTERIOR LITE FRAME	ALUM.
24	LOCK BLOCK (SMOOTH STAR)	WOOD
25	SILICONE CAULK	SILICONE
26	CELLULAR GLAZING TAPE	FOAM
27	LATCH STRIKE	STEEL
28	#8 x 2-1/2" PFH WOOD SCREW	STEEL
29	#8 x 3" PFH SCREW	STEEL
30	1" THK. INSUL. LAMINATED GLASS (INTERLAYER BY SOLUTIA) 1/8" TEMP.- AIR - 5/32" ANN. / .090" INTERLAYER / 1/8" ANN.	GLASS
31	NOT USED	-
32	DOOR BOTTOM SWEEP (INSWING)	PVC
33	INSWING THRESHOLD	ALUM./COMP.
34	NOT USED	-
35	1/4" x 2-1/4" ITW TAPCON	STEEL
36	1/4" x 1-3/4" ITW TAPCON	STEEL
37	NOT USED	-
38	NOT USED	-
39	LITE FRAME TRIM	PVC
40	#9 x 3" PFH WOOD SCREW	STEEL
41	#9 x 2-1/2" PFH SCREW	STEEL
42	SIDELITE TOP RAIL (SMOOTH STAR)	COMP.
43	SIDELITE BOTTOM RAIL (SMOOTH STAR)	COMP.
44	OUTSWING SIDELITE SPACER	PVC
45	SIDELITE STILE (SMOOTH STAR)	WOOD
46	TOP RAIL (CLASSIC CRAFT & RUSTIC)	COMP.
47	BOTTOM RAIL (CLASSIC CRAFT & RUSTIC)	COMP.
48	LATCH SIDE STILE (CLASSIC CRAFT & RUSTIC)	LSL / OAK
49	HINGE SIDE STILE (CLASSIC CRAFT & RUSTIC)	LSL / OAK
50	TOP RAIL (FIBER CLASSIC)	COMP.
51	BOTTOM RAIL (FIBER CLASSIC)	COMP.
52	HINGE SIDE STILE (FIBER CLASSIC)	WOOD
53	LOCK BLOCK (FIBER CLASSIC)	WOOD
54	LATCH SIDE STILE (FIBER CLASSIC)	LVL / OAK
55	SIDELITE TOP & BOTTOM RAIL (CLASSIC CRAFT, RUSTIC & FIBER CLASSIC)	COMP.
56	SIDELITE BOTTOM RAIL (CLASSIC CRAFT, RUSTIC & FIBER CLASSIC)	COMP.
57	SIDELITE STILE (CLASSIC CRAFT, RUSTIC & FIBER CLASSIC)	WOOD
58	SIDELITE SPACER INSWING	PVC

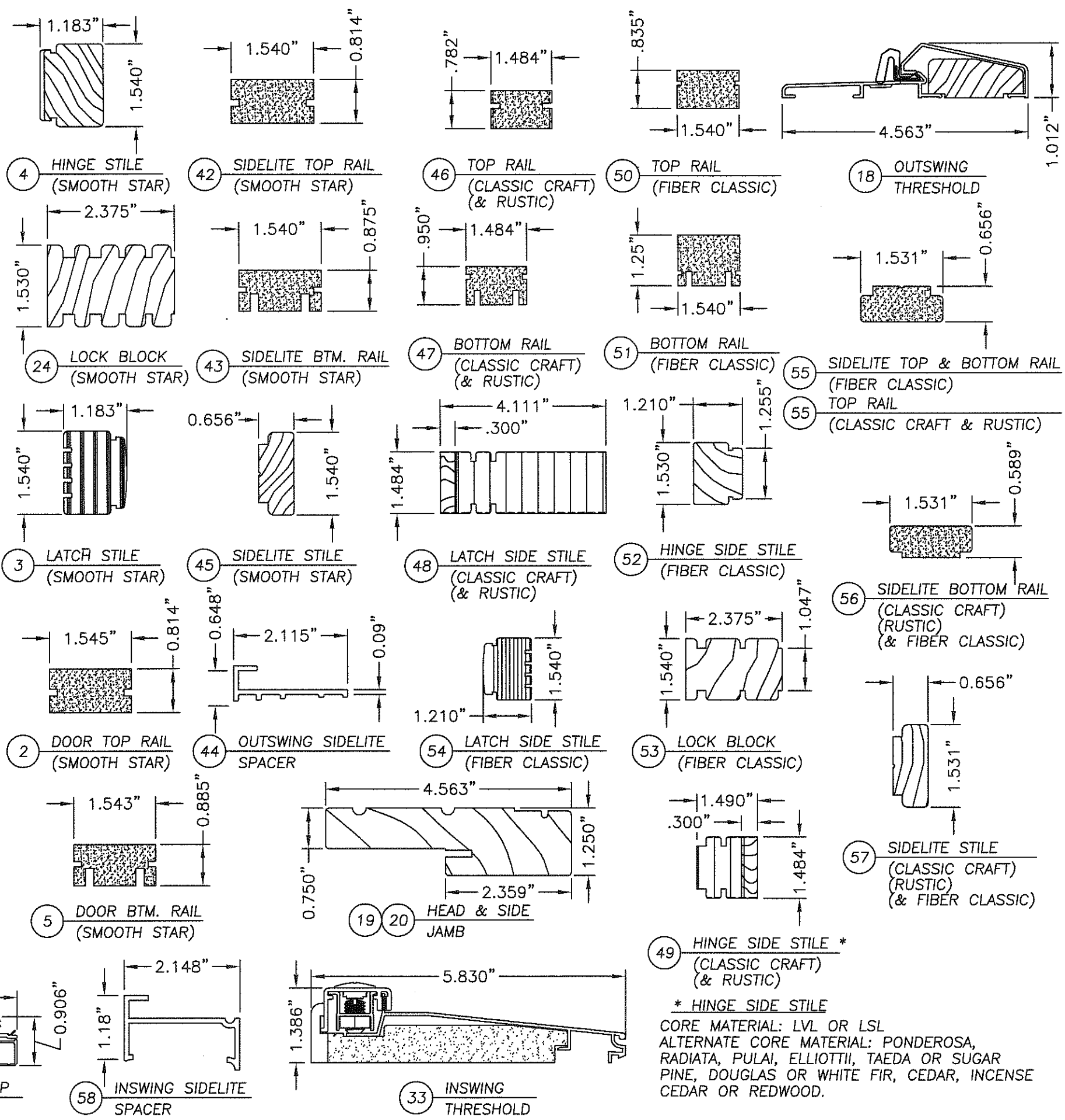

**49** HINGE SIDE STILE \* (CLASSIC CRAFT & RUSTIC)  
 \* HINGE SIDE STILE  
 CORE MATERIAL: LVL OR LSL  
 ALTERNATE CORE MATERIAL: PONDEROSA, RADIATA, PULAI, ELLIOTTII, TAEDA OR SUGAR PINE, DOUGLAS OR WHITE FIR, CEDAR, INCENSE CEDAR OR REDWOOD.

Documents Prepared By: **RW** BUILDING CONSULTANTS, INC.  
 P.O. Box 230 Valrico FL 33595  
 Phone No.: 813.659.9197  
 Florida Board of Professional Engineers  
 Certificate Of Authorization No. 9813  
 Wendell W. Haggerty P.E. No. 54158

PRODUCT: THERMA-TRU GLAZED FIBERGLASS DOOR W/ SIDELITES IN/OUTSWING "IMPACT"  
 PART OR ASSEMBLY: BILL OF MATERIALS & COMPONENTS

NO.	DATE	REV.	LOCK & DEADBOLT MODEL	AL	BY
1	7/9/08				

REVISIONS

DATE: 12/15/06  
 SCALE: N.T.S.  
 DWG. BY: AEM  
 CHK. BY: WWH  
 DRAWING NO.: TX-3182  
 SHEET 9 OF 9

© 2008 R.W. BUILDING CONSULTANTS, INC.