



Kiln Safety Training Program



A powerful industrial rotating kiln used for metal ore roasting.

Goal

The goal of this safety training program is to provide information to ensure the safe and efficient use of electric and gas kilns in commercial and industrial settings.

Objectives

The objectives of this program aim to provide participants with the knowledge and awareness to safely install, ventilate, operate, and maintain electric and gas kilns; identify and mitigate hazards; and implement safety measures.

Overview

Kilns are ovens used for firing, drying, baking, hardening, or burning a substance, particularly clay products, but originally also grain and meal.¹ Modern kilns are used in ceramics to fire clay and porcelain objects, in metallurgy for roasting iron ores, in burning lime and dolomite, and in making Portland

cement. They may be lined with fired brick or constructed entirely of heat-resistant alloys.

There are many [types of kilns](#) used for different purposes, but they fall into four basic categories: wood-fired, coal-fired, electric, or gas kilns. While traditional methods of using wood-fired and coal-fired kilns are still valued for the unique effects they produce on ceramics,² this safety training program focuses solely on the safe use of modern electric and gas kilns.

Before discussing the hazards and safety protocols of electric and gas kilns, individuals who use kilns can benefit from understanding each kiln's components and the differences in their firing and combustion processes.

Electric kiln components

The electric currents that pass through the coils or rods in electric kilns offer precise temperature control. This makes electric

kilns generally easier to operate and maintain than gas kilns. This is one reason why electric kilns are more commonly used in schools, studios, and small-scale production settings. Electric kilns generally include the following components:

- **Heating elements.**
Electric kilns use heating elements made of materials such as heat-resistant wire (Kanthal or Nichrome wire). These elements generate heat when an electric current passes through them.
- **Chamber.**
The chamber is the main part of the kiln where the materials are fired. It is usually lined with a refractory material to withstand high temperatures.
- **Control panel.**
The control panel houses the temperature controls, timers, and other settings for operating the kiln. It allows the user to set and monitor the firing temperature and duration.
- **Ventilation system.**
Electric kilns may have a ventilation system to remove fumes and gases produced during firing. This is particularly important when firing materials that release harmful substances.
- **Safety features.**
Electric kilns are equipped with safety features such as overheat protection and circuit breakers to prevent accidents and ensure safe operation.

Parts of a small electric kiln often used in ceramics studios

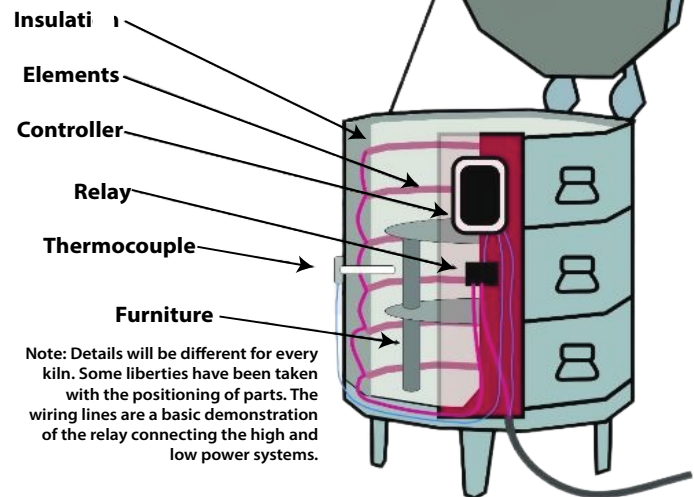

Gas kiln components

Gas kilns rely on the combustion of fuel, usually natural gas or propane, to generate heat. In these kilns, burners release a mixture of fuel and air into the chamber. The fuel-air mixture is ignited, producing a flame that heats the kiln. Gas kilns have greater temperature ranges, which makes them more suitable for a variety of firing techniques and specific effects. They are commonly used in larger-scale production settings by experienced craftsmen. Their components include:

- **Burners.**
Gas kilns use burners to generate heat. The burners are usually located at the base or sides of the kiln and are connected to a gas supply. The type of burner can vary, such as an atmospheric burner or forced-air burner.
- **Chamber.**
Similar to electric kilns, the chamber is where the materials are fired. It is lined with a refractory material to withstand high temperatures.

- **Flue system.**

Gas kilns have a flue system that allows the combustion gases to escape. The flue may include a chimney or a system of ducts to control the flow of gases.

- **Control panel.**

Gas kilns may have a control panel that includes temperature controls, gas flow regulators, and safety features such as flame sensors and gas shut-off valves.

- **Ventilation system.**

Like electric kilns, gas kilns have a ventilation system to remove fumes and gases produced during firing.

- **Gas supply.**

Gas kilns require a fuel source, such as natural gas or propane, which is supplied through gas lines or tanks.

It is important to note that a kiln's components vary slightly depending on the specific design, size, and manufacturer.

Installation

When installing and setting up a kiln it is important to take precautions to prevent fires. Kiln fires can occur due to various factors, including the overheating of the kiln and surrounding structures. Despite mineral insulation, the metal casing of a kiln has the potential to reach temperatures of more than 1,500°F (about 830°C). Therefore, it is crucial to use these tips when installing a kiln:

- Locate the kiln in a separate room or area away from general work areas.
- Place the kiln on a load-bearing floor with ample space between the kiln and the ceiling.

Gas kiln setup and installation

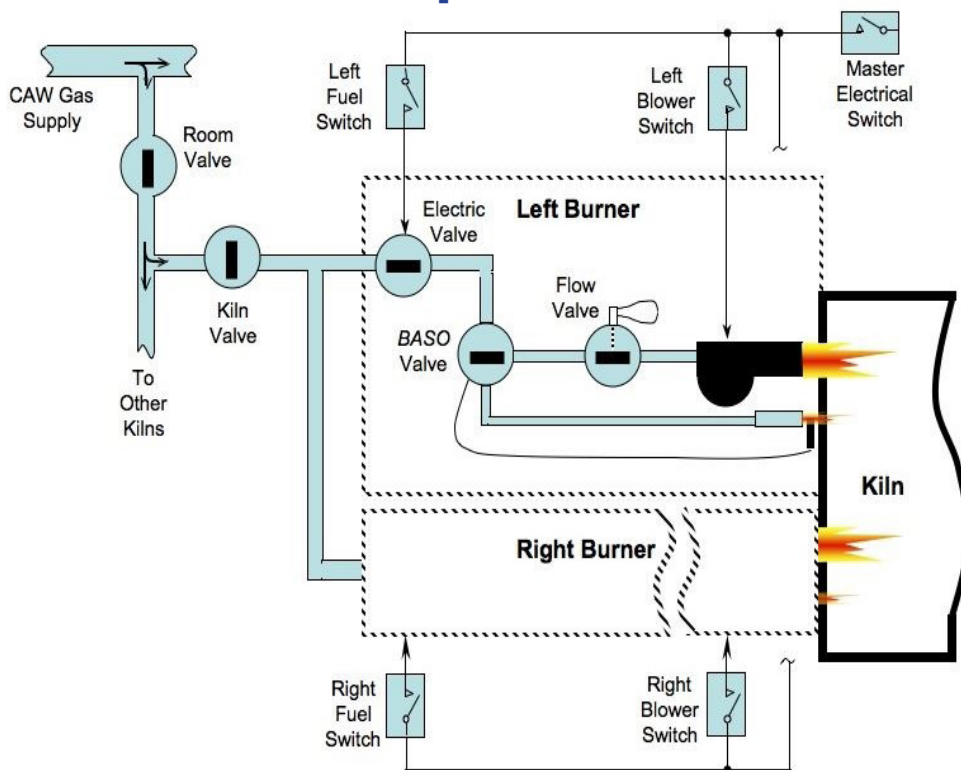

- Ensure that nearby floors, ceilings, and walls are made of non-combustible material.
- Consult a structural specialist for advice if there are any concerns about the strength of the flooring.
- Install heat shields or metal canopy hoods and flues above the kilns. Ensure the canopy extends well over the kiln door.
- Use only a trained professional to install flues.

Cylinder Lime-Burning Kiln for Cement Manufacturing

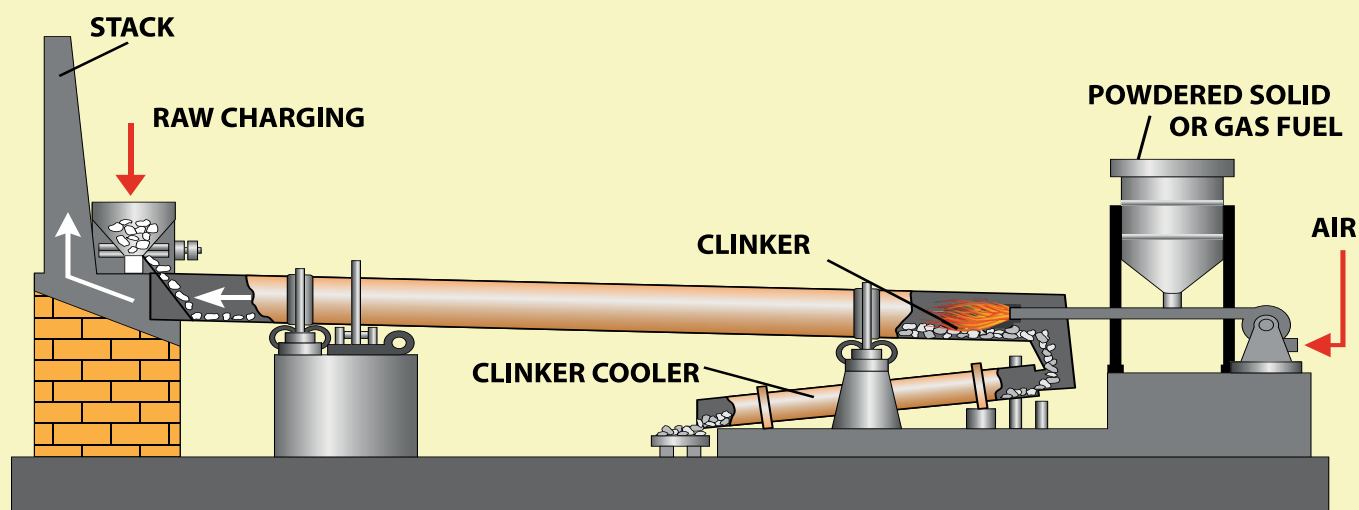

- Use a professional for all gas and electric hookups.
- Leave ample space around the kiln for maintenance, servicing, and free movement of air.
- Follow all fire codes for the installation and operation of kilns.
- Ground all electrical components used in the kiln.

Ventilation

A healthy working environment requires that kilns have proper ventilation so those who use kilns can have fresh air. Depending on whether using an electric or gas kiln, the following protocols can help ensure those working around kilns remain healthy and safe.

Venting electric kilns

Electric kilns can produce harmful fumes or gases during the firing process. Proper ventilation improves air quality, prevents health risks and enhances the firing results.

Ventilation also helps to remove heat and moisture from the kiln room. With a small electric kiln, adequate ventilation can occur through open doors and windows or mechanically using a fan to supply air. However, if the kiln is large or in a smaller room, the room should have a commercial exhaust ventilation system.

Venting gas kilns

Gas kilns produce combustion byproducts, including carbon monoxide and nitrogen dioxide. The firing process may also produce hazardous fumes, such as sulfur oxides, hydrogen fluoride, and metal vapors, depending on the clays, glazes, or other decorative products getting fired. All gas kilns must have a ventilation system that effectively removes these fumes to ensure a safe working environment. Always:

- Vent the fumes directly to the outside.
- Use a professional to install the ventilation system to meet local building and safety codes.

- Regularly inspect and maintain the ventilation system to ensure its proper functioning.

Operation

Only trained operators who know safe working procedures and the proper use of controls and safety devices should use kilns. These guidelines can help ensure that electric and gas kilns are used safely:

Safe operations of electric kilns

- **Read and understand the manufacturer's instructions.**
Familiarize yourself with the manufacturer's instructions and guidelines for operating the electric kiln. Understand the kiln's features, controls, and safety mechanisms before use.
- **Follow electrical safety guidelines.**
Ensure that the kiln is properly grounded and connected to a properly rated and protected electrical outlet. Avoid using extension cords and plug the kiln directly into the outlet. If you notice any electrical issues or abnormalities, such as sparks, unusual noises, or overheating, immediately disconnect the kiln and seek professional assistance.
- **Use proper loading and unloading procedures.**
Follow proper loading and unloading procedures to prevent injuries and damage to the kiln. Use appropriate protective

equipment, such as heat-resistant gloves, when handling hot materials or kiln furniture.

- **Adhere to the manufacturer's firing schedule.**
Follow recommended firing schedules provided by the manufacturer. Avoid rapid temperature changes or excessive temperatures that may cause thermal shock to the kiln or materials.
- **Monitor kiln operations.**
Regularly monitor the kiln during operations, especially during the initial stages of firing, to detect any issues or abnormalities. Always keep a safe distance from the kiln while it is in operation. Avoid touching hot surfaces.

Safe operations of gas kilns

- **Ensure fumes are vented to the outside.**
Use proper ventilation in the kiln room to prevent the buildup of potentially





harmful gases. Always maintain a dedicated exhaust system that vents fumes directly to the outside.

- **Follow the manufacturer's instructions for lighting and extinguishing the gas kiln's burners.**

The flame source, whether a blow torch, gas match, or fireplace match, needs to be long enough to keep the operator well away from the burner openings. Always keep the kiln door or lid open when lighting.

- **Regularly inspect gas lines, valves, and connections for leaks and damage.**

If you suspect a gas leak, immediately shut off the gas supply, ventilate the area, and contact a licensed professional for repairs. If gas piping is modified, always pressure test it and soap test it. Never check for leaks with an open flame.

- **Follow recommended firing and cooling procedures specified by the manufacturer.**

Avoid opening the kiln door during firing, as it can disrupt the combustion process and cause potential hazards. Allow the kiln to cool down completely before unloading or making any adjustments.

- **Keep fire extinguishers and other fire safety equipment readily available in the kiln room.**

Familiarize yourself with the location and operation of fire extinguishers and emergency shut-off controls.

- **Obtain proper safety training and education from experienced potters or professionals.**

Stay updated with safety practices, regulations, and guidelines related to gas kilns.

Maintenance

Proper maintenance of electric and gas kilns can prevent accidents and exposure to toxic fumes.

Maintenance of electric kilns

- **Clean regularly.**

Clean the interior of the kiln regularly to remove any debris, dust, or glaze buildup. Use a soft brush or vacuum

cleaner designed for kiln use. Also, clean the kiln shelves and furniture to prevent material contamination and ensure even heat distribution.

- **Inspect and replace elements as needed.**

Check the kiln elements regularly for signs of wear, damage, or uneven heating. Damaged or worn-out elements should be replaced promptly to maintain consistent firing results. Always follow the manufacturer's instructions for element replacement. Consult a professional if needed.

- **Check electrical connections.**

Inspect the electrical connections, wiring, and controls periodically to ensure they are secure and in good condition. Look for any signs of loose connections, frayed wires, or damage. If any issues are found, contact a qualified electrician for repairs.

- **Monitor and calibrate the temperature.**

Regularly monitor and calibrate the kiln's temperature using an accurate and reliable thermocouple or pyrometer. Always follow the manufacturer's instructions for calibration procedures and frequency.

- **Follow the manufacturer's recommended preventative maintenance schedule.**

This may include tasks such as lubricating moving parts, checking and replacing kiln furniture, and inspecting safety features.

Maintenance of gas kilns

- **Clean and inspect burners.**

Clean the burners periodically to



remove any debris or blockages that may affect their performance. Also, inspect the burners for signs of wear, corrosion, or damage. Replace any faulty burners promptly.

- **Check the gas supply and connections.**

Regularly check the gas supply and connections for leaks, loose fittings, or damaged lines. Ensure that the gas pressure is within the recommended range specified by the manufacturer. If you suspect a gas leak, shut off the gas supply immediately and contact a licensed professional for repairs.

- **Monitor and calibrate the temperature.**

Similar to electric kilns, it is important to monitor and calibrate the temperature

of gas kilns using a reliable thermocouple or pyrometer. Always follow the manufacturer's instructions for calibration procedures and frequency.

- **Maintain the ventilation system for proper fume extraction and air circulation.**

Ensure that the exhaust system is functioning effectively.

Remember to clean or replace filters as needed.

- **Perform routine safety inspections.** Periodically inspect the kiln's safety features, such as flame sensors, pilot lights, and safety shut-off valves. Ensure that emergency shut-off controls are easily accessible and in proper working condition.

Hazards

Before starting work on a kiln, it is important that employees know and can identify the following potential hazards and steps to prevent these risks.

Hazards for electric kilns

- **Electrical hazards.** Electric kilns require a significant amount of electricity to operate. Faulty wiring, overloaded circuits, or improper



A close-up view through the inspection hole of a rotary kiln used for clinker production in a cement plant.

grounding can lead to electrical hazards such as electric shock or electrical fires. To mitigate these risks:

- o Follow all electrical specifications, including correct voltage, wire size, and circuit breaker.
 - o Ensure all connections are tight.
 - o Avoid using aluminum wire.
 - o Use a properly grounded receptacle.
 - o Use a qualified electrician for any electrical service or repairs.
- **Overheating.** If the temperature controls or safety features of an electric kiln malfunction, it can lead to overheating. This can cause damage to the kiln or even start a fire.
 - **Burn injuries.** Like gas kilns, electric kilns also reach high temperatures and can cause burn injuries if not handled with caution.
 - **Fumes and gases.** Every firing, even in electric kilns, produces fumes and gases during firing, so proper ventilation is necessary to remove potentially harmful substances from the kiln chamber.

Hazards for gas kilns

- **Gas leaks.**
Gas kilns require the use of natural gas or propane, which can leak if the connections or valves are not properly maintained. Gas leaks can lead to fires or explosions.
- **Carbon monoxide poisoning.**
Incomplete combustion in gas kilns can produce carbon monoxide gas, which is colorless, odorless, and highly toxic. If the kiln is not properly ventilated, carbon monoxide can accumulate and pose a serious health risk.
- **Fire hazards.**
Gas kilns involve open flames, which can result in fire hazards if not handled properly. Any flammable materials nearby should be kept at a safe distance. The best way to extinguish a gas fire is to:

- o **Turn off the gas.**

Ensure everyone in the area knows where the gas valve is and how to turn it off.

- o **Keep fire extinguishers nearby.**

Make fire blankets, sand pails, and appropriate extinguishers available.

Make sure kiln operators know how to use them.

- **Burn injuries.**

The high temperatures in gas kilns can cause severe burn injuries if proper precautions are not taken. Care should be taken when loading and unloading the kiln, as well as when handling hot objects.

In addition to these kiln-specific hazards, the following risks apply to both electric and gas kilns:

Manual handling

Depending on the nature of the ware being fired, loading and unloading the kiln may present a hazard. Trained operators will need to consider the loads being handled during these operations as well as the amount of twisting and turning that has to be done. Where possible, trolleys or other devices should be used to transport wares around the premises and to lift heavy loads. All employees



An industrial kiln used in iron manufacturing.

involved in the manual handling of heavy articles should receive adequate training to prevent injuries.

Refractory fiber linings

Refractory fiber linings are a common insulation material used on kilns. These linings resist high temperatures and offer excellent thermal insulation. However, when disturbed or deteriorated, these fibers can release small airborne particles that can cause respiratory irritation, coughing, and in rare cases, lung diseases like fibrosis.

To minimize refractory fiber hazards:

- Regularly inspect the refractory lining.
- Wear personal protective equipment (PPE) such as gloves, goggles, and respiratory protection when handling or working near refractory fibers.
- Promptly repair or replace any damaged or deteriorated sections.
- Follow the manufacturer's guidelines for safe handling, maintenance, and disposal of refractory fiber materials.
- Seek guidance from the manufacturer or a professional on proper repair or replacement procedures when needed.

By being proactive in inspecting and maintaining refractory fiber linings, you can reduce the risk of fiber release and ensure a safer kiln operation for both gas and electric kilns.

Inhalation of glazing and clay materials during firing

Many glaze and clay materials are hazardous. The inhalation of these materials, especially silica, can damage your lungs. All clay contains some free crystalline silica that can hang in the



air for hours. It can scar your lung tissue and cause irreversible loss of breathing capacity.

To avoid this hazard:

- Wear a well-fitting high-efficiency particulate air (HEPA) filter mask.
- Clean the work area before clay scraps have a chance to dry. Never sweep dry clay.
- Clean areas around the kiln and clay work areas with a wet mop, wet vacuum, or a vacuum equipped with a HEPA filter.
- Provide good fresh air exchange in your work area.
- Wear plastic or vinyl-type aprons rather than porous cloth-style aprons.
- Avoid the use of asbestos-contaminated talc in low-fire white and raku clay bodies.
- Avoid the use of glazes with barium carbonate, sodium borates, and lead compounds.
- Call your manufacturer to see if there are any ingredients of concern to you in the commercial glazes, slips, or stains you may fire.

- Read the OSHA Safety Data Sheets for detailed information about the hazardous materials that you may fire.
- Firing should only be done by those with firing experience and a thorough understanding of all kiln functions and safety controls.

Heat and infrared radiation from kiln firings

The intense heat and infrared radiation from all kiln firings can damage your eyes. Wear welder's goggles when looking in the kiln spy holes.

Other safety measures

- **Use personal protective equipment (PPE).**
Below is the recommended safety gear to wear when using a kiln:
 - o **Wear fire-rated kiln mitts or gloves** when handling any part of the kiln while it is hot, other than the control panel.
 - o **Wear dark, infrared glasses** from a safety supply house when looking into kiln spy holes to protect your eyes from radiant heat.
 - o **Wear protective clothing** and keep it well away from any kiln opening or hot kiln surface.
- **Use good housekeeping.**
Good housekeeping around kilns is essential. Never store combustible

materials or allow them to accumulate around the kiln.

- **Keep liquids away from kilns.**
If there is any water damage to the circuitry, run a full diagnostic check once it dries out.
- **Watch for fires.**
If flames are evident anywhere near a gas kiln except in the chimney or damper flues, spy holes, burner ports, or passive dampers, shut off the main gas valve, leave the building, and inform the proper authorities. Ensure all gas kiln users know where the gas valve is and how to turn it off. Fire blankets and sand pails should also be available.

Review Questions

1. Why should a kiln be located in a separate room?
2. Ventilation is critical to working around kilns. True or False.
3. What type of gloves should be worn when working with a kiln?



Answers to Review Questions: 1. Reduce heat; 2. True; 3. Fire-resistant kiln gloves.

References

¹Britannica, T. Editors of Encyclopaedia (2024, January 20). kiln. Encyclopedia Britannica. <https://www.britannica.com/technology/kiln-oven>. Accessed Feb. 5, 2024.

²SD Industries, "Everything You Need to Know About Controlling Your Kiln," <https://www.kilncontrol.com/blog/types-of-kilns/>. Accessed Feb. 6, 2024.



www.txsafetyatwork.com

1-800-252-7031, Option 2

*The Texas Department of Insurance,
Division of Workers' Compensation (DWC)-Workplace Safety
P.O. Box 12050
Austin, TX 78711-2050*

Disclaimer: Unless otherwise noted, this document was produced by the Texas Department of Insurance, Division of Workers' Compensation using information from staff subject specialists, government entities, or other authoritative sources. Information contained in this fact sheet is considered accurate at the time of publication. For more free publications and other occupational safety and health resources, visit www.txsafetyatwork.com, call 800-252-7031, option 2, or email resourcecenter@tdi.texas.gov.